

## 7. AT Shift Lock Control Module

S501237

### A: REMOVAL

S501237A18

- 1) Disconnect battery ground cable.

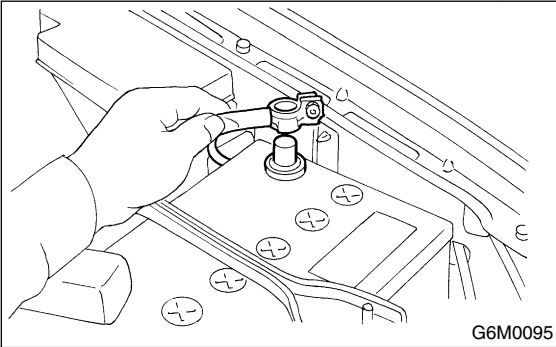

- 2) Remove the lower cover.

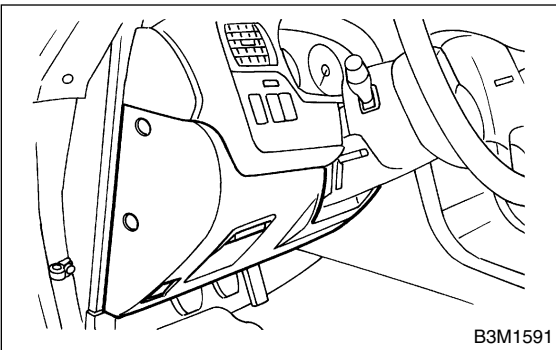

- 3) Remove knee bolster.
- 4) Disconnect connector from AT shift lock control module.

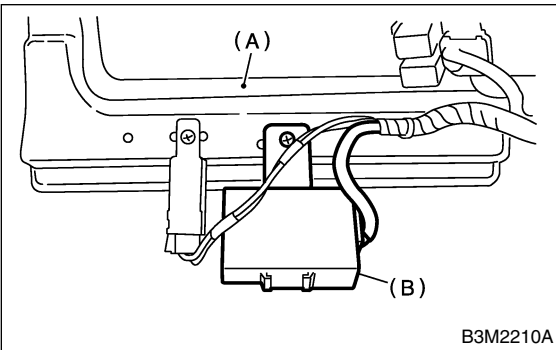

- (A) Knee bolster  
(B) AT shift lock control module

- 5) Remove the AT shift lock control module from knee bolster.

### B: INSTALLATION

S501237A11

Install in the reverse order of removal.