

3. Manual Transmission Assembly

S503224

A: REMOVAL

S503224A18

- 1) Set vehicle on a lift.
- 2) Open front hood fully, and support with stay.
- 3) Disconnect battery ground cable.
- 4) Move gear shift lever to "N", and release the parking brake.
- 5) Remove air intake duct and cleaner case. <Ref. to IN-7, REMOVAL, Air Intake Duct.> and <Ref. to IN-6, REMOVAL, Air Cleaner Case.>
- 6) Remove air cleaner case stay.

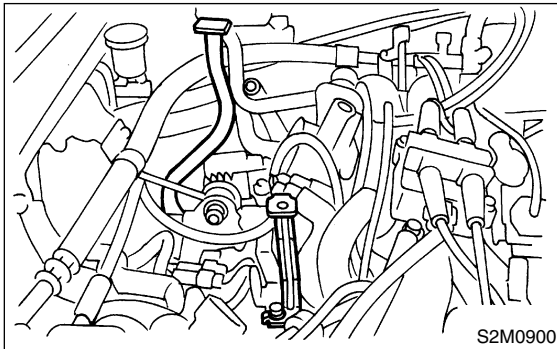

- 7) Disconnect the following connectors.
 - (1) Neutral position switch connector
 - (2) Back-up light switch connector

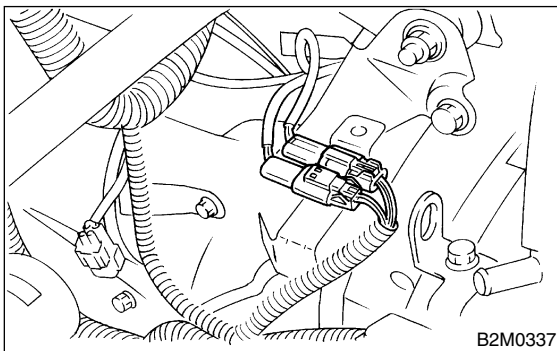

- (3) Vehicle speed sensor

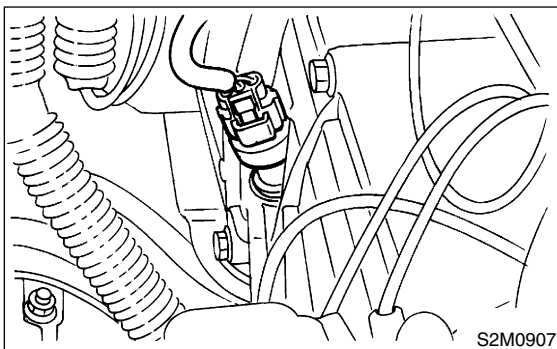

- (4) Transmission ground cable.
- 8) Remove starter. <Ref. to SC-7, REMOVAL, Starter.>

- 9) Remove operating cylinder from transmission.

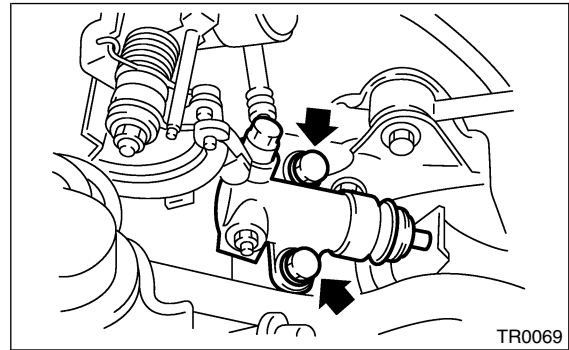

- 10) Remove pitching stopper.

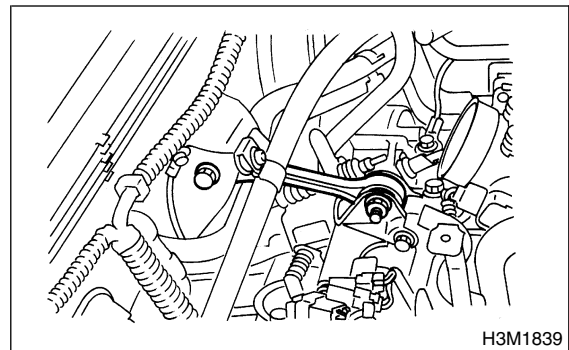

- 11) Set ST.

NOTE:

Part No. 41099AA010 is also available.

ST 41099AA020 ENGINE SUPPORT ASSY

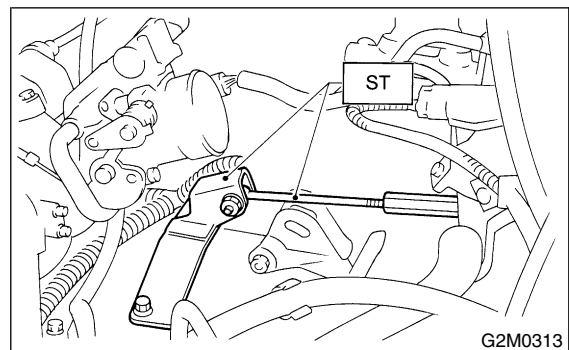

- 12) Remove bolt which holds right upper side of transmission to engine.

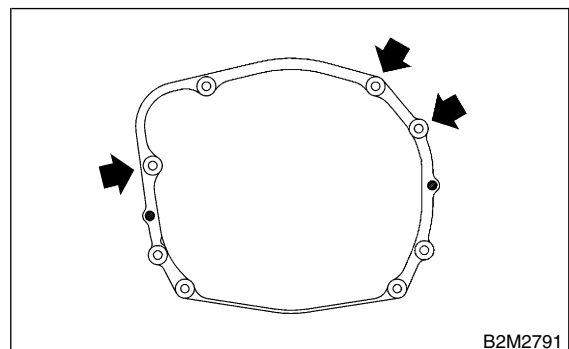

MANUAL TRANSMISSION ASSEMBLY

Manual Transmission and Differential

- 13) Remove front and center exhaust pipes. <Ref. to EX-5, REMOVAL, Front Exhaust Pipe.>
- 14) Remove rear exhaust pipe and muffler. <Ref. to EX-9, REMOVAL, Rear Exhaust Pipe.> and <Ref. to EX-10, REMOVAL, Muffler.>
- 15) Remove heat shield cover.
- 16) Remove hanger bracket from right side of transmission.

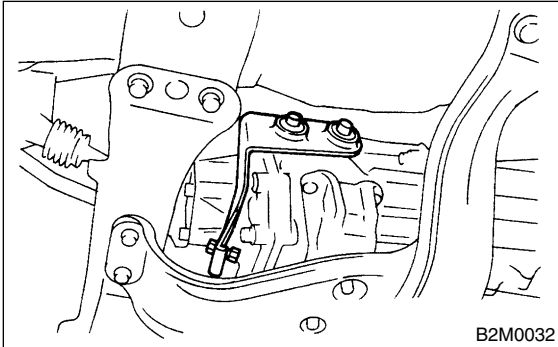

- 17) Remove propeller shaft. <Ref. to DS-13, REMOVAL, Propeller Shaft.>
- 18) Remove gear shift rod and stay from transmission.

- (1) Disconnect stay from transmission.
- (2) Disconnect rod from transmission.

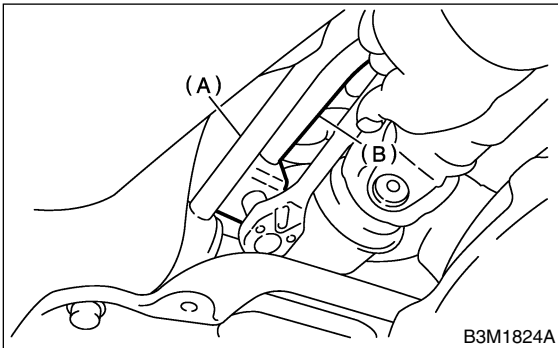

- (A) Stay
(B) Rod

- 19) Disconnect stabilizer link from transverse link.
- 20) Remove bolt securing ball joint of transverse link to housing.

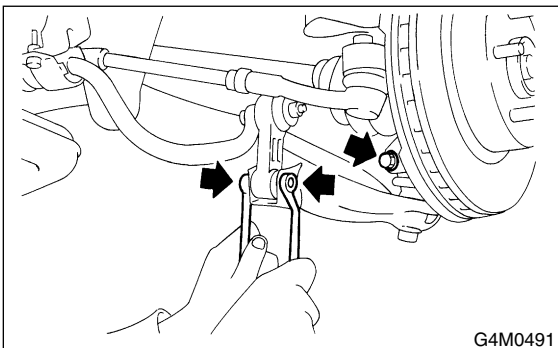

- 21) Remove spring pins and separate front drive shafts from each side of the transmission.

NOTE:

Do not reuse spring pin. Prepare a new spring pin.

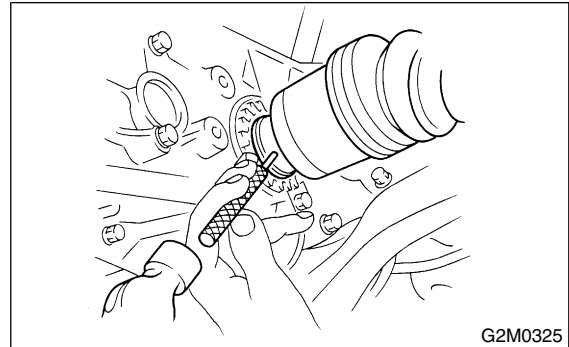

- 22) Remove nuts which hold lower side of transmission to engine.

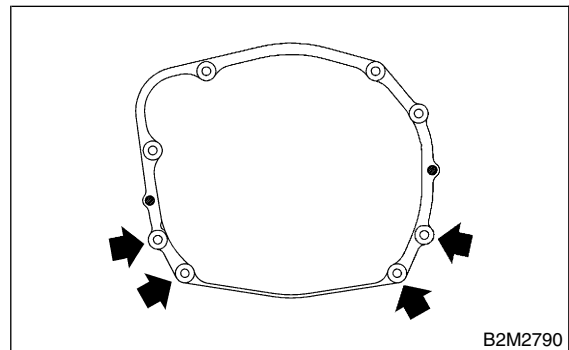

- 23) Place transmission jack under transmission.

CAUTION:

- Always support transmission case with a transmission jack.
- Fix transmission with a band etc.

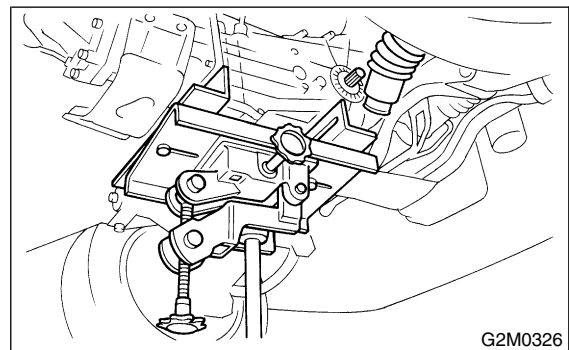

24) Remove transmission rear crossmember from vehicle.

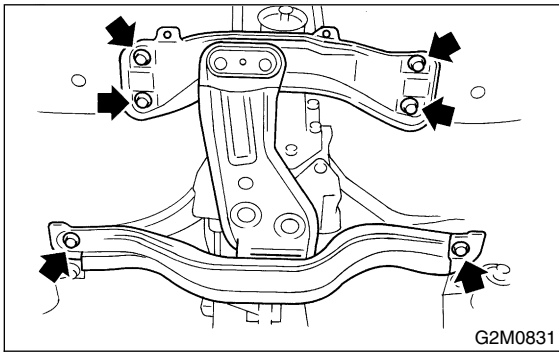

25) Move transmission jack toward rear until main shaft is withdrawn from clutch cover and transmission.

26) Separate transmission assembly and rear cushion rubber.

B: INSTALLATION

S503224A11

1) Install rear cushion rubber to transmission assembly.

Tightening torque:

35 N·m (3.6 kgf-m, 26 ft-lb)

2) Install transmission onto engine.

(1) Gradually raise transmission with transmission jack.

(2) Engage them at splines.

NOTE:

Be careful not to strike main shaft against clutch cover.

3) Install transmission rear crossmember.

Tightening torque:

T1: 75 N·m (7.6 kgf-m, 55 ft-lb)

T2: 140 N·m (14.3 kgf-m, 103 ft-lb)

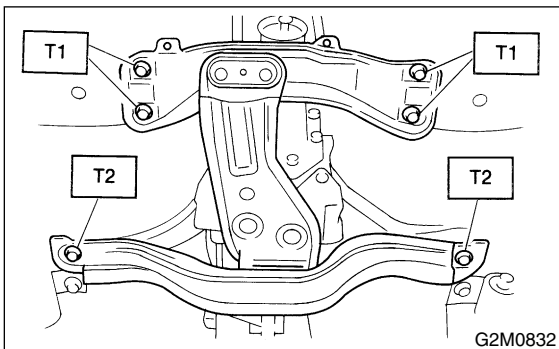

4) Take off transmission jack.

5) Tighten nuts which hold lower side of transmission to engine.

Tightening torque:

50 N·m (5.1 kgf-m, 36.9 ft-lb)

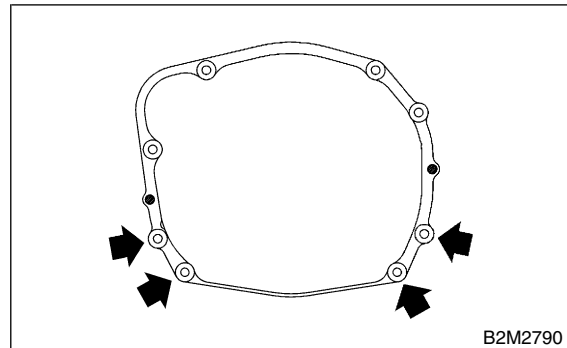

6) Connect engine and transmission.

(1) Install starter.

<Ref. to SC-7, INSTALLATION, Starter.>

(2) Tighten bolt which holds right upper side of transmission to engine.

Tightening torque:

50 N·m (5.1 kgf-m, 36.9 ft-lb)

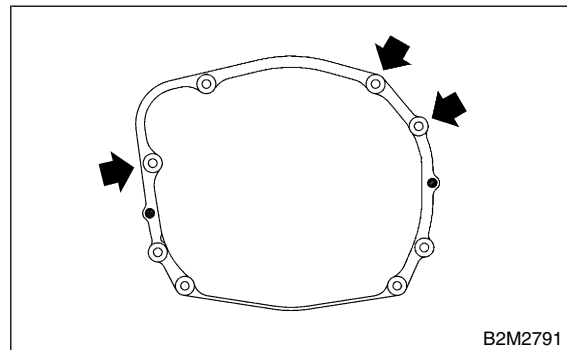

7) Remove ST.

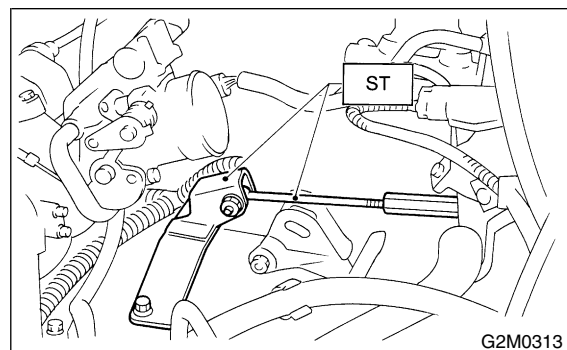

MANUAL TRANSMISSION ASSEMBLY

Manual Transmission and Differential

8) Install pitching stopper.

Tightening torque:

T1: 50 N·m (5.1 kgf-m, 37 ft-lb)

T2: 58 N·m (5.9 kgf-m, 43 ft-lb)

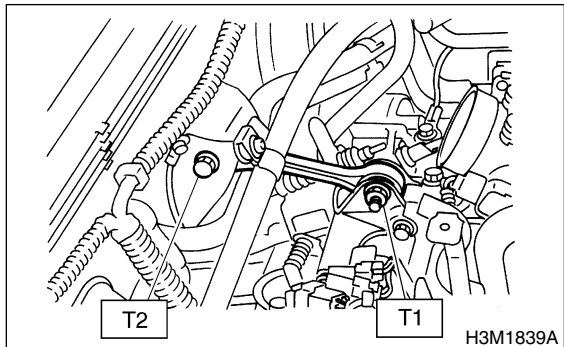

9) Lift-up the vehicle.

10) Install front drive shaft into transmission.

11) Drive new spring pin into chamfered hole of drive shaft.

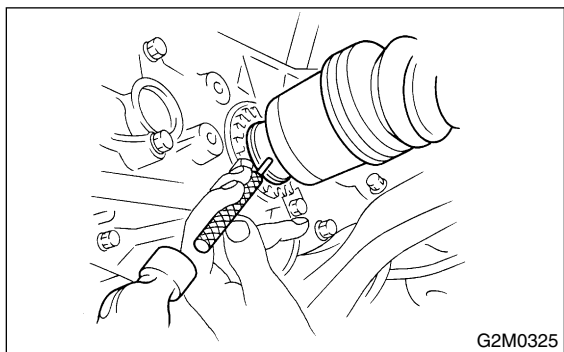

12) Install ball joints of lower arm into knuckle arm of housing, and tighten installing bolts.

Tightening torque:

49 N·m (5.0 kgf-m, 36 ft-lb)

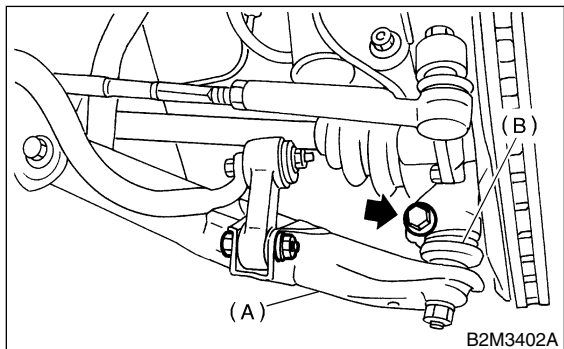

- (A) Transverse link
- (B) Ball joint

13) Install stabilizer link from transverse link.

Tightening torque:

30 N·m (3.1 kgf-m, 22.1 ft-lb)

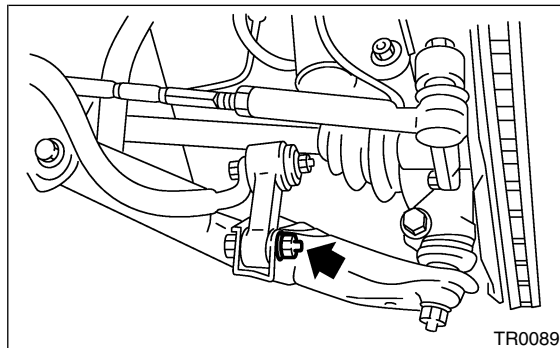

14) Connect rod to the joint.

Tightening torque:

18 N·m (1.8 kgf-m, 13.0 ft-lb)

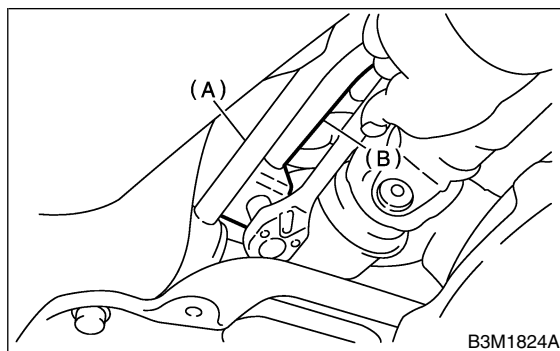

- (A) Joint
- (B) Rod

15) Connect stay to transmission bracket.

Tightening torque:

18 N·m (1.8 kgf-m, 13.0 ft-lb)

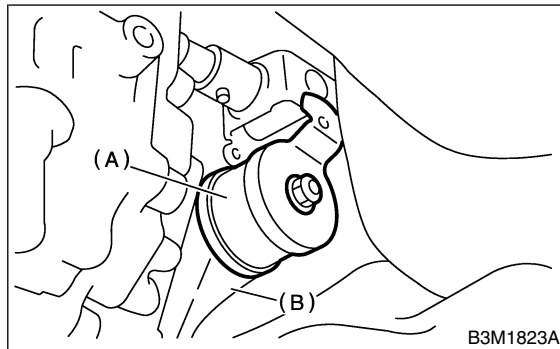

- (A) Stay
- (B) Transmission bracket

16) Install propeller shaft. <Ref. to DS-14, INSTALLATION, Propeller Shaft.>

17) Install heat shield cover.

- 18) Install hanger bracket on right side of transmission.

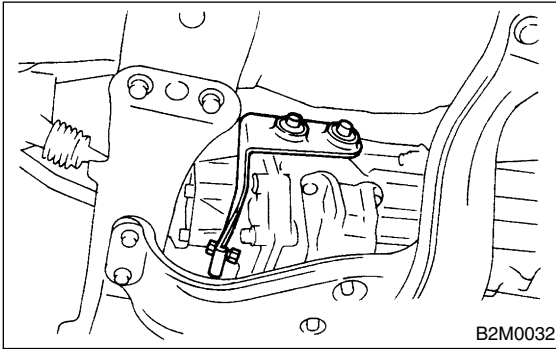

- 19) Install rear exhaust pipe and muffler.
<Ref. to EX-10, INSTALLATION, Muffler.> and
<Ref. to EX-9, INSTALLATION, Rear Exhaust Pipe.>
20) Install front exhaust pipe and center exhaust pipe.
<Ref. to EX-6, INSTALLATION, Front Exhaust Pipe.>
21) Install under cover.
22) Install operating cylinder.

Tightening torque:

37 N·m (3.8 kgf-m, 27.5 ft-lb)

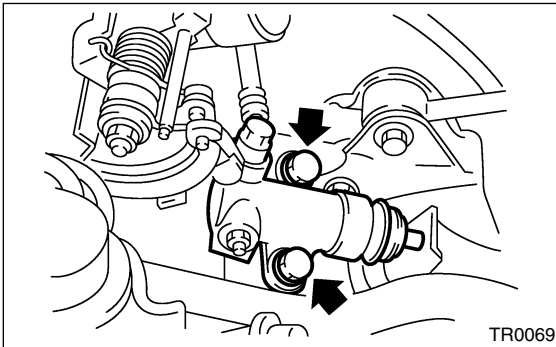

- 23) Connect the following connectors.
(1) Transmission ground terminal

Tightening torque:

13 N·m (1.3 kgf-m, 9.4 ft-lb)

- (2) Vehicle speed sensor connector
(3) Neutral position switch connector
(4) Back-up light switch connector
24) Install air cleaner case stay.

Tightening torque:

16 N·m (1.6 kgf-m, 11.6 ft-lb)

- 25) Install air cleaner case and intake duct. <Ref. to IN-6, INSTALLATION, Air Cleaner Case.> and <Ref. to IN-7, INSTALLATION, Air Intake Duct.>
26) Connect battery ground cable.
27) Pour gear oil and check the oil level. <Ref. to MT-26, Transmission Gear Oil.>
28) Take off vehicle from lift arms.