

9. Transfer Case and Extension Case Assembly S503561

A: REMOVAL S503561A18

- 1) Remove the manual transmission assembly from vehicle. <Ref. to MT-27, REMOVAL, Manual Transmission Assembly.>
- 2) Remove back-up light switch and neutral position switch. <Ref. to MT-35, REMOVAL, Switches and Harness.>
- 3) Remove transfer case with extension case assembly.

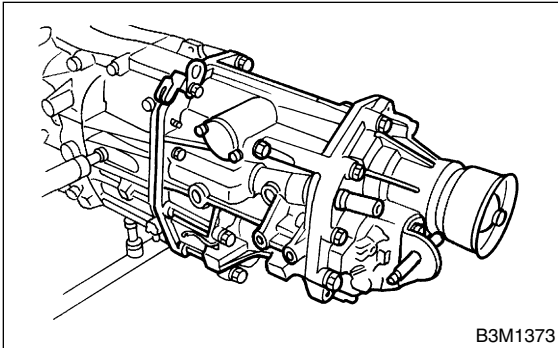

- 4) Remove shifter arm.
- 5) Remove extension case assembly.

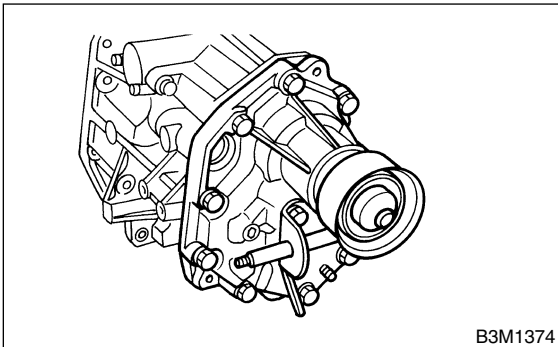

B: INSTALLATION S503561A11

- 1) Install center differential and transfer driven gear into transfer case.

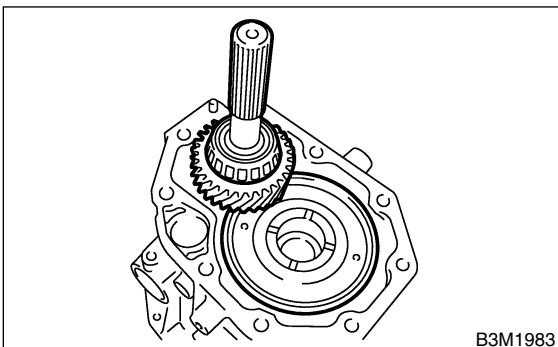

- 2) Remove bearing cone from the extension case assembly, and install to taper roller bearing of the transfer driven gear.

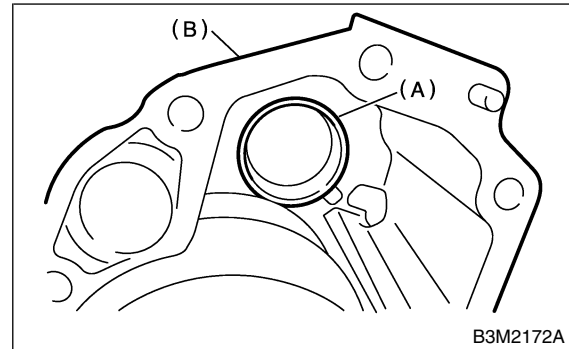

- (A) Bearing cone (Extension case)
 (B) Extension case

- 3) While pressing the bearing cone horizontally, turn the driven shaft ten rotations.
- 4) Measure height "W" between transfer case and taper roller bearing on the transfer driven gear.

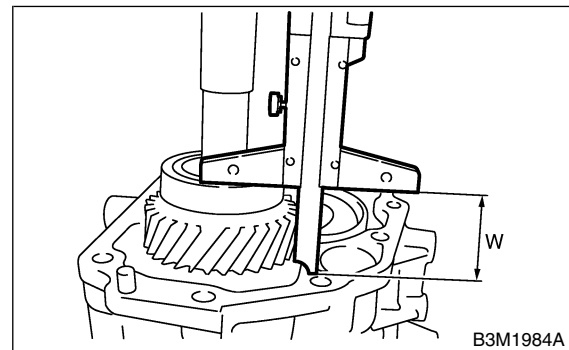

- 5) Measure depth "X".

NOTE:

Measure with bearing cone and thrust washer removed.

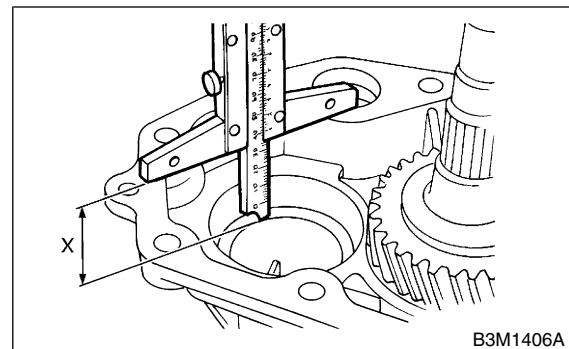

- 6) Calculate space "t" using the following equation: $t = X - W + 0.2$ to 0.3 mm (0.008 to 0.012 in)
- 7) Select nearest washer in the following table:

Standard clearance between thrust washer and taper roller bearing:
0.2 — 0.3 mm T (0.008 — 0.012 in T)

TRANSFER CASE AND EXTENSION CASE ASSEMBLY

Manual Transmission and Differential

NOTE:
T: Tight

Thrust washer (50 × 61 × t)	
Part No.	Thickness mm (in)
803050060	0.50 (0.0197)
803050061	0.55 (0.0217)
803050062	0.60 (0.0236)
803050063	0.65 (0.0256)
803050064	0.70 (0.0276)
803050065	0.75 (0.0295)
803050066	0.80 (0.0315)
803050067	0.85 (0.0335)
803050068	0.90 (0.0354)
803050069	0.95 (0.0374)
803050070	1.00 (0.0394)
803050071	1.05 (0.0413)
803050072	1.10 (0.0433)
803050073	1.15 (0.0453)
803050074	1.20 (0.0472)
803050075	1.25 (0.0492)
803050076	1.30 (0.0512)
803050077	1.35 (0.0531)
803050078	1.40 (0.0551)
803050079	1.45 (0.0571)

- 8) Fit thrust washers into extension case.
 - 9) Install bearing cone into extension case.
 - 10) Measure depth "S" between transfer case and center differential.
- ST 398643600 GAUGE

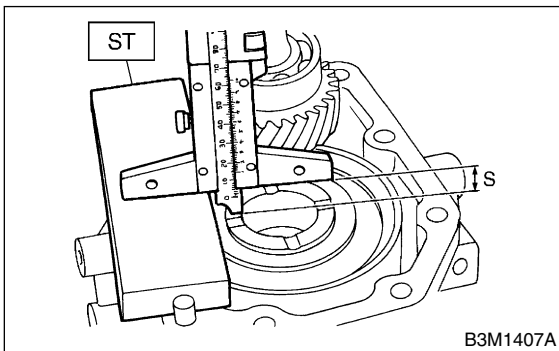

- 11) Measure depth "T" between extension case and transfer drive gear.
- ST 398643600 GAUGE

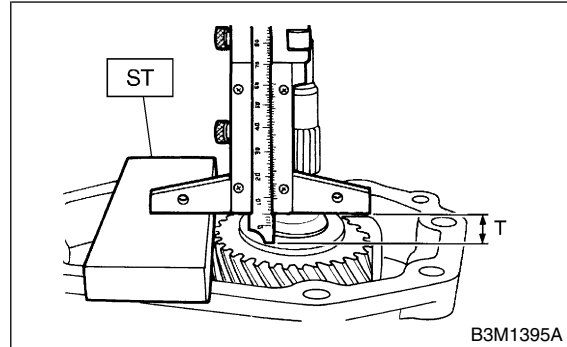

- 12) Calculate space "U" using the following equation: $U = S + T - 30 \text{ mm (1.8 in)}$ [Thickness of ST]
- 13) Select suitable washer in the following table:

Standard clearance:
0.15 — 0.35 mm (0.0059 — 0.0138 in)

Thrust washer	
Part No.	Thickness mm (in)
803036050	0.9 (0.035)
803036054	1.0 (0.039)
803036051	1.1 (0.043)
803036055	1.2 (0.047)
803036052	1.3 (0.051)
803036056	1.4 (0.055)
803036053	1.5 (0.059)
803036057	1.6 (0.063)
803036058	1.7 (0.067)

- 14) Fit thrust washer on center differential.
- 15) Apply proper amount of liquid gasket to the transfer case mating surface.

Liquid gasket:
THREE BOND 1215

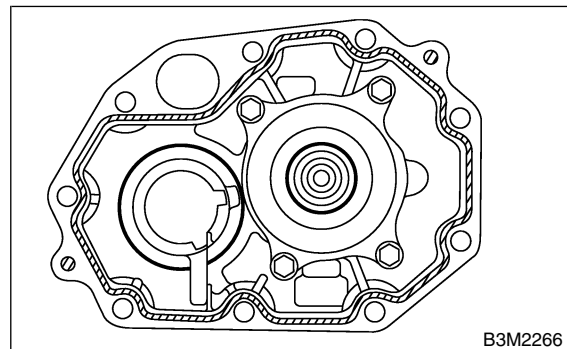

TRANSFER CASE AND EXTENSION CASE ASSEMBLY

Manual Transmission and Differential

16) Install extension assembly into transfer case.

Tightening torque:

40 N·m (4.1 kgf·m, 29.7 ft·lb)

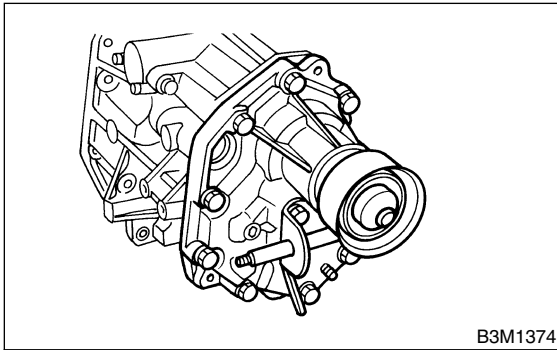

17) Install shifter arm to transfer case.

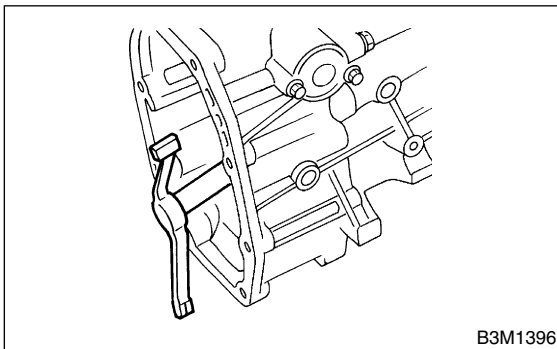

18) Hang the shifter arm on the 3rd-4th fork rod.

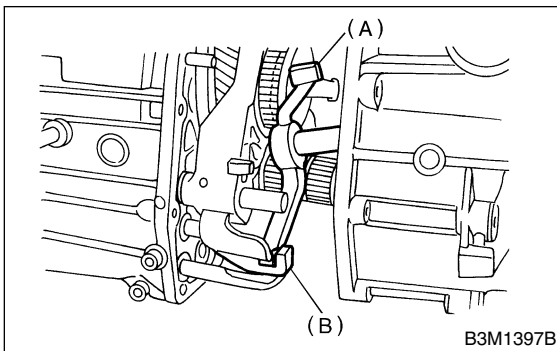

19) Install transfer case with extension case assembly to transmission case.

Tightening torque:

25 N·m (2.5 kgf·m, 18.1 ft·lb)

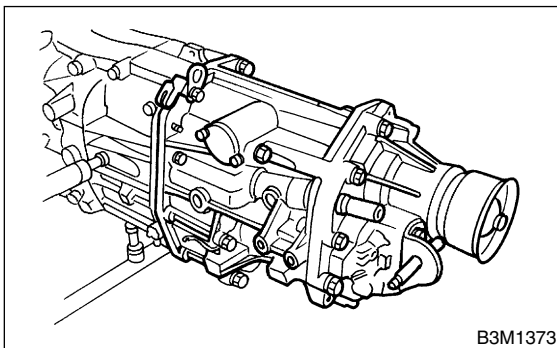

C: DISASSEMBLY S503561A06

1. TRANSFER CASE S503561A0601

- 1) Remove reverse check assembly. <Ref. to MT-48, REMOVAL, Reverse Check Sleeve.>
- 2) Remove oil guide.

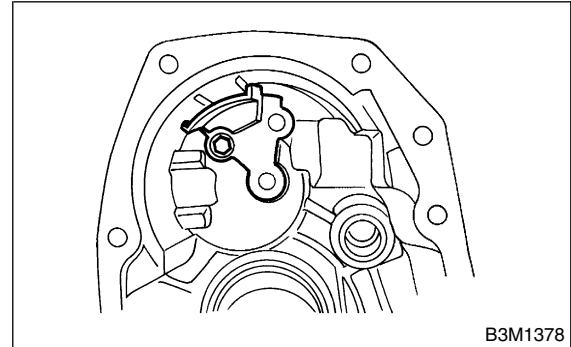

2. EXTENSION CASE S503561A0602

- 1) Remove transfer drive gear assembly. <Ref. to MT-43, REMOVAL, Transfer Drive Gear.>
- 2) Remove shift bracket.

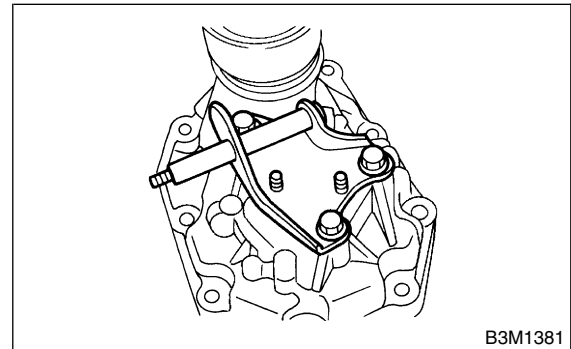

- 3) Remove oil seal from extension case. <Ref. to MT-34, Oil Seal.>

TRANSFER CASE AND EXTENSION CASE ASSEMBLY

Manual Transmission and Differential

D: ASSEMBLY S503561A02

1. EXTENSION CASE S503561A0201

- 1) Using ST, install oil seal to extension case.
<Ref. to MT-34, Oil Seal.>

CAUTION:

Use new oil seal.

- 2) Install shift bracket to extension case.

Tightening torque:

25 N·m (2.5 kgf-m, 18.1 ft-lb)

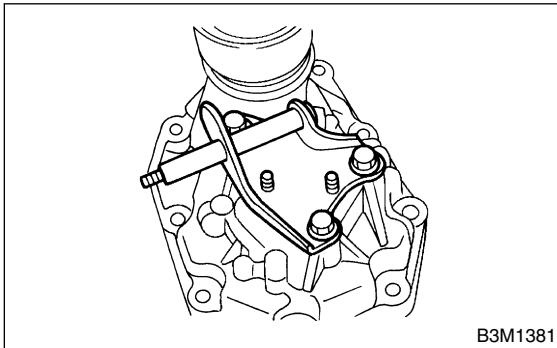

- 3) Install transfer drive gear to extension case.
<Ref. to MT-43, INSTALLATION, Transfer Drive Gear.>

2. TRANSFER CASE S503561A0202

- 1) Install oil guide to transfer case.

Tightening torque:

6.4 N·m (0.65 kgf-m, 4.7 ft-lb)

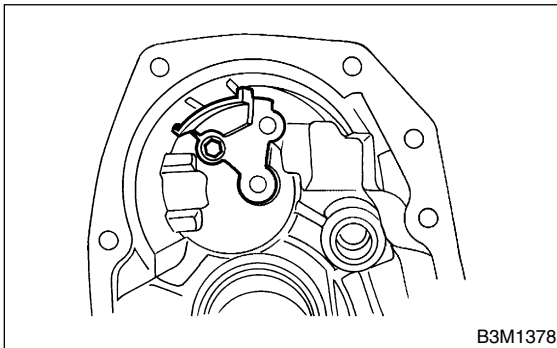

- 2) Install reverse check sleeve assembly to transfer case. <Ref. to MT-48, INSTALLATION, Reverse Check Sleeve.>