

# REVERSE CHECK SLEEVE

Manual Transmission and Differential

## 13. Reverse Check Sleeve S503267

### A: REMOVAL S503267A18

- 1) Remove the manual transmission assembly from vehicle. <Ref. to MT-27, REMOVAL, Manual Transmission Assembly.>
- 2) Remove the transfer case with extension case assembly. <Ref. to MT-39, REMOVAL, Transfer Case and Extension Case Assembly.>
- 3) Remove shifter arm.
- 4) Remove plug, spring washer and reverse check ball.

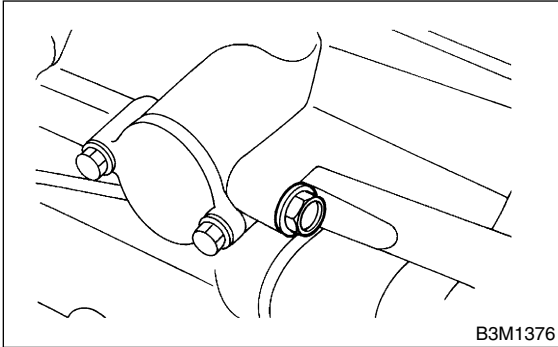

- 5) Remove the reverse check sleeve.

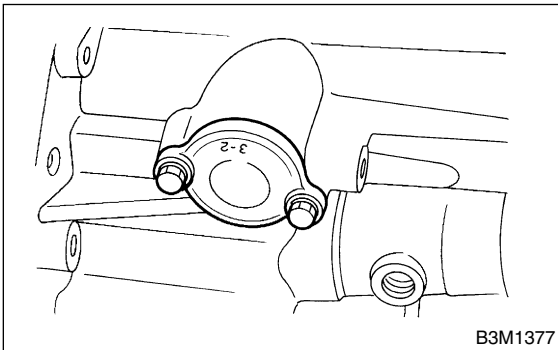

### B: INSTALLATION S503267A11

- 1) Install the reverse check sleeve.

#### Tightening torque:

**6.4 N·m (0.65 kgf-m, 4.7 ft-lb)**

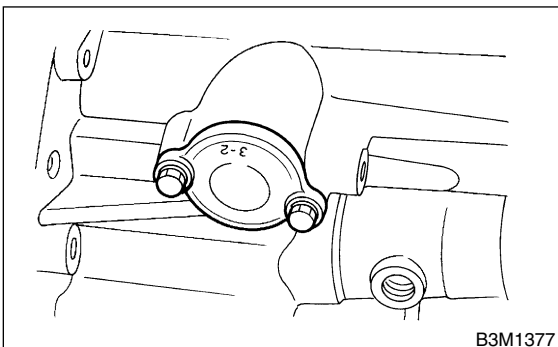

- 2) Install ball, spring, washer and plug to transfer case.

#### Tightening torque:

**10 N·m (1.0 kgf-m, 7.2 ft-lb)**

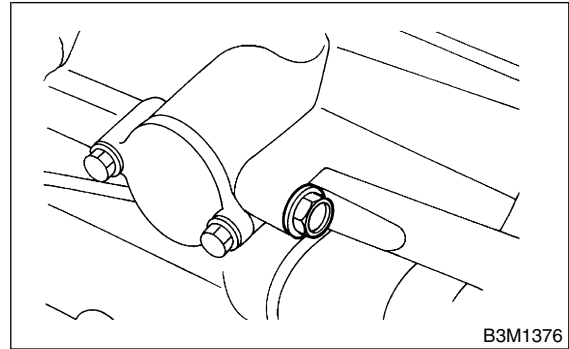

- 3) Install the shifter arm to transfer case assembly.
- 4) Install the transfer case with extension case assembly. <Ref. to MT-39, INSTALLATION, Transfer Case and Extension Case Assembly.>
- 5) Install the manual transmission assembly to vehicle. <Ref. to MT-29, INSTALLATION, Manual Transmission Assembly.>

### C: DISASSEMBLY S503267A06

- 1) Cover the reverse check sleeve with a rag, and remove snap ring using a screwdriver.

#### NOTE:

Replace snap ring with a new one if deformed or weakened.

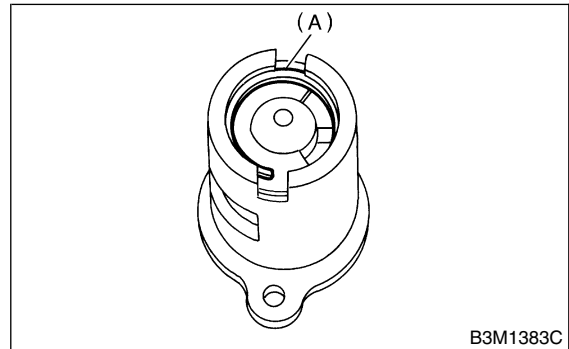

- (A) Snap ring

2) Remove reverse check plate, reverse check spring, reverse check cam, return spring (5th-Rev), reverse accent shaft, return spring cap and return spring (1st-2nd).

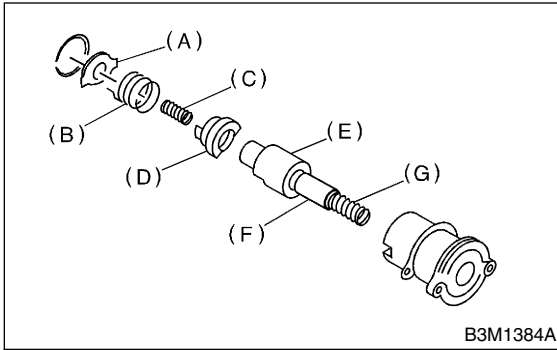

- (A) Reverse check plate
- (B) Reverse check spring
- (C) Return spring (5th-Rev)
- (D) Reverse check cam
- (E) Reverse accent shaft
- (F) Return spring cap
- (G) Return spring (1st-2nd)

3) Remove O-ring.

**NOTE:**

- Reverse check sleeve assembly uses an O-ring which should not be scratched.
- Be careful not to break adjustment shim placed between reverse check sleeve assembly and case.

**D: ASSEMBLY** S503267A02

1) Install return spring (1st-2nd), return spring cap, reverse accent shaft, check cam, return spring and check spring onto reverse check sleeve.

**NOTE:**

Be sure the bent section of reverse check spring is positioned in the groove in check cam.

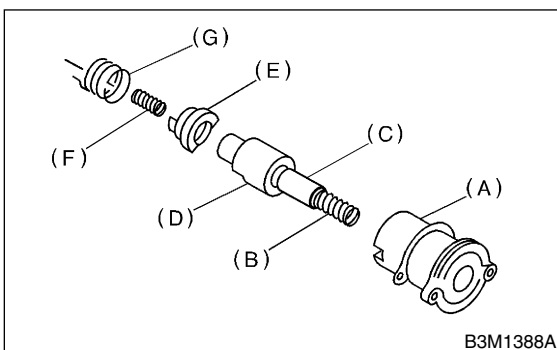

- (A) Reverse check sleeve
- (B) Return spring (1st-2nd)
- (C) Return spring cap
- (D) Reverse accent shaft
- (E) Return spring (5th-Rev)
- (F) Reverse check cam
- (G) Reverse check spring

- 2) Hook the bent section of reverse check spring over reverse check plate.
- 3) Rotate cam so that the protrusion of reverse check cam is at the opening in plate.
- 4) With cam held in that position, install plate onto reverse check sleeve and hold with snap ring.
- 5) Position O-ring in groove in sleeve.

**E: INSPECTION** S503267A10

- Make sure the cutout section of reverse accent shaft is aligned with the opening in reverse check sleeve.
- Spin cam by hand for smooth rotation.
- Move cam and shaft all the way toward plate and release.

If cam does not return properly, replace reverse check spring; if shaft does not, check for scratches on the inner surface of sleeve. If sleeve is in good order, replace spring.

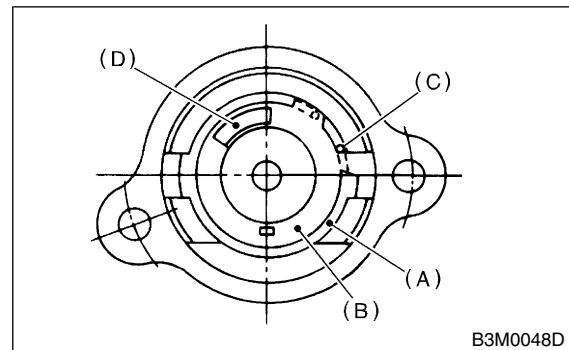

- (A) Snap ring
- (B) Reverse check plate
- (C) Check spring
- (D) Check cam

- Select a suitable reverse accent shaft and reverse check plate. <Ref. to MT-50, ADJUSTMENT, Reverse Check Sleeve.>

# REVERSE CHECK SLEEVE

Manual Transmission and Differential

## F: ADJUSTMENT S503267A01

### 1. NEUTRAL POSITION ADJUSTMENT

S503267A0101

- 1) Shift gear into 3rd gear position.
- 2) Shifter arm turns lightly toward the 1st/2nd gear side but heavily toward the reverse gear side because of the function of the return spring, until arm contacts the stopper.
- 3) Make adjustment so that the heavy stroke (reverse side) is a little more than the light stroke (1st/2nd side).
- 4) To adjust, remove bolts holding reverse check sleeve assembly to the case, move sleeve assembly outward, and place adjustment shim (0 to 1 ea.) between sleeve assembly and case to adjust the clearance.

#### NOTE:

- Be careful not to break O-ring when placing shim(s).
- When shim is removed, the neutral position will move closer to reverse; when shim is added, the neutral position will move closer to 1st gear.
- If shims alone cannot adjust the clearance, replace reverse accent shaft and re-adjust.

Adjustment shim	
Part No.	Thickness mm (in)
32190AA000	0.15 (0.0059)
32190AA010	0.30 (0.0118)

Reverse accent shaft		
Part No.	Mark	Remarks
32188AA090	3	Neutral position is closer to 1st gear.
32188AA100	0	Standard
32188AA110	1	Neutral position is closer to reverse gear.

### 2. REVERSE CHECK PLATE ADJUSTMENT S503267A0102

- 1) Shift shifter arm to "5th" and then to reverse to see if reverse check mechanism operates properly.
- 2) Also check to see if arm returns to neutral when released from the reverse position. If arm does not return properly, replace reverse check plate.

Reverse check plate			
Part No.	(A): No.	Angle $\theta$	Remarks
32189AA000	0	28°	Arm stops closer to 5th gear.
32189AA010	1	31°	Arm stops closer to 5th gear.
32189AA020	2	34°	Arm stops in the center.
32189AA030	3	37°	Arm stops closer to reverse gear.
32189AA040	4	40°	Arm stops closer to reverse gear.

