

# MAIN SHAFT ASSEMBLY FOR SINGLE-RANGE

Manual Transmission and Differential

## 15. Main Shaft Assembly for Single-Range

S503713

### A: REMOVAL

S503713A18

- 1) Remove the manual transmission assembly from vehicle. <Ref. to MT-27, REMOVAL, Manual Transmission Assembly.>
- 2) Remove transfer case with extension case assembly. <Ref. to MT-39, REMOVAL, Transfer Case and Extension Case Assembly.>
- 3) Remove transmission case. <Ref. to MT-51, REMOVAL, Transmission Case.>
- 4) Remove drive pinion shaft assembly. <Ref. to MT-60, REMOVAL, Drive Pinion Shaft Assembly.>
- 5) Remove main shaft assembly.

### B: INSTALLATION

S503713A11

- 1) Install the needle bearing and new oil seal onto the front of transmission main shaft assembly.

#### NOTE:

- Wrap clutch splined section with vinyl tape to prevent damage to oil seal.
- Apply grease (Unilube #2 or equivalent) to the sealing lip of oil seal.

- 2) Install needle bearing outer race knock pin hole into transmission case knock pin.

#### NOTE:

Align the end face of seal with surface (A) when installing oil seal.

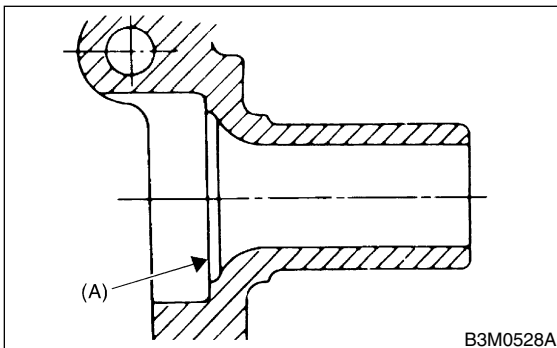

- 3) Install the drive pinion assembly. <Ref. to MT-60, INSTALLATION, Drive Pinion Shaft Assembly.>
- 4) Install transmission case. <Ref. to MT-51, INSTALLATION, Transmission Case.>
- 5) Install transfer case with extension case assembly. <Ref. to MT-39, INSTALLATION, Transfer Case and Extension Case Assembly.>
- 6) Install the manual transmission assembly to vehicle. <Ref. to MT-29, INSTALLATION, Manual Transmission Assembly.>

### C: DISASSEMBLY

S503713A06

- 1) Put vinyl tape around main shaft splines to protect oil seal from damage. Then pull out oil seal and needle bearing by hand.
- 2) Remove lock nut from transmission main shaft assembly.

#### NOTE:

Remove caulking before taking off lock nut.

- ST1 498937000 TRANSMISSION HOLDER  
ST2 499987003 SOCKET WRENCH (35)

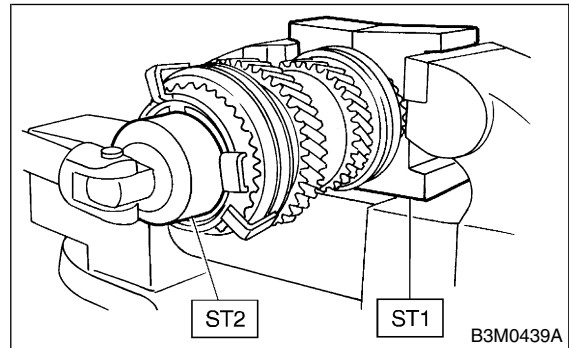

- 3) Remove 5th-Rev sleeve and hub assembly, baulk ring, 5th drive gear and needle bearing.

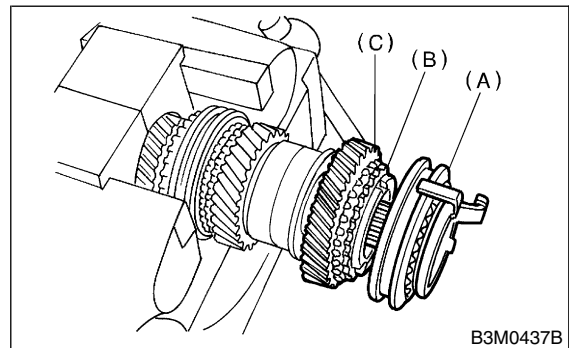

- (A) 5th-Rev sleeve and hub ASSY  
(B) Baulk ring  
(C) 5th drive gear

# MAIN SHAFT ASSEMBLY FOR SINGLE-RANGE

Manual Transmission and Differential

4) Remove snap ring and synchro cone stopper from 5th-Rev sleeve and hub assembly.

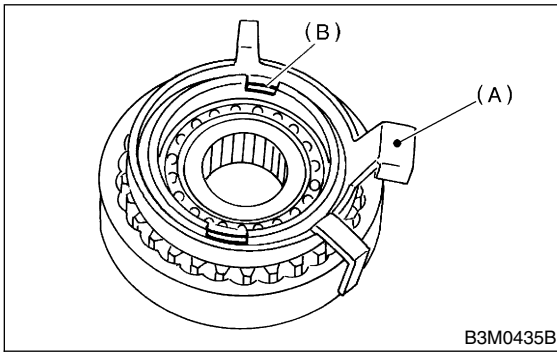

- (A) Synchro cone stopper
- (B) Snap ring

5) Using ST1, ST2 and a press, remove ball bearing, synchro cone and baulk ring (Rev).

NOTE:

- Replace sleeve and hub with new ones. Do not attempt to disassemble because they must engage at a specified point. If they should be disassembled, mark engagement point on splines beforehand.

- Do not reuse ball bearing.

ST1 499757002 INSTALLER  
ST2 498077400 SYNCHRO CONE  
REMOVER

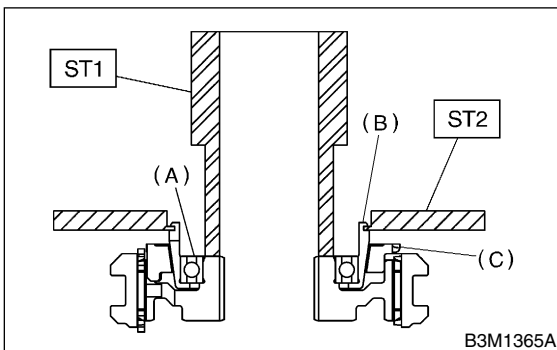

- (A) Ball bearing
- (B) Synchro cone
- (C) Baulk ring

6) Using ST1 and ST2, remove the rest of parts.

NOTE:

Replace sleeve and hub with new ones. Do not attempt to disassemble because they must engage at a specified point. If they should be disassembled, marking engagement point on splines beforehand.

ST1 899864100 REMOVER  
ST2 899714110 REMOVER

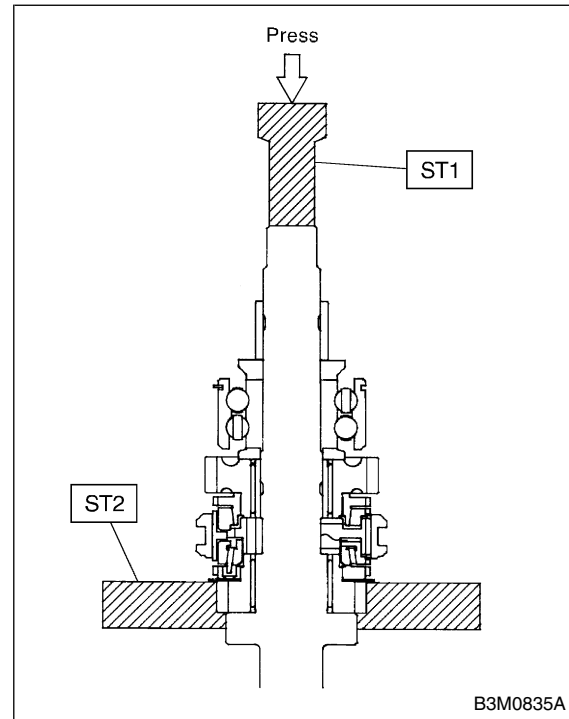

# MAIN SHAFT ASSEMBLY FOR SINGLE-RANGE

Manual Transmission and Differential

## D: ASSEMBLY S503713A02

1) Assemble each sleeve and hub assembly.

NOTE:

Position open ends of spring 120° apart.

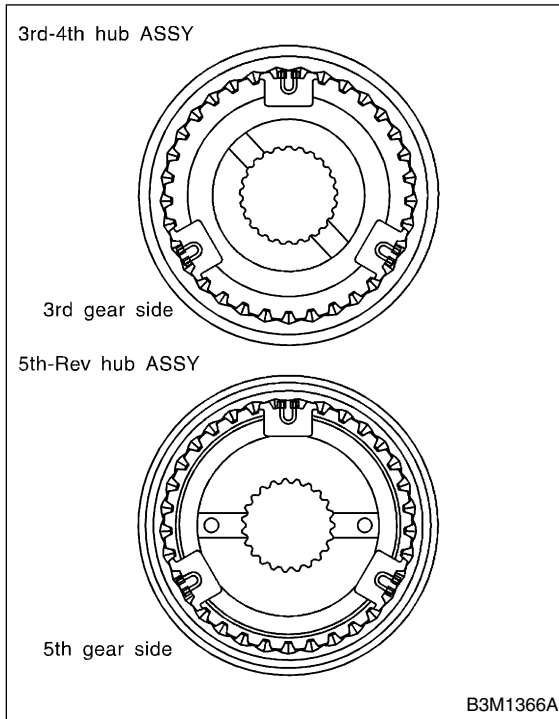

2) Install 3rd drive gear, outer baulk ring, synchro cone, inner baulk ring, sleeve and hub assembly for 3rd needle bearing on transmission main shaft.

NOTE:

Align groove in baulk ring with shifting insert.

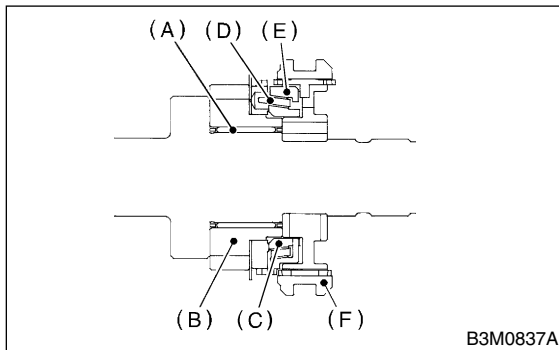

- (A) 3rd needle bearing
- (B) 3rd drive gear
- (C) Inner baulk ring
- (D) Synchro cone
- (E) Outer baulk ring
- (F) Sleeve and hub ASSY

3) Install 4th needle bearing race onto transmission main shaft using ST1, ST2 and a press.

**CAUTION:**

**Do not apply pressure in excess of 10 kN (1 ton, 1.1 US ton, 1.0 Imp ton).**

ST1 899714110 REMOVER

ST2 499877000 RACE 4-5 INSTALLER

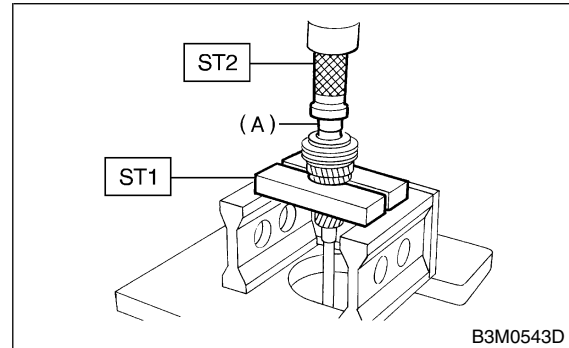

(A) 4th needle bearing race

4) Install baulk ring, needle bearing, 4th drive gear and 4th gear thrust washer to transmission main shaft.

NOTE:

Align baulk ring and gear & hub assembly with key groove.

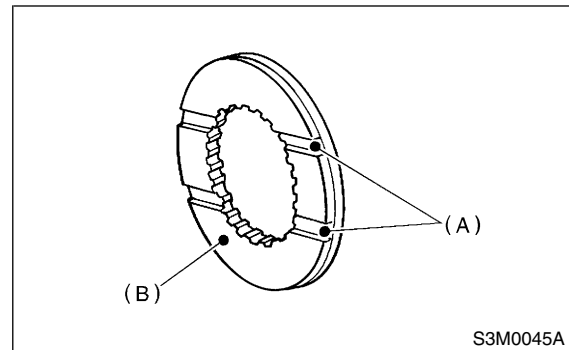

- (A) Groove
- (B) 4th gear side

# MAIN SHAFT ASSEMBLY FOR SINGLE-RANGE

Manual Transmission and Differential

5) Drive ball bearing onto the rear section of transmission main shaft using ST1, ST2 and a press.

**CAUTION:**

**Do not apply pressure in excess of 10 kN (1 ton, 1.1 US ton, 1.0 Imp ton).**

ST1 899714110 REMOVER  
ST2 499877000 RACE 4-5 INSTALLER

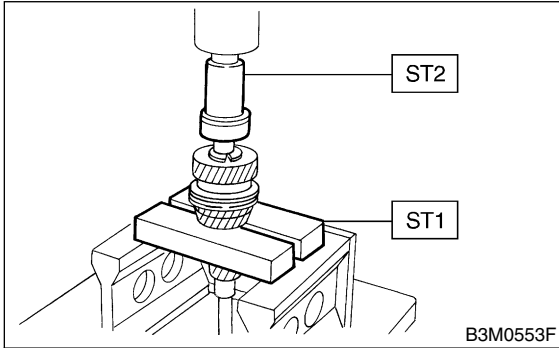

6) Using ST1 and ST2, install the 5th gear thrust washer and 5th needle bearing race onto the rear section of transmission main shaft.

**CAUTION:**

**Do not apply pressure in excess of 10 kN (1 ton, 1.1 US ton, 1.0 Imp ton).**

**NOTE:**

Face thrust washer in the correct direction.

ST1 899714110 REMOVER  
ST2 499877000 RACE 4-5 INSTALLER

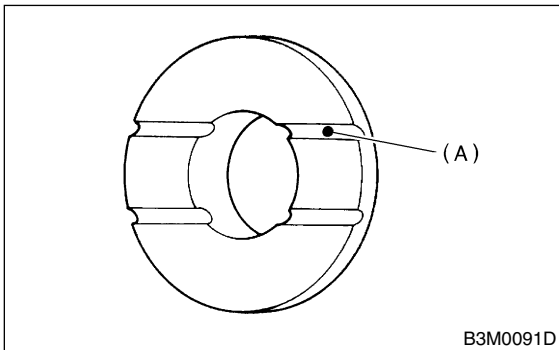

(A) Face this surface to 5th gear side.

7) Install bearing onto synchro cone.

8) Install baulk ring and synchro cone onto 5th-Rev sleeve and hub assembly using ST and a press.

**CAUTION:**

**Do not apply pressure in excess of 10 kN (1 ton, 1.1 US ton, 1.0 Imp ton).**

**NOTE:**

- Use new ball bearing.
- After press fitting, make sure synchro cone rotates freely.

ST 499757002 INSTALLER

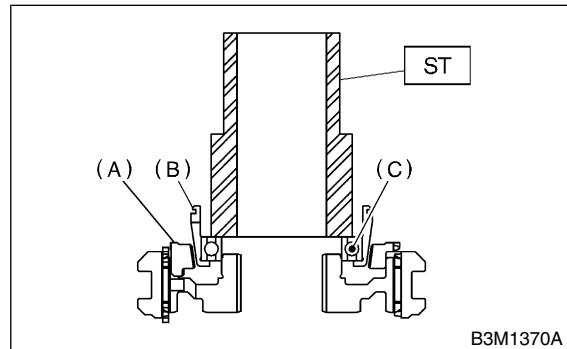

- (A) Baulk ring
- (B) Synchro cone
- (C) Ball bearing

9) Install synchro cone stopper and snap ring to 5th-Rev sleeve and hub assembly.

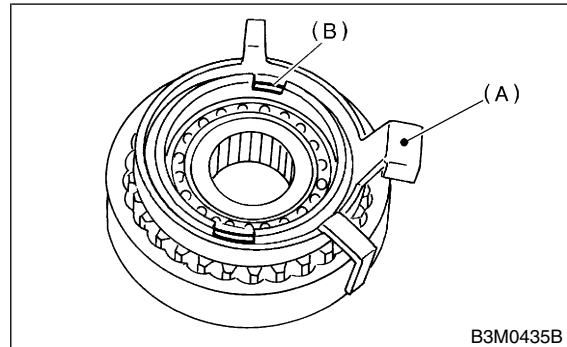

- (A) Synchro cone stopper
- (B) Snap ring

# MAIN SHAFT ASSEMBLY FOR SINGLE-RANGE

Manual Transmission and Differential

10) Install the rest parts to the rear section of transmission main shaft.

**NOTE:**

Align groove in baulk ring with shifting insert.

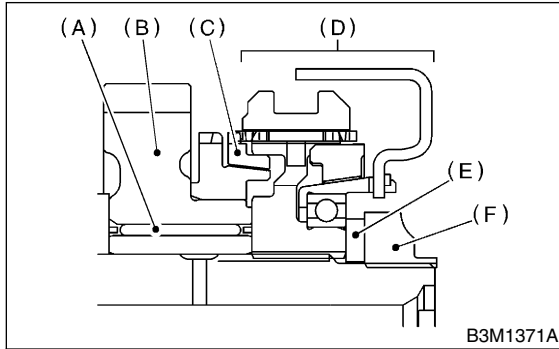

- (A) Needle bearing
- (B) 5th drive gear
- (C) Baulk ring
- (D) 5th-Rev sleeve and hub ASSY
- (E) Lock washer
- (F) Lock nuts

11) Tighten lock nuts to the specified torque using ST1 and ST2.

**NOTE:**

Secure lock nuts in two places after tightening.

- ST1 499987003 SOCKET WRENCH
- ST2 498937000 TRANSMISSION HOLDER

**Tightening torque:**

**118 N·m (12.0 kgf·m, 86.8 ft·lb)**

## E: INSPECTION

S503713A10

Disassembled parts should be washed clean first and then inspected carefully.

### 1) Bearings

Replace bearings in the following cases:

- Bearings whose balls, outer races and inner races are broken or rusty.
- Worn bearings
- Bearings that fail to turn smoothly or make abnormal noise when turned after gear oil lubrication.
- Bearings having other defects

### 2) Bushing (each gear)

Replace the bushing in the following cases:

- When the sliding surface is damaged or abnormally worn.
- When the inner wall is abnormally worn.

### 3) Gears

- Replace gears with new ones if their tooth surfaces are broken, damaged, or excessively worn.
- Correct or replace if the cone that contacts the baulk ring is rough or damaged.
- Correct or replace if the inner surface or end face is damaged.

### 4) Baulk ring

Replace the ring in the following cases:

- When the inner surface and end face are damaged.
- When the ring inner surface is abnormally or partially worn down.
- When the contact surface of the synchronizer ring insert is scored or abnormally worn down.

### 5) Shifting insert key

Replace the insert if deformed, excessively worn, or defective in any way.

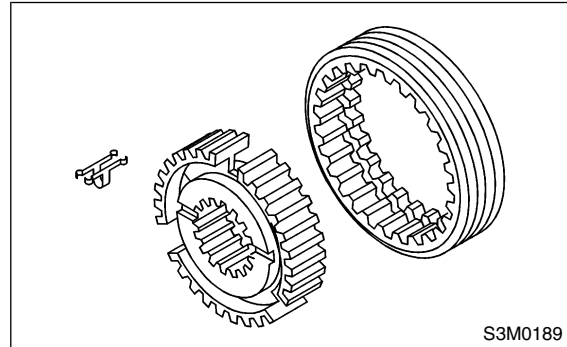

### 6) Oil seal

Replace the oil seal if the lip is deformed, hardened, damaged, worn, or defective in any way.

### 7) O-ring

Replace the O-ring if the sealing face is deformed, hardened, damaged, worn, or defective in any way.

### 8) Gearshift mechanism

Repair or replace the gearshift mechanism if excessively worn, bent, or defective in any way.

## F: ADJUSTMENT S503713A01

Selection of main shaft rear plate

Using ST, measure the amount (A) of ball bearing protrusion from transmission main case surface and select the proper plate in the following table:

NOTE:

Before measuring, tap the end of main shaft with a plastic hammer lightly in order to make the clearance zero between the main case surface and the moving flange of bearing.

ST 498147000 DEPTH GAUGE

Dimension (A) mm (in)	Part No.	Mark
4.00 — 4.13 (0.1575 — 0.1626)	32294AA041	1
3.87 — 3.99 (0.1524 — 0.1571)	32294AA051	2

