

## 19. Reverse Idler Gear S503263

### A: REMOVAL S503263A18

- 1) Remove the manual transmission assembly from vehicle. <Ref. to MT-27, REMOVAL, Manual Transmission Assembly.>
- 2) Remove back-up light switch and neutral position switch. <Ref. to MT-35, REMOVAL, Switches and Harness.>
- 3) Remove transfer case with extension case assembly. <Ref. to MT-39, REMOVAL, Transfer Case and Extension Case Assembly.>
- 4) Remove transmission case. <Ref. to MT-51, REMOVAL, Transmission Case.>
- 5) Remove drive pinion shaft assembly. <Ref. to MT-60, REMOVAL, Drive Pinion Shaft Assembly.>
- 6) Remove main shaft assembly. <Ref. to MT-54, REMOVAL, Main Shaft Assembly for Single-Range.>
- 7) Remove differential assembly. <Ref. to MT-69, REMOVAL, Front Differential Assembly.>
- 8) Remove shifter forks and rods. <Ref. to MT-79, REMOVAL, Shifter Fork and Rod.>
- 9) Pull out straight pin, and remove idler gear shaft, reverse idler gear and washer.

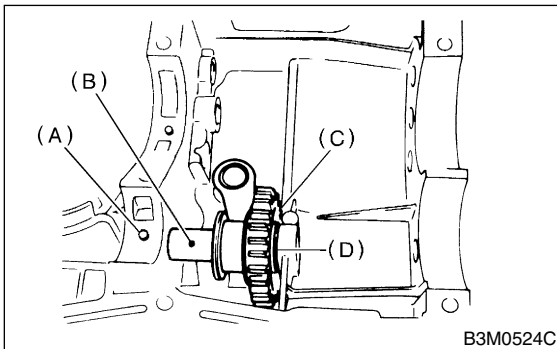

- (A) Straight pin
- (B) Idler gear shaft
- (C) Idler gear
- (D) Washer

- 10) Remove reverse shifter lever.

### B: INSTALLATION S503263A11

- 1) Install reverse shifter lever, reverse idler gear and reverse idler gear shaft, and secure with straight pin.

#### NOTE:

Be sure to install reverse idler shaft from the rear side.

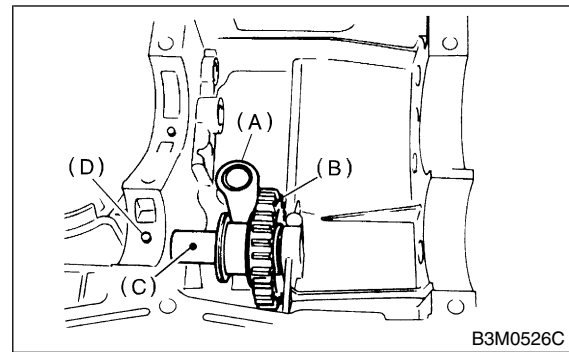

- (A) Reverse shifter lever
- (B) Reverse idler gear
- (C) Reverse idler gear shaft
- (D) Straight pin

- 2) Inspect and adjust clearance between reverse idler gear and transmission case wall. <Ref. to MT-78, INSPECTION, Reverse Idler Gear.> and <Ref. to MT-78, ADJUSTMENT, Reverse Idler Gear.>
- 3) Install shifter forks and rods. <Ref. to MT-79, INSTALLATION, Shifter Fork and Rod.>
- 4) Install differential assembly. <Ref. to MT-69, INSTALLATION, Front Differential Assembly.>
- 5) Install main shaft assembly. <Ref. to MT-54, INSTALLATION, Main Shaft Assembly for Single-Range.>
- 6) Install drive pinion shaft assembly. <Ref. to MT-60, INSTALLATION, Drive Pinion Shaft Assembly.>
- 7) Install transmission case. <Ref. to MT-51, INSTALLATION, Transmission Case.>
- 8) Install transfer case with extension case assembly. <Ref. to MT-39, INSTALLATION, Transfer Case and Extension Case Assembly.>
- 9) Install back-up light switch and neutral position switch. <Ref. to MT-35, INSTALLATION, Switches and Harness.>
- 10) Install the manual transmission assembly to vehicle. <Ref. to MT-29, INSTALLATION, Manual Transmission Assembly.>

# REVERSE IDLER GEAR

Manual Transmission and Differential

## C: INSPECTION S503263A10

1) Move the reverse shifter rod toward the reverse side. Inspect clearance between reverse idler gear and transmission case wall.

If out of specification, select the appropriate reverse shifter lever and adjust.

**Clearance A:**  
**6.0 — 7.5 mm (0.236 — 0.295 in)**

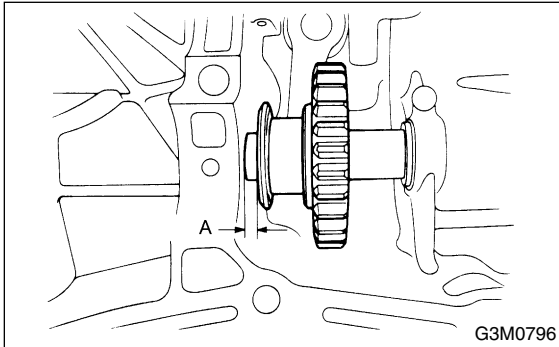

2) After installing a suitable reverse shifter lever, shift into neutral. Inspect clearance between reverse idler gear and transmission case wall.

If out of specification, select the appropriate washer and adjust.

**Clearance:**  
**0 — 0.5 mm (0 — 0.020 in)**

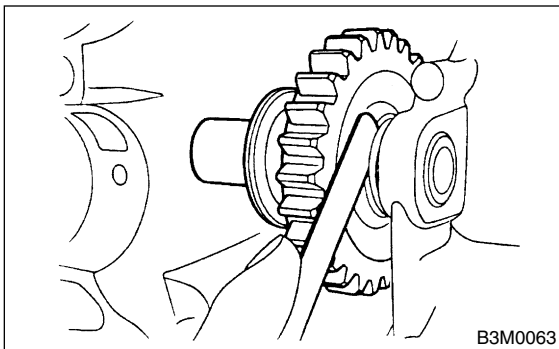

3) Check the reverse idler gear and shaft for damage. Replace if damaged.

## D: ADJUSTMENT S503263A01

1) Select the appropriate reverse shifter lever from the table below, and adjust until the gap between the reverse idler gear and transmission case wall is within specification.

**Clearance A:**  
**6.0 — 7.5 mm (0.236 — 0.295 in)**

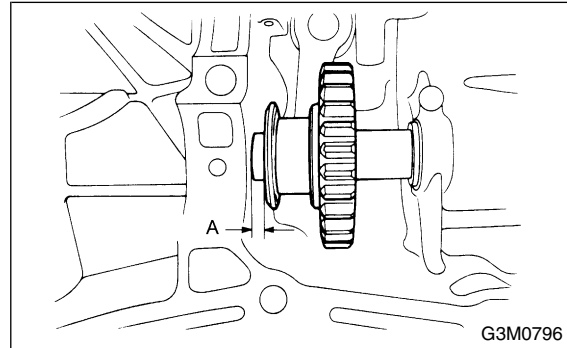

Reverse shifter lever		
Part No.	Mark	Remarks
32820AA070	7	Further from case wall
32820AA080	8	Standard
32820AA090	9	Closer to case wall

2) Select the appropriate washer from the table below, and adjust until the gap between the reverse idler gear and transmission case wall is within specification.

**Clearance:**  
**0 — 0.5 mm (0 — 0.020 in)**

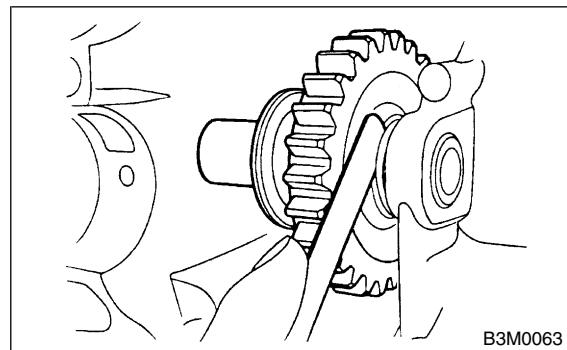

Washer	
Part No.	Thickness mm (in)
803020151	0.4 (0.016)
803020152	1.1 (0.043)
803020153	1.5 (0.059)
803020154	1.9 (0.075)
803020155	2.3 (0.091)