

ATTENTION:
 GENERALMANAGER PARTSMANAGER
 CLAIMSPERSONNEL SERVICEMANAGER
IMPORTANT - All Service Personnel Should Read and Initial



SERVICE BULLETIN

APPLICABILITY: 2000~2002 Impreza Service Manuals
 2000~2002 Legacy & Outback Service Manuals
 2000~2002 Forester Service Manuals

NUMBER: 18-69-01
DATE: 07/1/2001

SUBJECT: Service Manual Corrections

Place a REVISED label on the appropriate page of the noted effected Service Manual and update the Service Manual Correction Binder with the following pages:

Model	Year	Book/Vol #	MSA#	Section	Page	Reference
Forester	2000	5	MSA5T0024A	3-2	57	[T816]
Forester	2000	6	MSA5T0025A	4-4	73	[T8Y3]
Forester	2001	5	MSA5T0124A	3-2	57	[T816]
Forester	2001	6	MSA5T0125A	4-4	73	[T8Y3]
Forester	2002	5	MSA5T0224A	AT	AT-59	--
Forester	2002	6	MSA5T0225A	ABS	ABS-79	--
Impreza	2000	5	MSA5T0014A	3-2	59	[T816]
Impreza	2001	4	MSA5T0113A	AT	AT-49	--
Impreza	2001	4	MSA5T0113A	AT	AT-50	--
Impreza	2002	1	MSA5T0210A	PM	PM-20	--
Impreza	2002	4	MSA5T0213A	AT	AT-69	--
Legacy	2000	5	MSA5T0005A	3-2	59	[T816]
Legacy	2001	4	MSA5T0104A	AT	AT-72	--
Legacy	2001	6	MSA5T0106A	ABS	ABS-84	--
Legacy	2001	7	MSA5T0107A	CC	CC-30	--
Legacy	2001	7	MSA5T0107A	CC	CC-35	--
Legacy	2002	4	MSA5T0204A	AT	AT-73	--
Legacy	2002	6	MSA5T0206A	ABS	ABS-75	--
Legacy	2002	1	MSA5T0201A	PM	PM-8	--
Legacy	2002	1	MSA5T0201A	PM	PM-23	--
Legacy	2002	1	MSA5T0201A	PM	PM-24	--
Legacy	2002	3	MSA5T0203A	EN(H6)	EN(H6)-29	--



CAUTION: VEHICLE SERVICING PERFORMED BY UNTRAINED PERSONS COULD RESULT IN SERIOUS INJURY TO THOSE PERSONS OR TO OTHERS.

Subaru Service Bulletins are intended for use by professional technicians ONLY. They are written to inform those technicians of conditions that may occur in some vehicles, or to provide information that could assist in the proper servicing of the vehicle. Properly trained technicians have the equipment, tools, safety instructions, and know-how to do the job correctly and safely. If a condition is described, DO NOT assume that this Service Bulletin applies to your vehicle, or that your vehicle will have that condition.

813 : PREPARE SUBARU SELECT MONITOR.

- CHECK** : *Do you have a Subaru Select Monitor?*
- YES** : Go to step **815**.
- NO** : Go to step **814**.

814 : CHECK INPUT SIGNAL FOR TCM.

- 1) Connect connectors to TCM and ECM.
- 2) Start the engine, and warm-up the transmission until ATF temperature is above 80°C (176°F).

NOTE:

If ambient temperature is below 0°C (32°F), drive the vehicle until the ATF reaches its operating temperature.

- 3) Engine idling.
- 4) Measure voltage between TCM connectors.

Connector & terminal

(B55) No. 20 (+) — No. 19 (-):

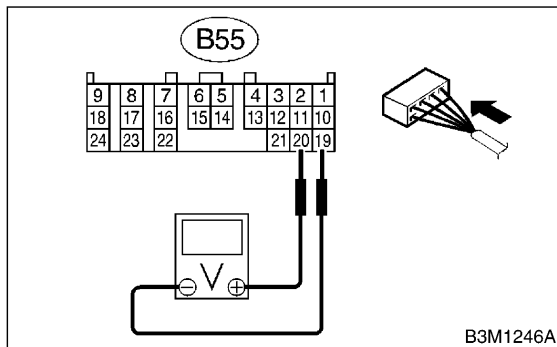

- CHECK** : *Is the voltage between 0.4 and 1.6V?*
- YES** : Even if "AT OIL TEMP" lights up, the circuit has returned to a normal condition at this time. A temporary poor contact of the connector or harness may be the cause. Repair harness or connector in the TCM and ECM.
- NO** : Go to step **816**.

815 : CHECK INPUT SIGNAL FOR TCM USING SUBARU SELECT MONITOR.

- 1) Connect connectors to TCM and ECM.
- 2) Turn ignition switch to OFF.
- 3) Connect Subaru Select Monitor to data link connector.

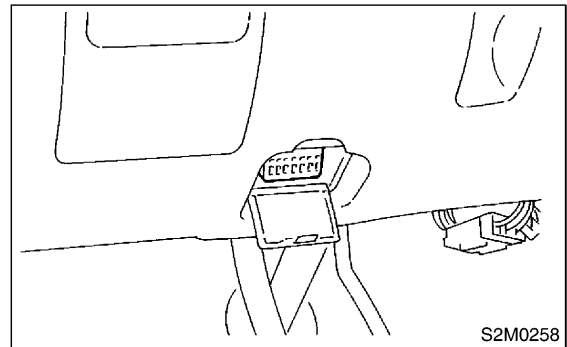

- 4) Start the engine, and turn Subaru Select monitor switch to ON.
 - 5) Warm-up the engine until engine coolant temperature is above 80°C (176°F).
 - 6) Engine idling.
 - 7) Read data of intake manifold pressure signal using Subaru Select Monitor.
- Display shows intake manifold pressure signal value sent from ECM.

- CHECK** : *Is the value between 0.4 and 1.6 V?*
- YES** : Even if "AT OIL TEMP" lights up, the circuit has returned to a normal condition at this time. A temporary poor contact of the connector or harness may be the cause. Repair harness or connector in the TCM and ECM.
- NO** : Go to step **816**.

816 : CHECK POOR CONTACT.

- CHECK** : *Is there poor contact in intake manifold pressure signal circuit?*
- YES** : Repair poor contact.
- NO** : Replace TCM. <Ref. to 3-2 [W23A0].>

8Y1 : CHECK ALL FOUR WHEELS FOR FREE TURNING.

- CHECK** : *Have the wheels been turned freely such as when the vehicle is lifted up, or operated on a rolling road?*
- YES** : The ABS is normal. Erase the trouble code. <Ref. to 4-4 [T6D2].>
- NO** : Go to step **8Y2**.

8Y2 : CHECK SPECIFICATIONS OF ABSCM&H/U.

Check specifications of the mark to the ABSCM&H/U.

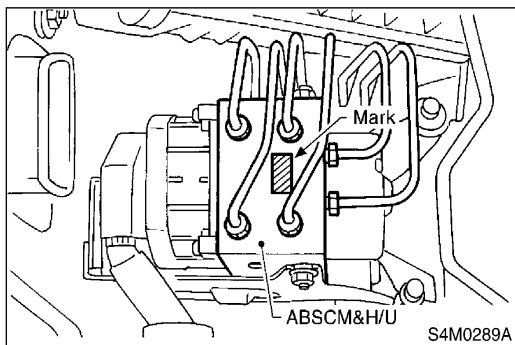

Mark	Model
C7	AWD AT
C8	AWD MT

- CHECK** : *Does the vehicle specification and the ABSCM&H/U specification match?*
- YES** : Go to step **8Y3**.

CAUTION:

Be sure to turn ignition switch to OFF when removing ABSCM&H/U.

- NO** : Replace ABSCM&H/U. <Ref. to 4-4 [W14A0].>

8Y3 : CHECK INPUT VOLTAGE OF G SENSOR.

- 1) Turn ignition switch to OFF.
- 2) Remove console box.
- 3) Disconnect G sensor from body. (Do not disconnect connector.)
- 4) Turn ignition switch to ON.
- 5) Measure voltage between G sensor connector terminals.

Connector & terminal

(R70) No. 1 (+) — No. 3 (-):

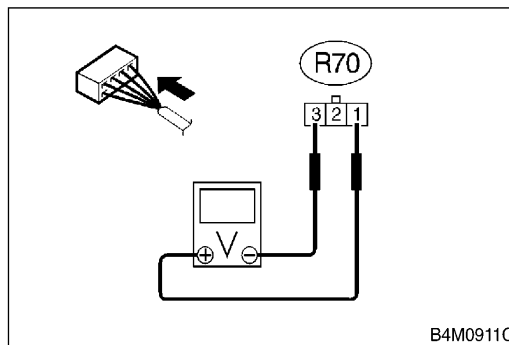

- CHECK** : *Is the voltage between 4.75 and 5.25 V?*
- YES** : Go to step **8Y4**.
- NO** : Repair harness/connector between G sensor and ABSCM&H/U.

DIAGNOSTIC PROCEDURE WITH DIAGNOSTIC TROUBLE CODE (DTC)

Automatic Transmission (Diagnostics)

No.	Step	Check	Yes	No
5	<p>CHECK INPUT SIGNAL FOR TCM.</p> <p>1) Connect connectors to TCM and ECM. 2) Start the engine, and warm-up the transmission until ATF temperature is above 80 C (176 F). NOTE: If ambient temperature is below 0 C (32 F), drive the vehicle until the ATF reaches its operating temperature. 3) Engine idling. 4) Measure voltage between TCM connector and chassis ground.</p> <p style="text-align: center;">Connector & terminal (B55) No. 20 (+) Chassis ground (-):</p>	Is the voltage between 0.4 and 1.6 V?	Even if AT OIL TEMP warning lights up, the circuit has returned to a normal condition at this time. A temporary poor contact of the connector or harness may be the cause. Repair harness or connector in the TCM and ECM.	Go to step 7.
6	<p>CHECK INPUT SIGNAL FOR TCM USING SUBARU SELECT MONITOR.</p> <p>1) Connect connectors to TCM and ECM. 2) Connect Subaru Select Monitor to data link connector. 3) Start the engine, and turn Subaru Select monitor switch to ON. 4) Warm-up the engine until engine coolant temperature is above 80 C (176 F). 5) Engine idling. 6) Read data of intake manifold pressure signal using Subaru Select Monitor. ● Display shows intake manifold pressure signal value sent from ECM.</p>	Is the value between 0.4 and 1.6 V?	Even if AT OIL TEMP warning lights up, the circuit has returned to a normal condition at this time. A temporary poor contact of the connector or harness may be the cause. Repair harness or connector in the TCM and ECM.	Go to step 7.
7	<p>CHECK POOR CONTACT.</p>	Is there poor contact in intake manifold pressure signal circuit?	Repair poor contact.	Replace TCM. <Ref. to AT-45, Transmission Control Module (TCM).>

DIAGNOSTICS PROCEDURE WITH DIAGNOSIS CONNECTOR

ABS (Diagnostics)

No.	Step	Check	Yes	No
1	CHECK ALL FOUR WHEELS FOR FREE TURNING.	Have the wheels been turned freely such as when the vehicle is lifted up, or operated on a rolling road?	The ABS is normal. Erase the DTC.	Go to step 2.
2	CHECK SPECIFICATIONS OF ABSCM&H/U. Check specifications of the mark to the ABSCM&H/U. C7: AT C8: MT	Does the vehicle specification and the ABSCM&H/U specification match?	Go to step 3.	Replace ABSCM&H/U. <Ref. to ABS-7, ABS Control Module and Hydraulic Control Unit (ABSCM&H/U).> CAUTION: Be sure to turn ignition switch to OFF when removing ABSCM&H/U.
3	CHECK INPUT VOLTAGE OF G SENSOR. 1) Turn ignition switch to OFF. 2) Remove console box. 3) Disconnect G sensor from body. (Do not disconnect connector.) 4) Turn ignition switch to ON. 5) Measure voltage between G sensor connector terminals. Connector & terminal (R70) No. 1 (+) No. 3 (-):	Is the voltage between 4.75 and 5.25 V?	Go to step 4.	Repair harness/connector between G sensor and ABSCM&H/U.
4	CHECK OPEN CIRCUIT IN G SENSOR OUTPUT HARNESS AND GROUND HARNESS. 1) Turn ignition switch to OFF. 2) Disconnect connector from ABSCM&H/U. 3) Measure resistance between ABSCM&H/U connector terminals. Connector & terminal (F49) No. 6 No. 28:	Is the resistance between 4.3 and 4.9 k Ω ?	Go to step 5.	Repair harness/connector between G sensor and ABSCM&H/U.
5	CHECK GROUND SHORT IN G SENSOR OUTPUT HARNESS. 1) Disconnect connector from G sensor. 2) Measure resistance between ABSCM&H/U connector and chassis ground. Connector & terminal (F49) No. 6 Chassis ground:	Is the resistance more than 1 M Ω ?	Go to step 6.	Repair harness between G sensor and ABSCM&H/U.
6	CHECK BATTERY SHORT OF HARNESS. Measure voltage between ABSCM&H/U connector and chassis ground. Connector & terminal (F49) No. 6 (+) Chassis ground (-):	Is the voltage less than 1 V?	Go to step 7.	Repair harness between G sensor and ABSCM&H/U.
7	CHECK BATTERY SHORT OF HARNESS. 1) Turn ignition switch to ON. 2) Measure voltage between ABSCM&H/U connector and chassis ground. Connector & terminal (F49) No. 6 (+) Chassis ground (-):	Is the voltage less than 1 V?	Go to step 8.	Repair harness between G sensor and ABSCM&H/U.

813 : PREPARE SUBARU SELECT MONITOR.

CHECK : *Do you have a Subaru Select Monitor?*

YES : Go to step 815.

NO : Go to step 814.

814 : CHECK INPUT SIGNAL FOR TCM.

- 1) Connect connectors to TCM and ECM.
- 2) Start the engine, and warm-up the transmission until ATF temperature is above 80°C (176°F).

NOTE:

If ambient temperature is below 0°C (32°F), drive the vehicle until the ATF reaches its operating temperature.

- 3) Engine idling.
- 4) Measure voltage between TCM connectors.

Connector & terminal

(B55) No. 20 (+) — No. 19 (-):

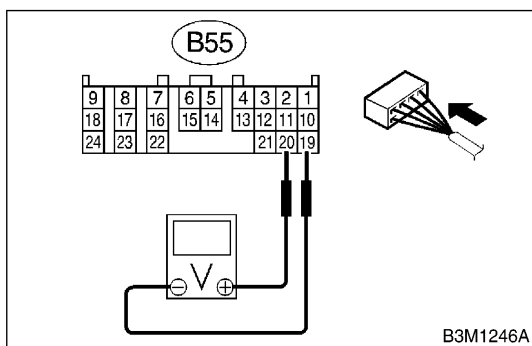

CHECK : *Is the voltage between 0.4 and 1.6 V?*

YES : Even if "AT OIL TEMP" lights up, the circuit has returned to a normal condition at this time. A temporary poor contact of the connector or harness may be the cause. Repair harness or connector in the TCM and ECM.

NO : Go to step 816.

815 : CHECK INPUT SIGNAL FOR TCM USING SUBARU SELECT MONITOR.

- 1) Connect connectors to TCM and ECM.
- 2) Turn ignition switch to OFF.
- 3) Connect Subaru Select Monitor to data link connector.

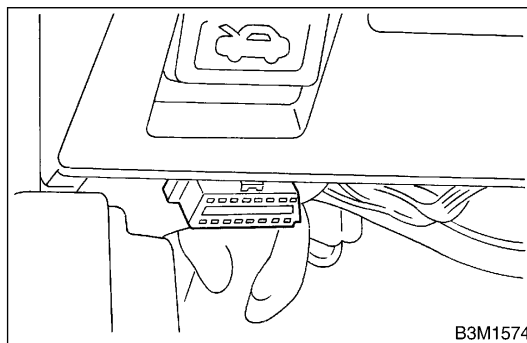

- 4) Start the engine, and turn Subaru Select monitor switch to ON.
- 5) Warm-up the engine until engine coolant temperature is above 80°C (176°F).
- 6) Engine idling.
- 7) Read data of intake manifold pressure signal using Subaru Select Monitor.

● Display shows intake manifold pressure signal value sent from ECM.

CHECK : *Is the value between 0.4 and 1.6 V?*

YES : Even if "AT OIL TEMP" lights up, the circuit has returned to a normal condition at this time. A temporary poor contact of the connector or harness may be the cause. Repair harness or connector in the TCM and ECM.

NO : Go to step 816.

816 : CHECK POOR CONTACT.

CHECK : *Is there poor contact in intake manifold pressure signal circuit?*

YES : Repair poor contact.

NO : Replace TCM. <Ref. to 3-2 [W23A0].>

DIAGNOSTIC PROCEDURE WITH TROUBLE CODE

Automatic Transmission

H: TROUBLE CODE 45 — INTAKE MANIFOLD PRESSURE SIGNAL — S004509D48

DIAGNOSIS:

Input signal circuit of TCM from ECM is open or shorted.

TROUBLE SYMPTOM:

Excessive shift shock.

WIRING DIAGRAM:

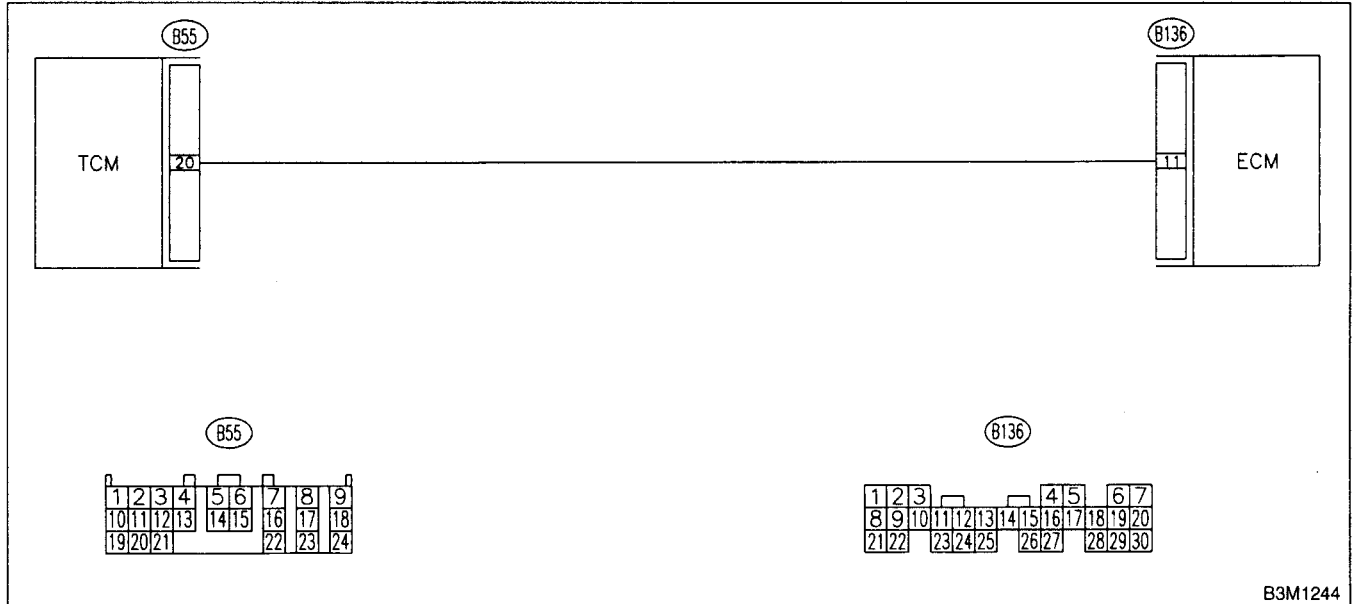

No.	Step	Check	Yes	No
1	CHECK HARNESS CONNECTOR BETWEEN TCM AND ECM. 1) Turn ignition switch to OFF. 2) Disconnect connectors from TCM and ECM. 3) Measure resistance of harness between TCM and ECM connector. <i>Connector & terminal (B55) No. 20 — (B136) No. 11:</i>	Is the resistance less than 1 Ω?	Go to step 2.	Repair open circuit in harness between TCM and ECM connector.
2	CHECK HARNESS CONNECTOR BETWEEN TCM AND ECM. Measure resistance of harness between TCM connector and chassis ground. <i>Connector & terminal (B55) No. 20 — Chassis ground:</i>	Is the resistance more than 1 MΩ?	Go to step 3.	Repair short circuit in harness between TCM and ECM connector.
3	PREPARE SUBARU SELECT MONITOR.	Do you have a Subaru Select Monitor?	Go to step 5.	Go to step 4.
4	CHECK INPUT SIGNAL FOR TCM. 1) Connect connectors to TCM and ECM. 2) Start the engine, and warm-up the transmission until ATF temperature is above 80°C (176°F). NOTE: If ambient temperature is below 0°C (32°F), drive the vehicle until the ATF reaches its operating temperature. 3) Engine idling. 4) Measure voltage between TCM connectors. <i>Connector & terminal (B55) No. 20 (+) — No. 19 (-):</i>	Is the voltage between 0.4 and 1.6 V?	Even if "AT OIL TEMP" lights up, the circuit has returned to a normal condition at this time. A temporary poor contact of the connector or harness may be the cause. Repair harness or connector in the TCM and ECM.	Go to step 6.

DIAGNOSTIC PROCEDURE WITH TROUBLE CODE

Automatic Transmission

No.	Step	Check	Yes	No
5	CHECK INPUT SIGNAL FOR TCM USING SUBARU SELECT MONITOR. 1) Connect connectors to TCM and ECM. 2) Turn ignition switch to OFF. 3) Connect Subaru Select Monitor to data link connector. 4) Start the engine, and turn Subaru Select monitor switch to ON. 5) Warm-up the engine until engine coolant temperature is above 80°C (176°F). 6) Engine idling. 7) Read data of intake manifold pressure signal using Subaru Select Monitor. ● Display shows intake manifold pressure signal value sent from ECM.	Is the value between 0.4 and 1.6 V?	Even if "AT OIL TEMP" lights up, the circuit has returned to a normal condition at this time. A temporary poor contact of the connector or harness may be the cause. Repair harness or connector in the TCM and ECM.	Go to step 6.
6	CHECK POOR CONTACT.	Is there poor contact in intake manifold pressure signal circuit?	Repair poor contact.	Replace TCM. <Ref. to AT-41 REMOVAL, Transmission Control Module (TCM).>

IDLE MIXTURE

PERIODIC MAINTENANCE SERVICES

Note: Idle Mixture is not adjustable on North American Market vehicles.

DIAGNOSTIC PROCEDURE WITH DIAGNOSTIC TROUBLE CODE (DTC)

AUTOMATIC TRANSMISSION (DIAGNOSTICS)

Step	Check	Yes	No
5 CHECK INPUT SIGNAL FOR TCM. 1) Connect the connectors to TCM and ECM. 2) Start the engine, and warm-up the transmission until the ATF temperature is above 80°C (176°F). NOTE: If ambient temperature is below 0°C (32°F), drive the vehicle until the ATF reaches its operating temperature. 3) Engine idling. 4) Measure the voltage between TCM connector and chassis ground. Connector & terminal (B55) No. 20 (+) — Chassis ground (-):	Is the voltage between 0.4 and 1.6 V?	Even if the AT OIL TEMP warning lights up, the circuit has returned to a normal condition at this time. A temporary poor contact of the connector or harness may be the cause. Repair harness or connector in the TCM and ECM.	Go to step 7.
6 CHECK INPUT SIGNAL FOR TCM USING SUBARU SELECT MONITOR. 1) Connect the connectors to TCM and ECM. 2) Connect the Subaru Select Monitor to data link connector. 3) Start the engine, and turn the Subaru Select monitor switch to ON. 4) Warm-up the engine until the engine coolant temperature is above 80°C (176°F). 5) Engine idling. 6) Read the data of intake manifold pressure signal using Subaru Select Monitor. • Display shows the intake manifold pressure signal value sent from ECM.	Is the value between 0.4 and 1.6 V?	Even if the AT OIL TEMP warning lights up, the circuit has returned to a normal condition at this time. A temporary poor contact of the connector or harness may be the cause. Repair harness or connector in the TCM and ECM.	Go to step 7.
7 CHECK POOR CONTACT.	Is there poor contact in intake manifold pressure signal circuit?	Repair poor contact.	Replace the TCM. <Ref. to AT-45, Transmission Control Module (TCM).>

813 : PREPARE SUBARU SELECT MONITOR.

CHECK : *Do you have a Subaru Select Monitor?*

YES : Go to step 815.

NO : Go to step 814.

814 : CHECK INPUT SIGNAL FOR TCM.

- 1) Connect connectors to TCM and ECM.
- 2) Start the engine, and warm-up the transmission until ATF temperature is above 80°C (176°F).

NOTE:

If ambient temperature is below 0°C (32°F), drive the vehicle until the ATF reaches its operating temperature.

- 3) Engine idling.
- 4) Measure voltage between TCM connectors.

Connector & terminal

(B55) No. 20 (+) — No. 19 (-):

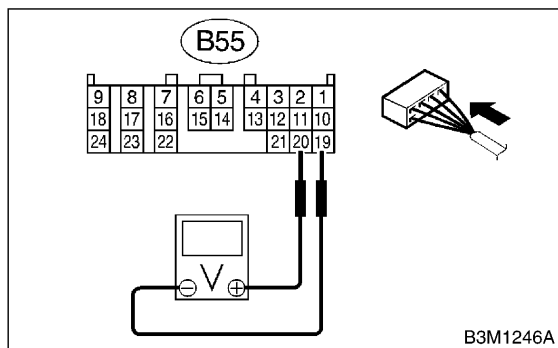

CHECK : *Is the voltage between 0.4 and 1.6 V?*

YES : Even if "AT OIL TEMP" lights up, the circuit has returned to a normal condition at this time. A temporary poor contact of the connector or harness may be the cause. Repair harness or connector in the TCM and ECM.

NO : Go to step 816.

815 : CHECK INPUT SIGNAL FOR TCM USING SUBARU SELECT MONITOR.

- 1) Connect connectors to TCM and ECM.
- 2) Turn ignition switch to OFF.
- 3) Connect Subaru Select Monitor to data link connector.

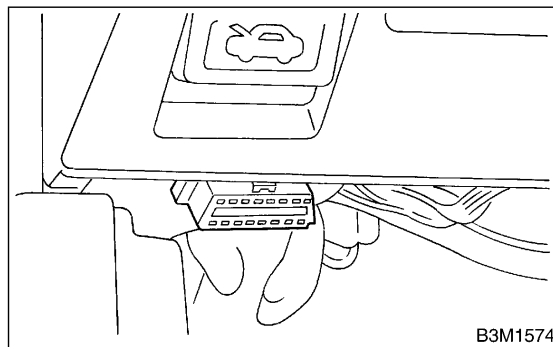

- 4) Start the engine, and turn Subaru Select monitor switch to ON.
- 5) Warm-up the engine until engine coolant temperature is above 80°C (176°F).
- 6) Engine idling.
- 7) Read data of intake manifold pressure signal using Subaru Select Monitor.

● Display shows intake manifold pressure signal value sent from ECM.

CHECK : *Is the value between 0.4 and 1.6 V?*

YES : Even if "AT OIL TEMP" lights up, the circuit has returned to a normal condition at this time. A temporary poor contact of the connector or harness may be the cause. Repair harness or connector in the TCM and ECM.

NO : Go to step 816.

816 : CHECK POOR CONTACT.

CHECK : *Is there poor contact in intake manifold pressure signal circuit?*

YES : Repair poor contact.

NO : Replace TCM. <Ref. to 3-2 [W23A0].>

DIAGNOSTIC PROCEDURE WITH TROUBLE CODE

Automatic Transmission (DIAGNOSTICS)

No.	Step	Check	Yes	No
3	<p>CHECK HARNESS CONNECTOR BETWEEN TCM AND ECM. Measure resistance of harness between TCM connector and chassis ground.</p> <p>Connector & terminal WITHOUT VDC SYSTEM (B55) No. 20 Chassis ground: WITH VDC SYSTEM (B54) No. 10 Chassis ground:</p>	Is the resistance more than 1 MΩ?	Go to step 4.	Repair short circuit in harness between TCM and ECM connector.
4	<p>PREPARE SUBARU SELECT MONITOR.</p>	Do you have a Subaru Select Monitor?	Go to step 6.	Go to step 5.
5	<p>CHECK INPUT SIGNAL FOR TCM. 1) Connect connectors to TCM and ECM. 2) Start the engine, and warm-up the transmission until ATF temperature is above 80 C (176 F). NOTE: If ambient temperature is below 0 C (32 F), drive the vehicle until the ATF reaches its operating temperature. 3) Engine idling. 4) Measure voltage between TCM connector and chassis ground.</p> <p>Connector & terminal 2.5 ℓ ENGINE MODEL (B55) No. 20 (+) Chassis ground (-): 3.0 ℓ ENGINE MODEL WITHOUT VDC SYSTEM (B55) No. 20 (+) Chassis ground (-): 3.0 ℓ ENGINE MODEL WITH VDC SYSTEM (B54) No. 10 (+) Chassis ground (-):</p>	Is the voltage between 0.4 and 1.6 V?	Even if AT OIL TEMP lights up, the circuit has returned to a normal condition at this time. A temporary poor contact of the connector or harness may be the cause. Repair harness or connector in the TCM and ECM.	Go to step 7.
6	<p>CHECK INPUT SIGNAL FOR TCM USING SUBARU SELECT MONITOR. 1) Connect connectors to TCM and ECM. 2) Turn ignition switch to OFF. 3) Connect Subaru Select Monitor to data link connector. 4) Start the engine, and turn Subaru Select monitor switch to ON. 5) Warm-up the engine until engine coolant temperature is above 80 C (176 F). 6) Engine idling. 7) Read data of intake manifold pressure signal using Subaru Select Monitor. ● Display shows intake manifold pressure signal value sent from ECM.</p>	Is the value between 0.4 and 1.6 V?	Even if AT OIL TEMP lights up, the circuit has returned to a normal condition at this time. A temporary poor contact of the connector or harness may be the cause. Repair harness or connector in the TCM and ECM.	Go to step 7.
7	<p>CHECK POOR CONTACT.</p>	Is there poor contact in intake manifold pressure signal circuit?	Repair poor contact.	Replace TCM. <Ref. to AT-42 Transmission Control Module (TCM).>

DIAGNOSTICS CHART WITH DIAGNOSIS CONNECTOR

ABS (DIAGNOSTICS)

No.	Step	Check	Yes	No
1	CHECK ALL FOUR WHEELS FOR FREE TURNING.	Have the wheels been turned freely such as when the vehicle is lifted up, or operated on a rolling road?	The ABS is normal. Erase the trouble code.	Go to step 2.
2	CHECK SPECIFICATIONS OF ABSCM&H/U. Check specifications of the mark to the ABSCM&H/U. C5: AT (Except OUTBACK) C6: MT (Except OUTBACK) CE: AT (OUTBACK) CF: MT (OUTBACK)	Does the vehicle specification and the ABSCM&H/U specification match?	Go to step 3.	Replace ABSCM&H/U. <Ref. to ABS-7 ABS Control Module and Hydraulic Control Unit (ABSCM&H/U).> CAUTION: Be sure to turn ignition switch to OFF when removing ABSCM&H/U.
3	CHECK INPUT VOLTAGE OF G SENSOR. 1) Turn ignition switch to OFF. 2) Remove console box. 3) Disconnect G sensor from body. (Do not disconnect connector.) 4) Turn ignition switch to ON. 5) Measure voltage between G sensor connector terminals. Connector & terminal (R70) No. 1 (+) No. 3 (-):	Is the voltage between 4.75 and 5.25 V?	Go to step 4.	Repair harness/connector between G sensor and ABSCM&H/U.
4	CHECK OPEN CIRCUIT IN G SENSOR OUTPUT HARNESS AND GROUND HARNESS. 1) Turn ignition switch to OFF. 2) Disconnect connector from ABSCM&H/U. 3) Measure resistance between ABSCM&H/U connector terminals. Connector & terminal (F49) No. 6 No. 28:	Is the resistance between 4.3 and 4.9 kΩ?	Go to step 5.	Repair harness/connector between G sensor and ABSCM&H/U.
5	CHECK GROUND SHORT IN G SENSOR OUTPUT HARNESS. 1) Disconnect connector from G sensor. 2) Measure resistance between ABSCM&H/U connector and chassis ground. Connector & terminal (F49) No. 6 Chassis ground:	Is the resistance more than 1 MΩ?	Go to step 6.	Repair harness between G sensor and ABSCM&H/U.
6	CHECK BATTERY SHORT OF HARNESS. Measure voltage between ABSCM&H/U connector and chassis ground. Connector & terminal (F49) No. 6 (+) Chassis ground (-):	Is the voltage less than 1 V?	Go to step 7.	Repair harness between G sensor and ABSCM&H/U.
7	CHECK BATTERY SHORT OF HARNESS. 1) Turn ignition switch to ON. 2) Measure voltage between ABSCM&H/U connector and chassis ground. Connector & terminal (F49) No. 6 (+) Chassis ground (-):	Is the voltage less than 1 V?	Go to step 8.	Repair harness between G sensor and ABSCM&H/U.

DIAGNOSTICS CHART WITH TROUBLE CODE

Cruise Control System (DIAGNOSTICS)

7. Diagnostics Chart with Trouble Code S003620

A: LIST OF DIAGNOSTIC TROUBLE CODE S003620E40

Diagnostic trouble code	Item	Contents of diagnosis	Reference
21	Inner relay is seized.	Cruise control module inner relay is seized when main switch is OFF.	<Ref. to CC-30 DIAGNOSTIC TROUBLE CODE 21, 24, 25 AND 2A - CRUISE CONTROL MODULE BUILT-IN RELAY, CPU RAM -, Diagnostics Chart with Trouble Code.>
22	Vehicle speed sensor	Vehicle speed signal changes more than 10 km/h (6 MPH) within 350 ms.	<Ref. to CC-31 DIAGNOSTIC TROUBLE CODE 22 - VEHICLE SPEED SENSOR -, Diagnostics Chart with Trouble Code.>
24	Cruise control module is abnormal.	Two vehicle speed values stored in cruise control module memory are not the same.	<Ref. to CC-30 DIAGNOSTIC TROUBLE CODE 21, 24, 25 AND 2A - CRUISE CONTROL MODULE BUILT-IN RELAY, CPU RAM -, Diagnostics Chart with Trouble Code.>
25	Cruise control module is abnormal.	Two output values stored in cruise control module memory are not the same.	<Ref. to CC-30 DIAGNOSTIC TROUBLE CODE 21, 24, 25 AND 2A - CRUISE CONTROL MODULE BUILT-IN RELAY, CPU RAM -, Diagnostics Chart with Trouble Code.>
28	Wiring harness opened.	Open wiring harness circuit is detected via control module relay when main switch is ON.	<Ref. to CC-34 DIAGNOSTIC TROUBLE CODE 28 - WIRING HARNESS OPENED. -, Diagnostics Chart with Trouble Code.>
35	Motor drive system is abnormal.	<ul style="list-style-type: none"> ● Motor output circuit is open or shorted. ● Motor drive circuit is open or shorted. 	<Ref. to CC-35 DIAGNOSTIC TROUBLE CODE 35 and 36 - ACTUATOR MOTOR - Diagnostics Chart with Trouble Code.>
36	Trouble of Motor.	Motor turning speed is low.	<Ref. to CC-35 DIAGNOSTIC TROUBLE CODE 35 and 36 - ACTUATOR MOTOR - Diagnostics Chart with Trouble Code.>
37	Motor clutch drive system is abnormal.	<ul style="list-style-type: none"> ● Motor clutch output circuit is open or shorted. ● Motor clutch drive circuit is open or shorted. 	<Ref. to CC-37 DIAGNOSTIC TROUBLE CODE 37 - ACTUATOR MOTOR CLUTCH -, Diagnostics Chart with Trouble Code.>
38	Motor drive shaft does not engage properly.	Motor drive gear engagement is not properly adjusted.	<Ref. to CC-39 DIAGNOSTIC TROUBLE CODE 38 - MOTOR DRIVE SHAFT DOES NOT ENGAGE PROPERLY. -, Diagnostics Chart with Trouble Code.>
39	Motor is overloaded.	Current flows through motor more frequently than under normal conditions.	<Ref. to CC-40 DIAGNOSTIC TROUBLE CODE 39 - MOTOR IS OVERLOADED. -, Diagnostics Chart with Trouble Code.>
2A	Cruise control module is abnormal.	Cruise control module self-diagnosis function senses abnormality.	<Ref. to CC-30 DIAGNOSTIC TROUBLE CODE 21, 24, 25 AND 2A - CRUISE CONTROL MODULE BUILT-IN RELAY, CPU RAM -, Diagnostics Chart with Trouble Code.>

B: DIAGNOSTIC TROUBLE CODE 21, 24, 25 AND 2A — CRUISE CONTROL MODULE BUILT-IN RELAY, CPU RAM — S003620F29

DIAGNOSIS:

- Poor welding of built-in relay of cruise control module.
- Failure of built-in CPU RAM of cruise control module.

DIAGNOSTICS CHART WITH TROUBLE CODE

Cruise Control System (DIAGNOSTICS)

E: DIAGNOSTIC TROUBLE CODE 35 and 36 — ACTUATOR MOTOR —

S003620F32

DIAGNOSIS:

Open or poor contact of cruise control actuator motor.

WIRING DIAGRAM:

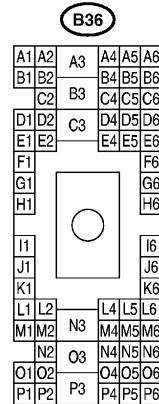
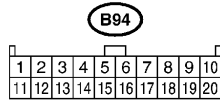
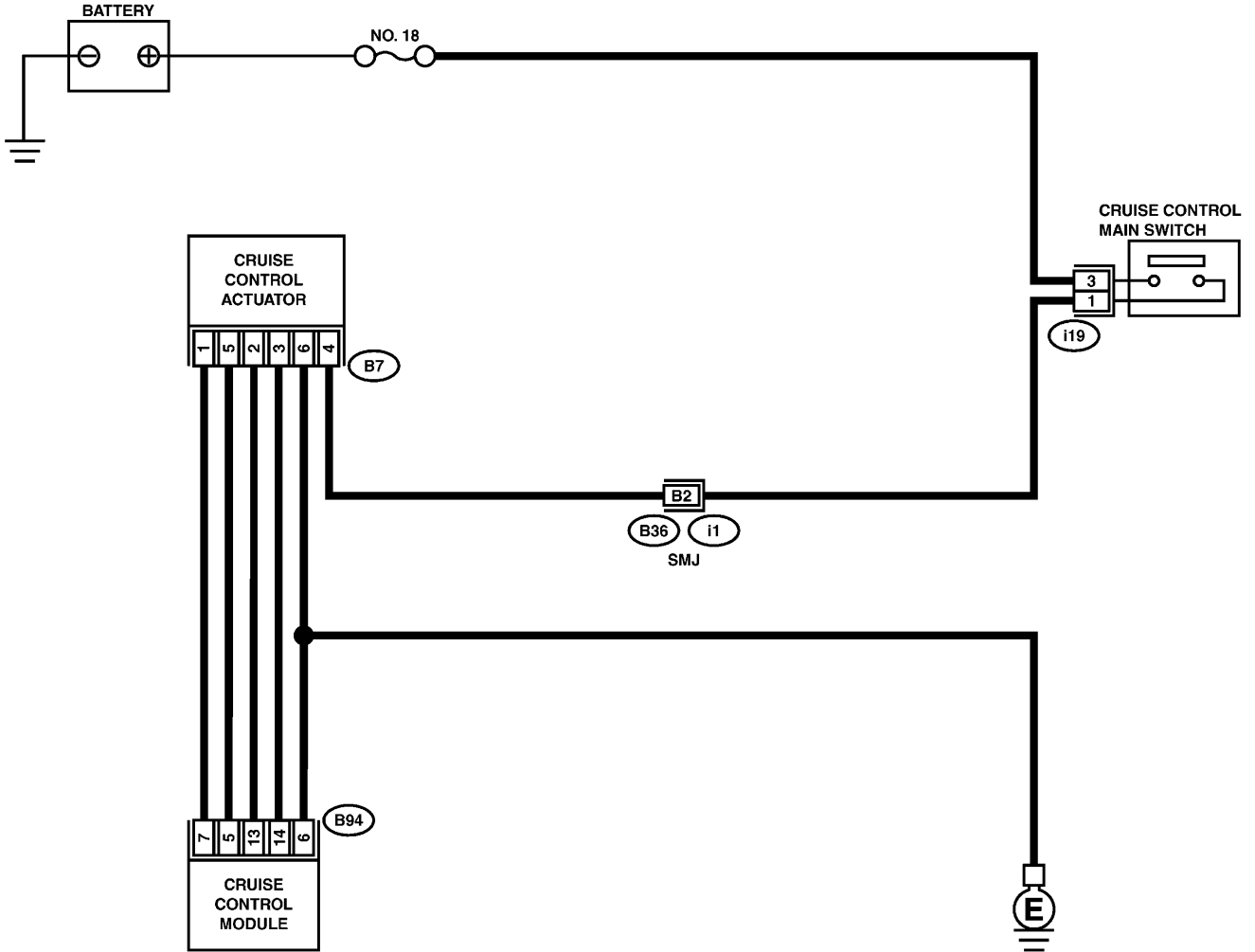

B6M1529

DIAGNOSTIC PROCEDURE WITH DIAGNOSTIC TROUBLE CODE (DTC)

Automatic Transmission (Diagnostics)

No.	Step	Check	Yes	No
3	<p>CHECK HARNESS CONNECTOR BETWEEN TCM AND ECM. Measure the resistance of harness between TCM connector and chassis ground.</p> <p>Connector & terminal <i>Without VDC system</i> (B55) No. 20 Chassis ground: <i>With VDC system</i> (B54) No. 10 Chassis ground:</p>	Is the resistance more than 1 MΩ?	Go to step 4.	Repair short circuit in harness between TCM and ECM connector.
4	<p>PREPARE SUBARU SELECT MONITOR.</p>	Do you have a Subaru Select Monitor?	Go to step 6.	Go to step 5.
5	<p>CHECK INPUT SIGNAL FOR TCM. 1) Connect the connectors to TCM and ECM. 2) Start the engine, and warm-up the transmission until the ATF temperature is above 80 C (176 F). NOTE: If ambient temperature is below 0 C (32 F), drive the vehicle until the ATF reaches its operating temperature. 3) Engine idling. 4) Measure the voltage between TCM connector and chassis ground.</p> <p>Connector & terminal <i>Without VDC system</i> (B55) No. 20 (+) Chassis ground (-): <i>With VDC system</i> (B54) No. 10 (+) Chassis ground (-):</p>	Is the voltage between 0.4 and 1.6 V?	Even if the AT OIL TEMP warning lights up, the circuit has returned to a normal condition at this time. A temporary poor contact of the connector or harness may be the cause. Repair harness or connector in the TCM and ECM.	Go to step 7.
6	<p>CHECK INPUT SIGNAL FOR TCM USING SUBARU SELECT MONITOR. 1) Connect the connectors to TCM and ECM. 2) Connect the Subaru Select Monitor to data link connector. 3) Start the engine, and turn the Subaru Select monitor switch to ON. 4) Warm-up the engine until the engine coolant temperature is above 80 C (176 F). 5) Engine idling. 6) Read the data of intake manifold pressure signal using Subaru Select Monitor. ● Display shows the intake manifold pressure signal value sent from ECM.</p>	Is the value between 0.4 and 1.6 V?	Even if the AT OIL TEMP warning lights up, the circuit has returned to a normal condition at this time. A temporary poor contact of the connector or harness may be the cause. Repair harness or connector in the TCM and ECM.	Go to step 7.
7	<p>CHECK POOR CONTACT.</p>	Is there poor contact in intake manifold pressure signal circuit?	Repair poor contact.	Replace the TCM. <Ref. to AT-49, Transmission Control Module (TCM).>

DIAGNOSTICS CHART WITH DIAGNOSIS CONNECTOR

ABS (Diagnostics)

No.	Step	Check	Yes	No
1	CHECK ALL FOUR WHEELS FOR FREE TURNING.	Have the wheels been turned freely such as when the vehicle is lifted up, or operated on a rolling road?	The ABS is normal. Erase the diagnostic trouble code.	Go to step 2.
2	CHECK SPECIFICATIONS OF ABSCM&H/U. Check specifications of the mark to the ABSCM&H/U. CG: AT (Except OUTBACK) CH: MT (Except OUTBACK) CI: AT (OUTBACK) CJ: MT (OUTBACK)	Does the vehicle specification and the ABSCM&H/U specification match?	Go to step 3.	Replace ABSCM&H/U. <Ref. to ABS-7, ABS Control Module and Hydraulic Control Unit (ABSCM&H/U).> CAUTION: Be sure to turn ignition switch to OFF when removing ABSCM&H/U.
3	CHECK INPUT VOLTAGE OF G SENSOR. 1) Turn ignition switch to OFF. 2) Remove console box. 3) Disconnect G sensor from body. (Do not disconnect connector.) 4) Turn ignition switch to ON. 5) Measure voltage between G sensor connector terminals. Connector & terminal (R70) No. 1 (+) No. 3 (-):	Is the voltage between 4.75 and 5.25 V?	Go to step 4.	Repair harness/connector between G sensor and ABSCM&H/U.
4	CHECK OPEN CIRCUIT IN G SENSOR OUTPUT HARNESS AND GROUND HARNESS. 1) Turn ignition switch to OFF. 2) Disconnect connector from ABSCM&H/U. 3) Measure resistance between ABSCM&H/U connector terminals. Connector & terminal (F49) No. 6 No. 28:	Is the resistance between 4.3 and 4.9 k Ω ?	Go to step 5.	Repair harness/connector between G sensor and ABSCM&H/U.
5	CHECK GROUND SHORT IN G SENSOR OUTPUT HARNESS. 1) Disconnect connector from G sensor. 2) Measure resistance between ABSCM&H/U connector and chassis ground. Connector & terminal (F49) No. 6 Chassis ground:	Is the resistance more than 1 M Ω ?	Go to step 6.	Repair harness between G sensor and ABSCM&H/U.
6	CHECK BATTERY SHORT OF HARNESS. Measure voltage between ABSCM&H/U connector and chassis ground. Connector & terminal (F49) No. 6 (+) Chassis ground (-):	Is the voltage less than 1 V?	Go to step 7.	Repair harness between G sensor and ABSCM&H/U.
7	CHECK BATTERY SHORT OF HARNESS. 1) Turn ignition switch to ON. 2) Measure voltage between ABSCM&H/U connector and chassis ground. Connector & terminal (F49) No. 6 (+) Chassis ground (-):	Is the voltage less than 1 V?	Go to step 8.	Repair harness between G sensor and ABSCM&H/U.

SPARK PLUGS

5. Spark Plugs SA07683

A: REPLACEMENT SA07683A20

1. 2.5 L MODEL SA07683A2001

- 1) Disconnect battery ground cable.
- 2) Remove intake duct and intake chamber.
- 3) Remove washer tank and put it aside.
- 4) Disconnect spark plug cord.
- 5) Remove spark plug with a plug-wrench.

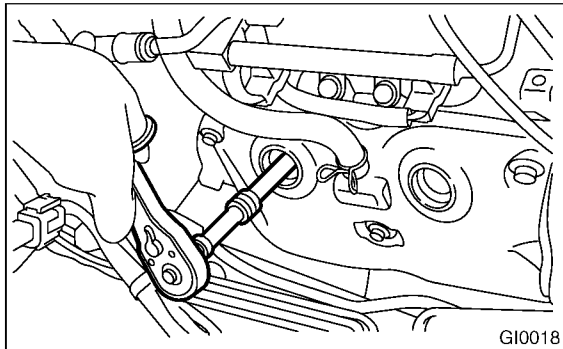

- 6) Set new spark plug.

Recommended spark plug:

CHAMPION RC10YC4

NGK BKR5E-11

NGK BKR6E-11

Spark plug gap

1.0 — 1.1 mm (0.039 — 0.043 in)

- 7) Tighten spark plug lightly with hand, and then secure with a plug-wrench to the specified torque.

Tightening torque:

20.6 N·m (2.10 kgf-m, 15.19 ft-lb)

NOTE:

- Be sure to place the gasket between the cylinder head and spark plug.
- If torque wrench is not available, tighten spark plug until gasket contacts cylinder head; then tighten further 1/4 to 1/2 turns.

2. 3.0 L MODEL SA07683A2002

- 1) Disconnect battery cables and then remove battery and battery carrier.
- 2) Remove washer tank and put it aside.
- 3) Remove air cleaner lower case.
- 4) Disconnect connector from ignition coil.

- 5) Remove ignition coil.

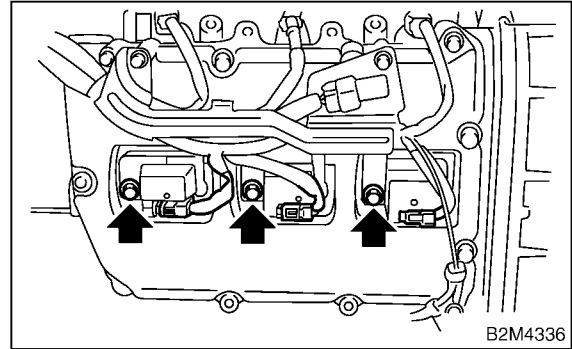

- 6) Remove spark plug with a spark plug socket.

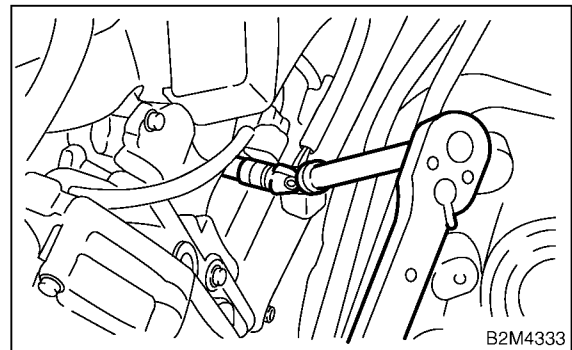

- 7) Set new spark plug.

Recommended spark plug:

NGK PLFR 6A-11

- 8) Tighten spark plug lightly with hand, and then secure with a plug-wrench to the specified torque.

Tightening torque:

21 N·m (2.1 kgf-m, 15 ft-lb)

- 9) Tighten ignition coil.

Tightening torque:

16 N·m (1.6 kgf-m, 12 ft-lb)

NOTE:

- Be sure to place the gasket between the cylinder head and spark plug.
- If torque wrench is not available, tighten spark plug until gasket contacts cylinder head; then tighten further 1/4 to 1/2 turn.

16. Front & Rear Differential Oil

SA07693

A: REPLACEMENT

SA07693A20

1. FRONT DIFFERENTIAL (MANUAL TRANSMISSION)

SA07693A2001

For M/T vehicle, manual transmission oil works as differential oil to lubricate differential. Refer to "Transmission Oil". <Ref. to PM-21, MANUAL TRANSMISSION, REPLACEMENT, Transmission Oil.>

2. FRONT DIFFERENTIAL (AUTOMATIC TRANSMISSION)

SA07693A2002

1) Drain differential gear oil by removing drain plug after allowing the engine to cool for 3 to 4 hours.

NOTE:

Before starting work, cool off the engine well.

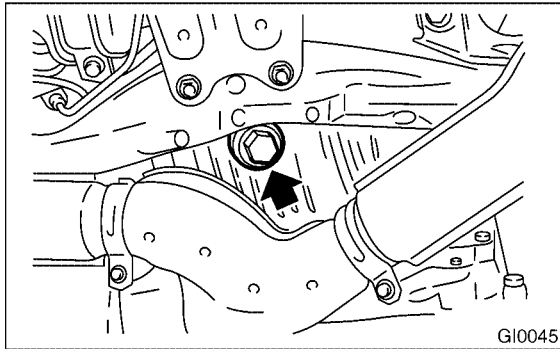

2) Reinstall drain plug after draining differential gear oil and tighten it to the specified torque.

Tightening torque:

44 N·m (4.5 kgf-m, 32.5 ft-lb)

NOTE:

- Be sure to place a gasket between the transmission case and drain plug.
- Replace the gasket with a new one.
- Each oil manufacturer has its base oil and additives. Thus, do not mix two or more brands.

3) Fill differential gear oil through the oil level gauge hole up to the upper point of level gauge.

Differential gear oil capacity:

1.1 — 1.3 l (1.2 — 1.4 US qt, 1.0 — 1.1 Imp qt)

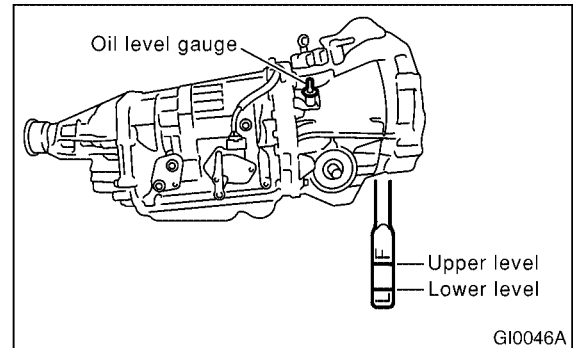

3. REAR DIFFERENTIAL

SA07693A2003

● **L and BRIGHTON AT model**

- 1) Drain oil by removing drain plug.
- 2) Remove filler plug for quicker draining.
- 3) Replace drain plug gasket with a new one.
- 4) Tighten drain plug to the specified torque.

Tightening torque:

34 N·m (3.5 kgf-m, 25.3 ft-lb)

5) After installing drain plug, fill oil fully up to the mouth of filler plug.

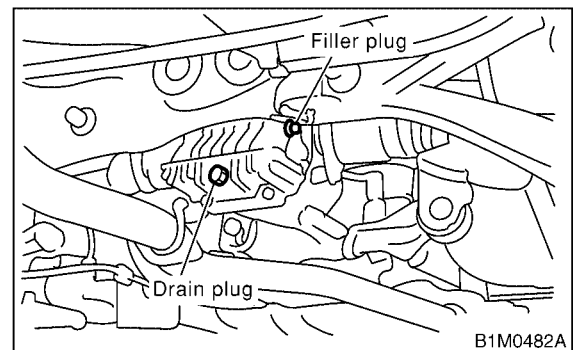

Oil capacity:

0.9 l (1.0 US qt, 0.8 Imp qt)

- 6) Replace filler plug gasket with a new one.
- 7) Install filler plug onto rear differential gear case.

Tightening torque:

34 N·m (3.5 kgf-m, 25.3 ft-lb)

FRONT & REAR DIFFERENTIAL OIL

Periodic Maintenance Services

● Except L and BRIGHTON AT model

- 1) Drain oil by removing drain plug.
- 2) Remove filler plug for quicker draining.
- 3) Tighten drain plug after draining oil.

NOTE:

Apply fluid packing to drain plug threads before installation.

Fluid packing:

Three Bond 1105

Tightening torque:

49 N·m (5.0 kgf-m, 36.2 ft-lb)

- 4) After installing drain plug onto rear differential gear case firmly, fill oil up fully to the mouth of filler plug.

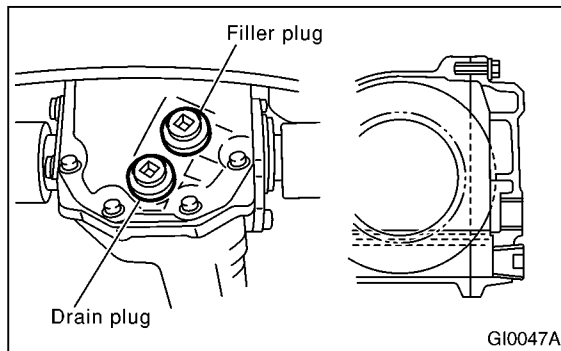

Oil capacity:

0.8 ℓ (0.8 US qt, 0.7 Imp qt)

NOTE:

Each oil manufacturer has its base oil and additives. Thus, do not mix two or more brands.

- 5) Install filler plug onto rear differential gear case firmly.

NOTE:

Apply fluid packing to filler plug before installation.

Fluid packing:

Three Bond 1105

Tightening torque:

49 N·m (5.0 kgf-m, 36.2 ft-lb)

ENGINE CONTROL MODULE (ECM) I/O SIGNAL

Engine (DIAGNOSTICS)

Content	Con- nector No.	Termi- nal No.	Signal (V)		Note
			Ignition SW ON (Engine OFF)	Engine ON (Idling)	
GND (power supply)	B134	22	0	0	—
	B136	17	0	0	—
GND (control systems)	B134	7	0	0	—
		15	0	0	—
GND (oxygen sensor heater LH)	1	B137	21	0	—
	2	B137	31	0	—
GND (oxygen sensor heater RH)	1	B137	9	0	—
	2	B137	8	0	—

B: MEASUREMENT S048526A14

Measure input/output signal voltage.

1. WAVEFORM S048526A1401

