

CLEARANCE LIGHT AND ILLUMINATION LIGHT SYSTEM

Wiring System

24. Clearance Light and Illumination Light System

S903489

A: SCHEMATIC

S903489A21

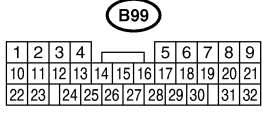
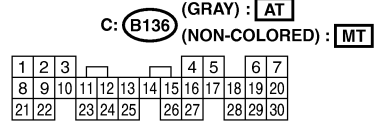
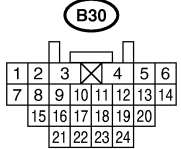
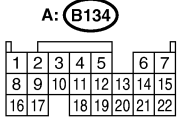
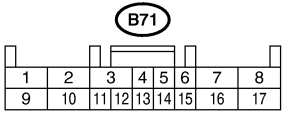
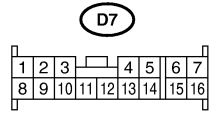
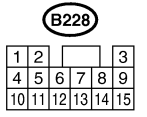
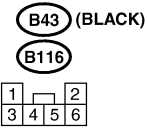
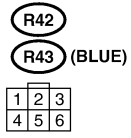
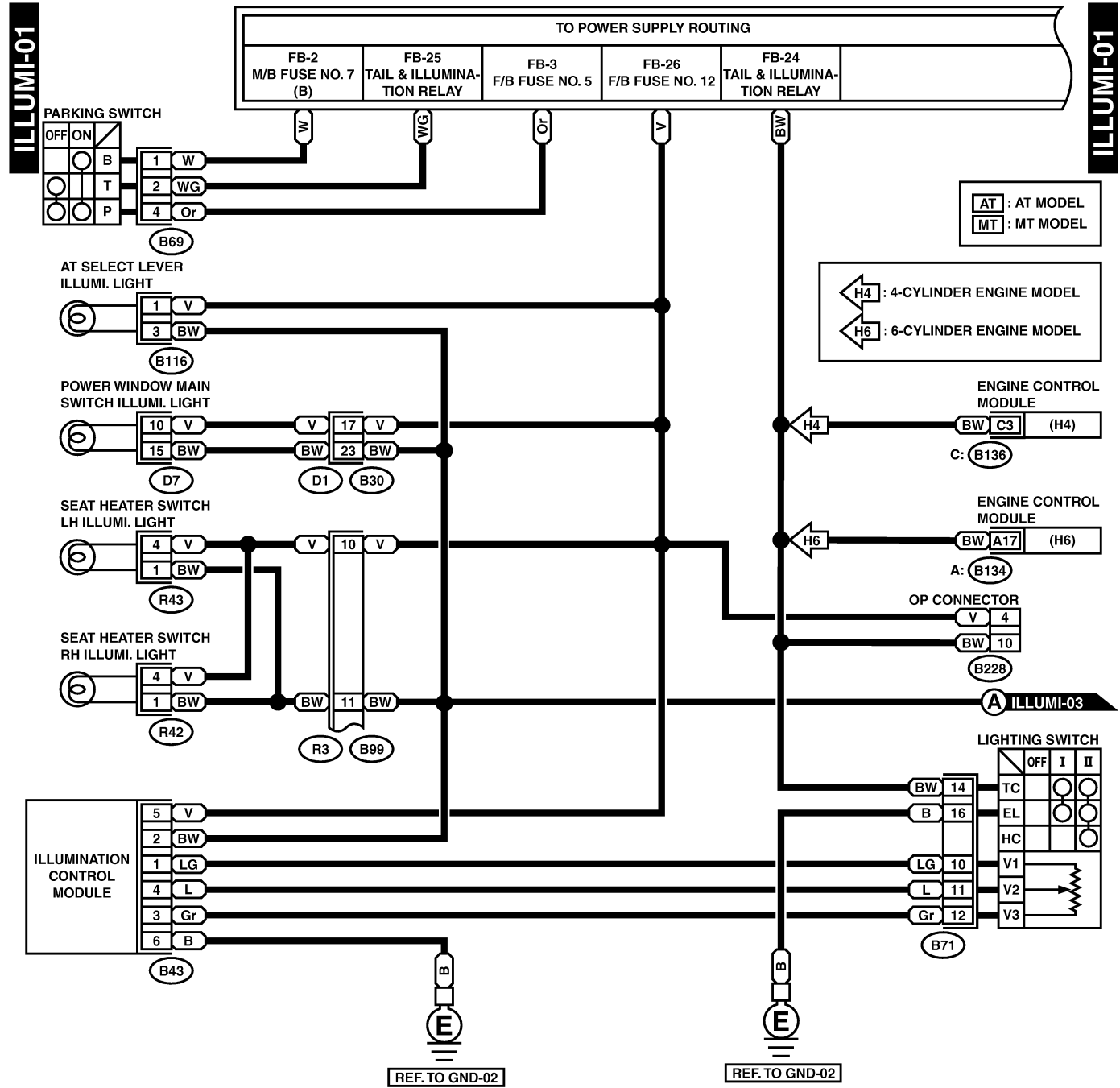

CLEARANCE LIGHT AND ILLUMINATION LIGHT SYSTEM

Wiring System

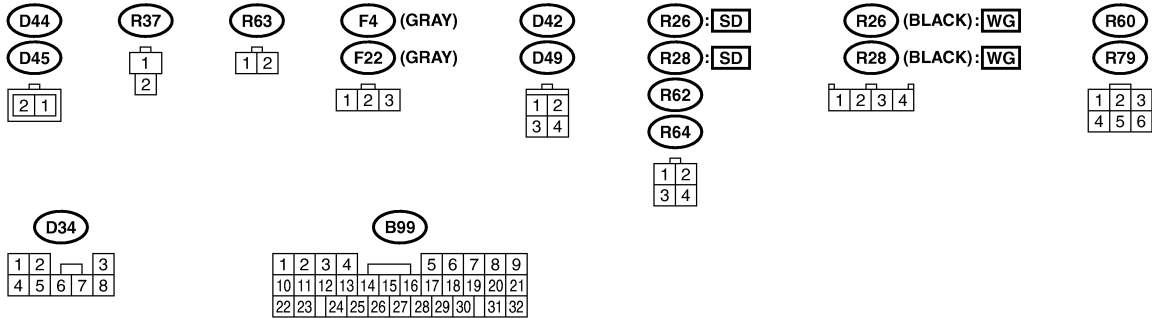
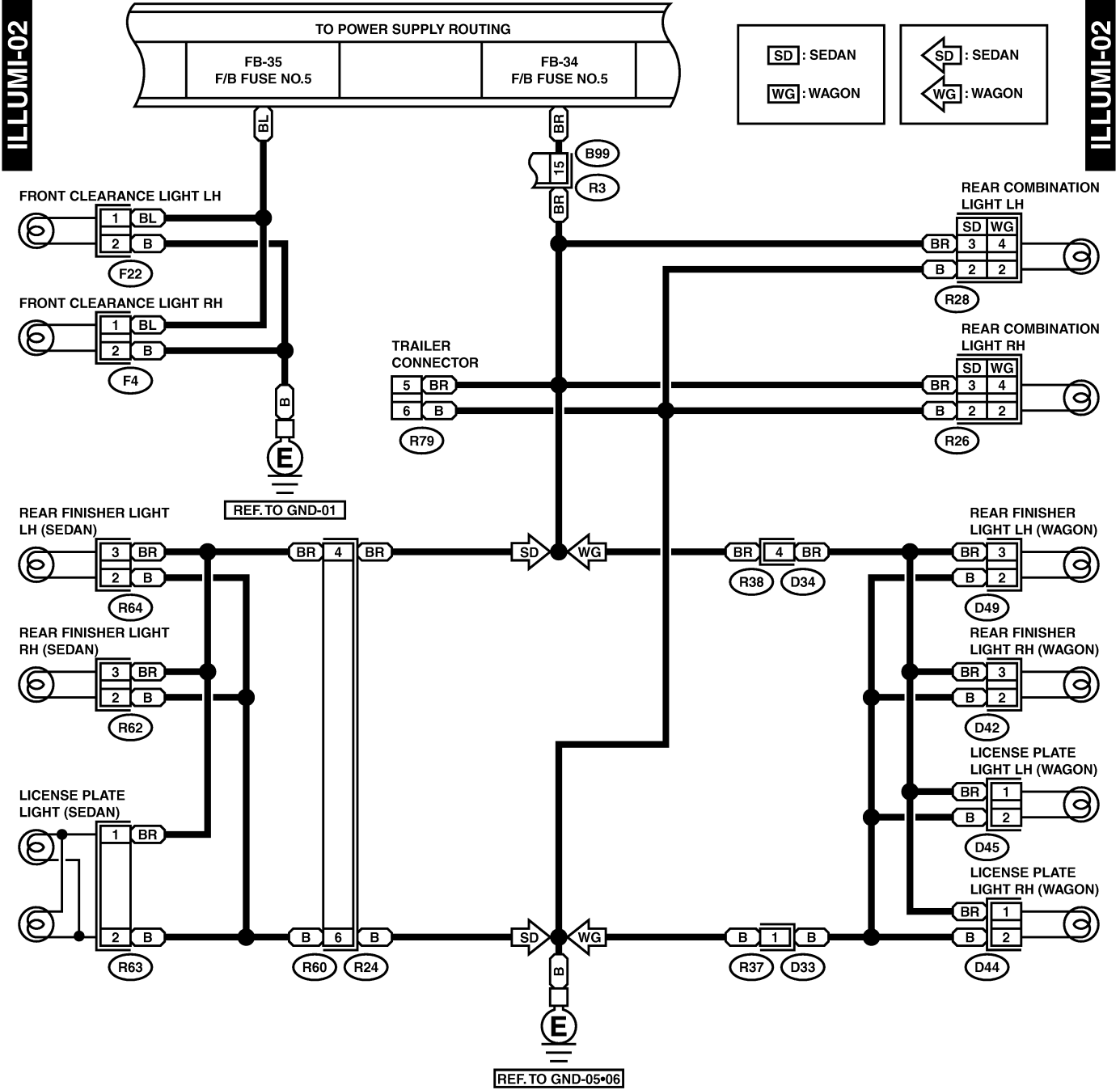

CLEARANCE LIGHT AND ILLUMINATION LIGHT SYSTEM

Wiring System

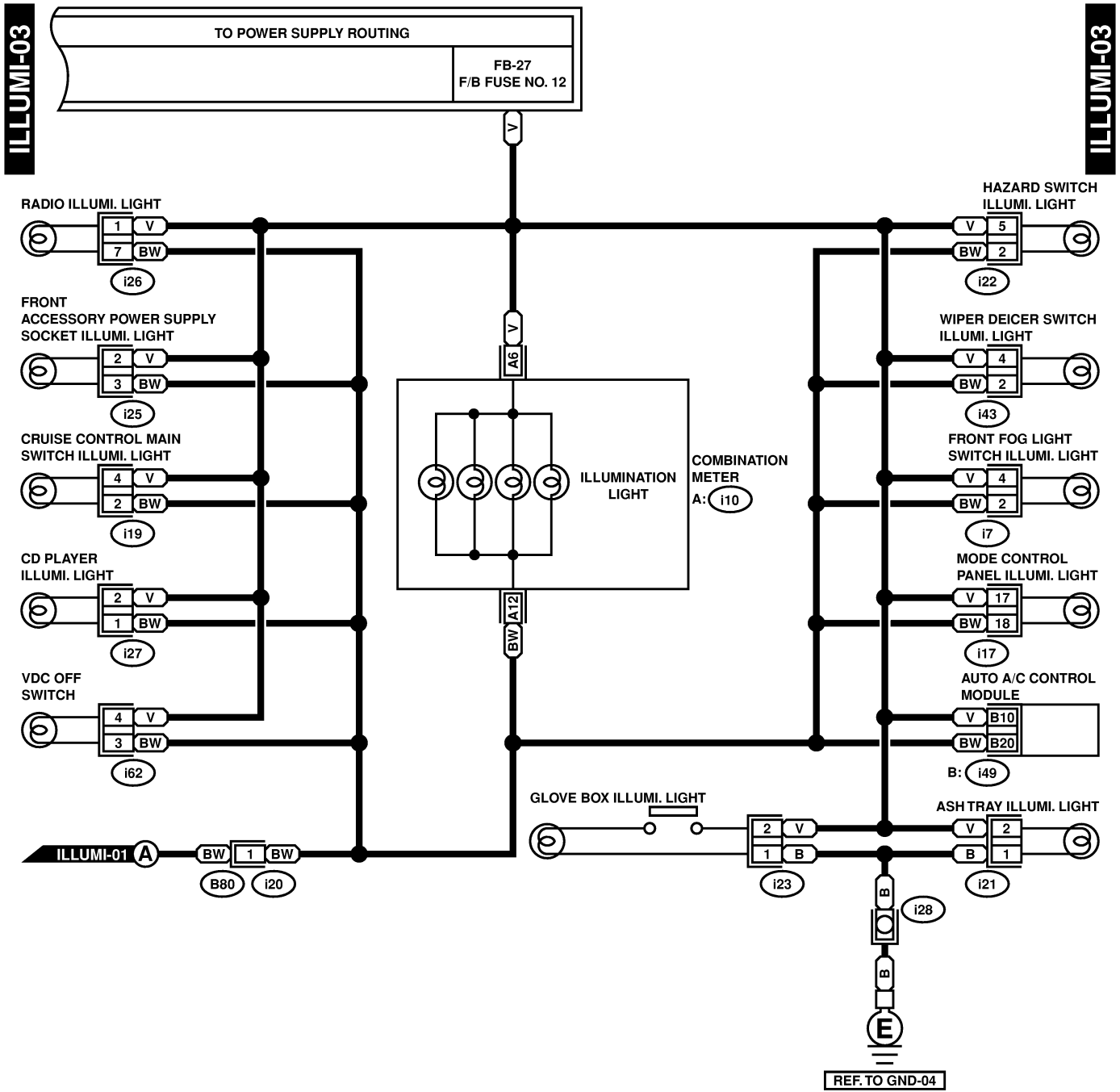

REF. TO GND-04

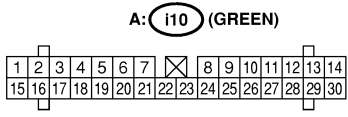
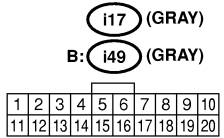
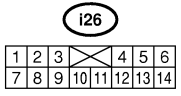
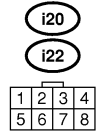
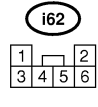
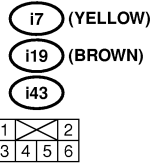
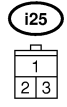
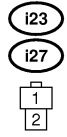
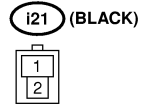

CLEARANCE LIGHT AND ILLUMINATION LIGHT SYSTEM

Wiring System

MEMO: