

GENERAL DESCRIPTION

AIRBAG SYSTEM

1. General Description

A: COMPONENT

1. SRS AIRBAG

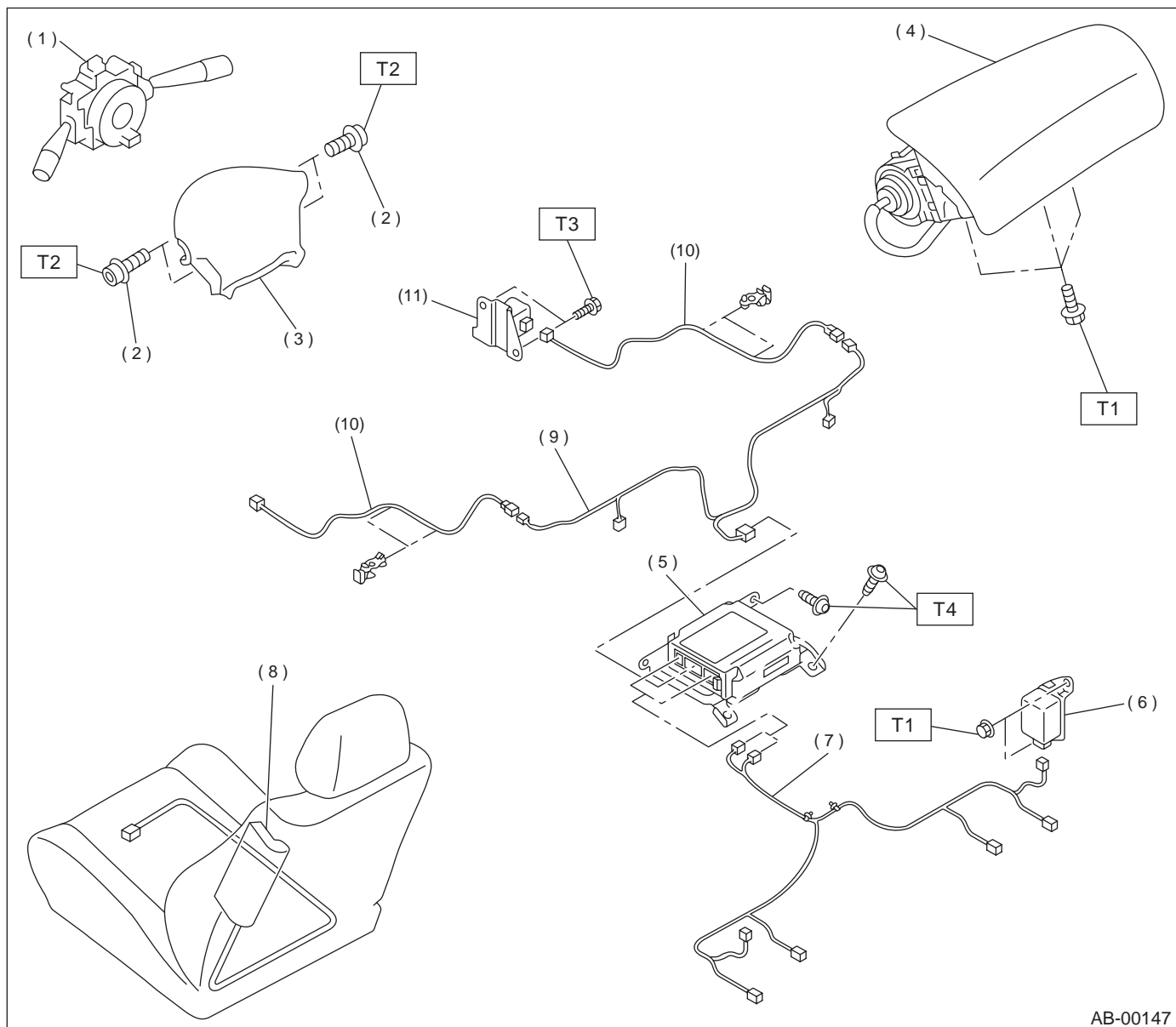

- | | |
|---|-------------------------------|
| (1) Combination switch ASSY with roll connector | (6) Side airbag sensor |
| (2) TORX® bolt T30 | (7) Side airbag harness |
| (3) Airbag module ASSY (Driver) | (8) Side airbag module |
| (4) Airbag module ASSY (Passenger) | (9) Airbag main harness |
| (5) Airbag control module | (10) Front sub sensor harness |
| | (11) Front sub sensor |

Tightening torque: N·m (kgf-m, ft-lb)

T1: 7.4 (0.75, 5.4)

T2: 10 (1.0, 7.2)

T3: 20 (2.0, 14.5)

T4: 25 (2.5, 18.1)

GENERAL DESCRIPTION

AIRBAG SYSTEM

B: CAUTION

- When servicing a vehicle, be sure to turn the ignition switch OFF, disconnect the ground cable from the battery, and wait for more than 20 seconds before starting work.
- The airbag system is fitted with a backup power source. If the airbag system is serviced within 20 seconds after the ground cable is disconnected, it may inflate.

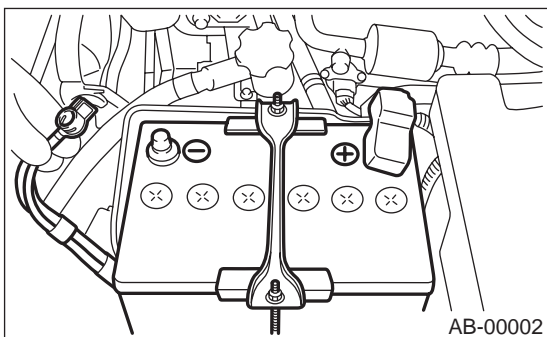

- If sensors, airbag module, airbag control module, pretensioner, and harness are deformed or damaged, replace them with new genuine parts.

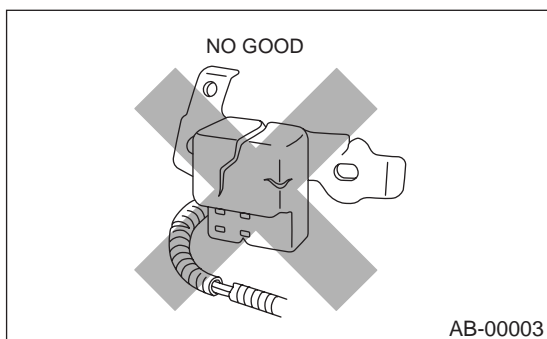

- When checking the system, be sure to use a digital circuit tester. Use of an analog circuit tester may cause the airbag to activate erroneously.

- When checking, use a test harness. Do not directly apply the tester probe to any connector terminal of the airbag.

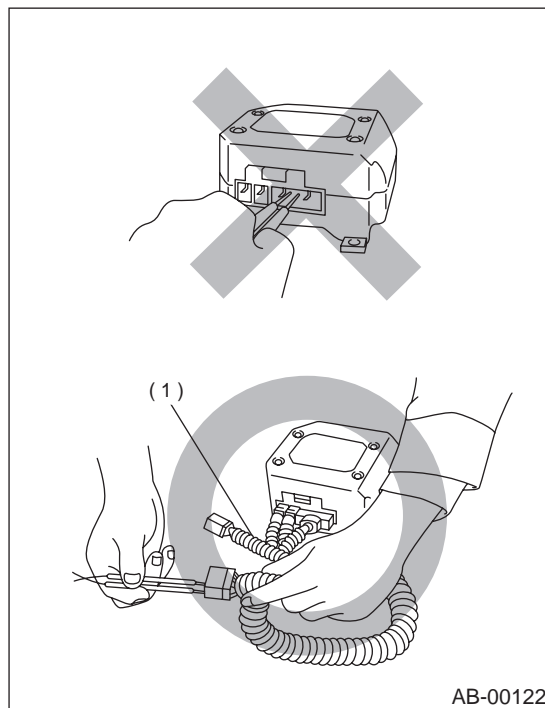
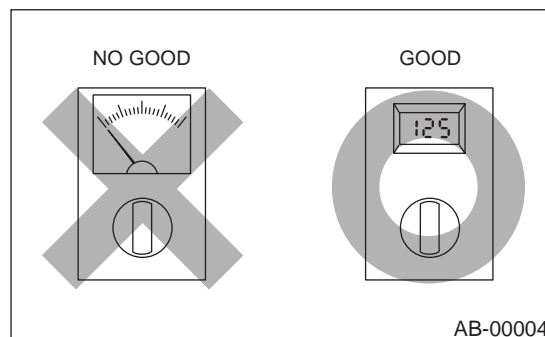

(1) Test harness

- Do not check continuity of either of the airbag modules for driver, passenger or side, or pretensioner.

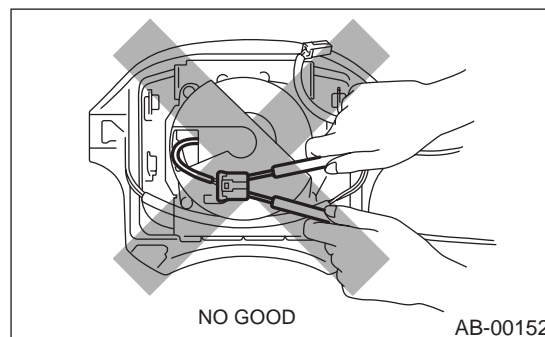

GENERAL DESCRIPTION

AIRBAG SYSTEM

- Do not drop the airbag modulator parts, subject them to high temperature over 93°C (199°F), or let water, oil, or grease get on them; otherwise, the internal parts may be damaged and reliability greatly lowered.

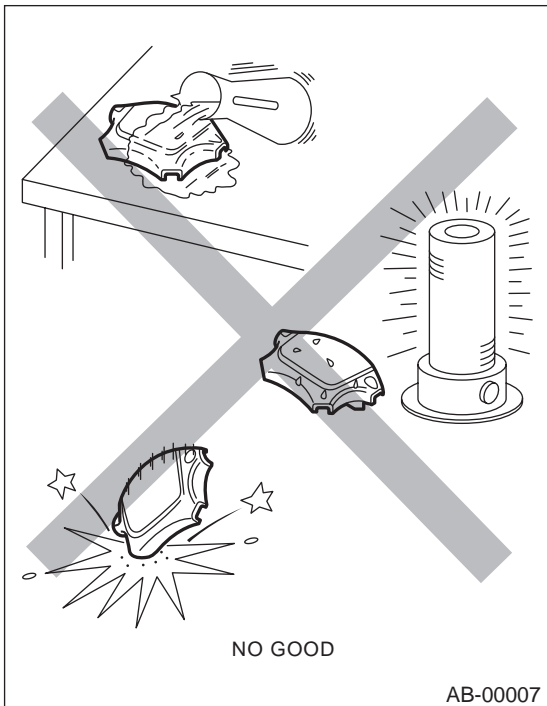

- If any damage, opening, or rust is found on the airbag system wire harness, do not attempt to repair using soldering equipment. Be sure to replace the faulty harness with a new genuine part.

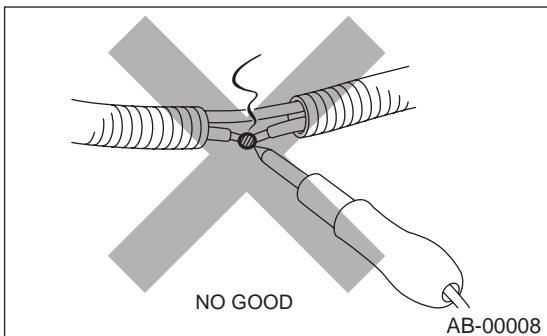

- Install the wire harness securely with the specified clips to avoid interference or tangled up with other parts.

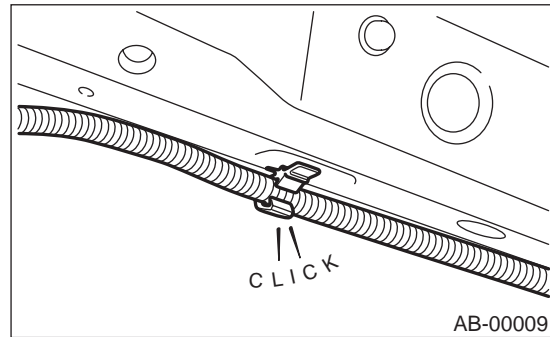

- Do not allow water or oil to come in contact with the connector terminals. Do not touch the connector terminals.

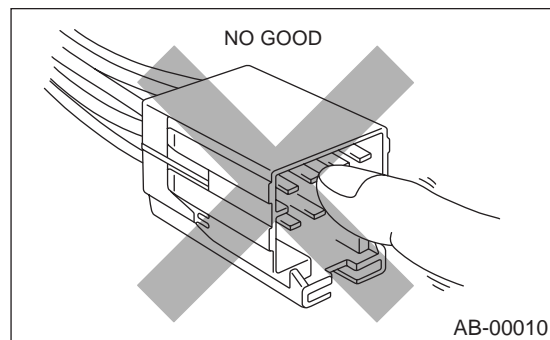

- Either of the airbag parts, or pretensioner must not be disassembled.

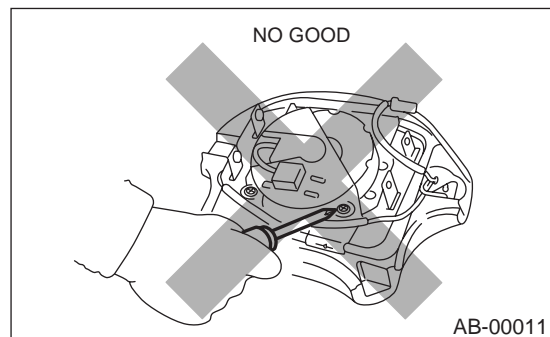

GENERAL DESCRIPTION

AIRBAG SYSTEM

- After removal, keep the airbag module with the pad facing upward on a dry, clean, and flat surface away from heat and light sources, and moisture and dust.

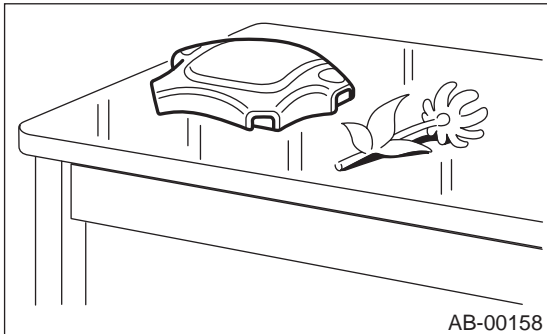

of the welding burner directly to the side airbag sensors and wire harness of the airbag system.

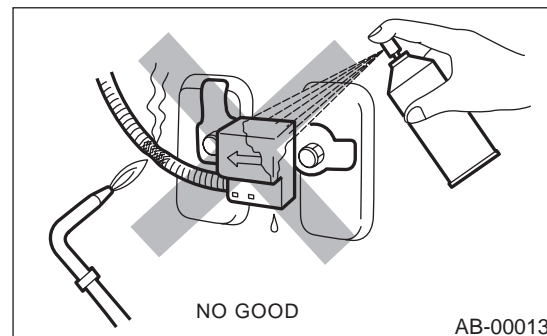

- The removed front seat with the airbag module must be kept at least 200 mm (8 in) away from walls and other objects.

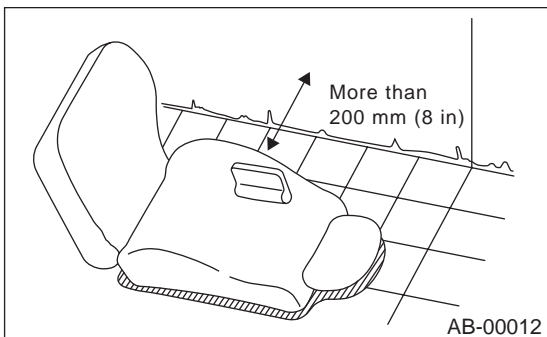

- Do not use the airbag or pretensioner parts from other vehicles. Always replace defective parts with new parts.
- Never re-use a deployed airbag or pretensioner.
- When painting or performing sheet metal work on the front part of the vehicle, including the front wheel apron, front fender, and front side frame, remove parts and take utmost care not to apply paint or the flame of the welding burner directly to the front sub sensors and wire harness of the airbag system.
- When painting or performing sheet metal work on the side of the vehicle, including the side sill, center pillar, and front and rear doors, remove parts and take utmost care not to apply paint or the flame

GENERAL DESCRIPTION

AIRBAG SYSTEM

- When storing a removed airbag module, do not place any objects on it or pile airbag modules on top of each other. If the airbag inflates for some reason when it is placed with its pad side facing downward or under any object, a serious accident may result.

(1)

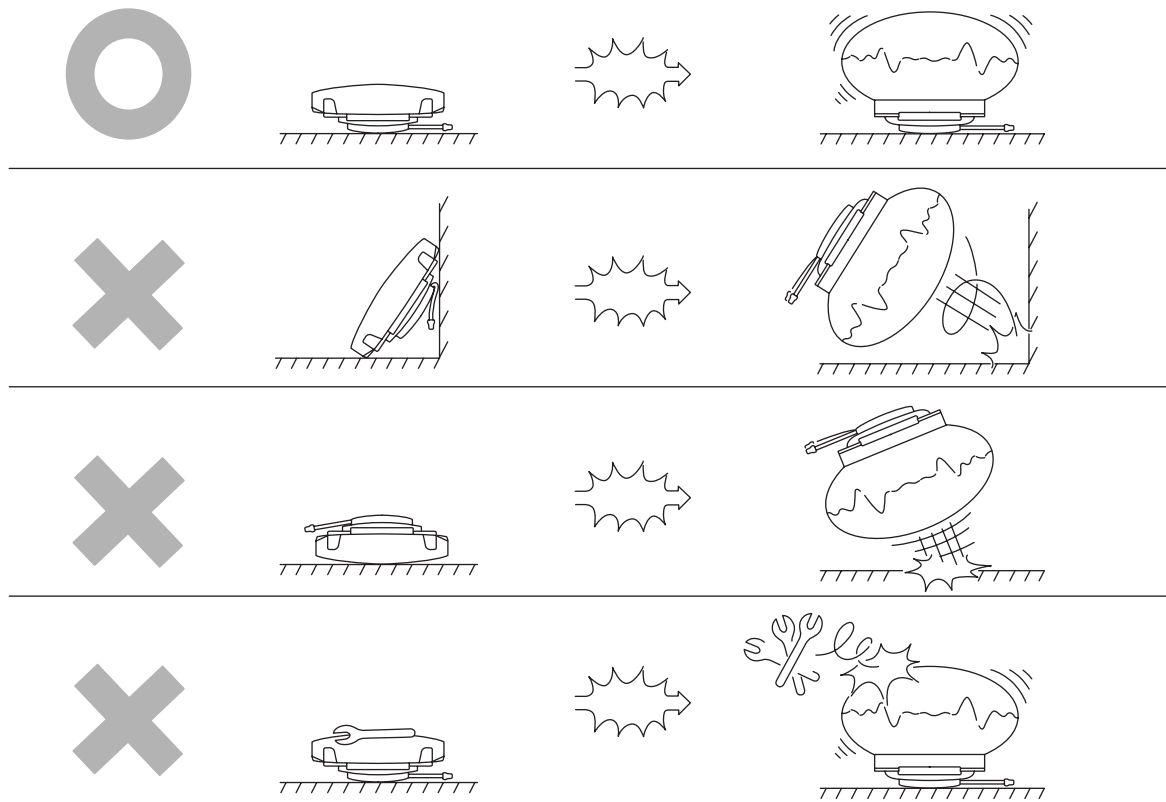

(2)

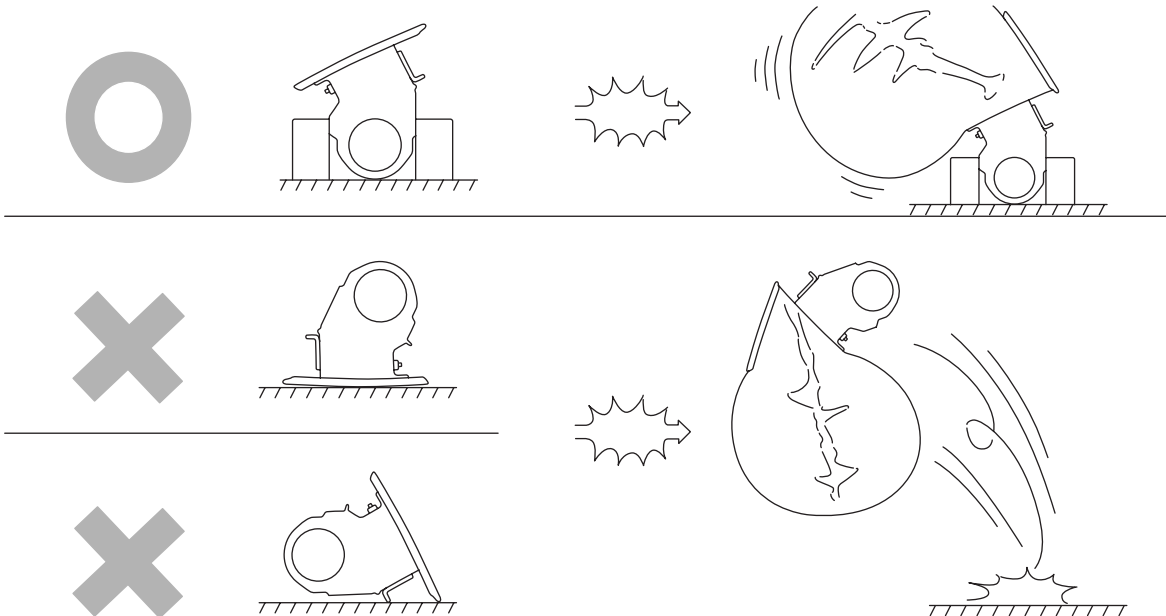

AB-00130

(1) Driver side

(2) Passenger side

GENERAL DESCRIPTION

AIRBAG SYSTEM

C: PREPARATION TOOL

1. GENERAL TOOL

TOOL NAME	REMARKS
TORX® T30	Used for removal/installation of drivers airbag module