

## DATUM POINTS

BODY STRUCTURE

### 2. Datum Points

#### A: LOCATION

##### NOTE:

- Datum points are specified for body repair.
- Guide holes, locators, and indents are provided to facilitate panel replacement and to increase alignment accuracy.
- Both right and left reference points are symmetrical.

#### 1. ROOM SECTION

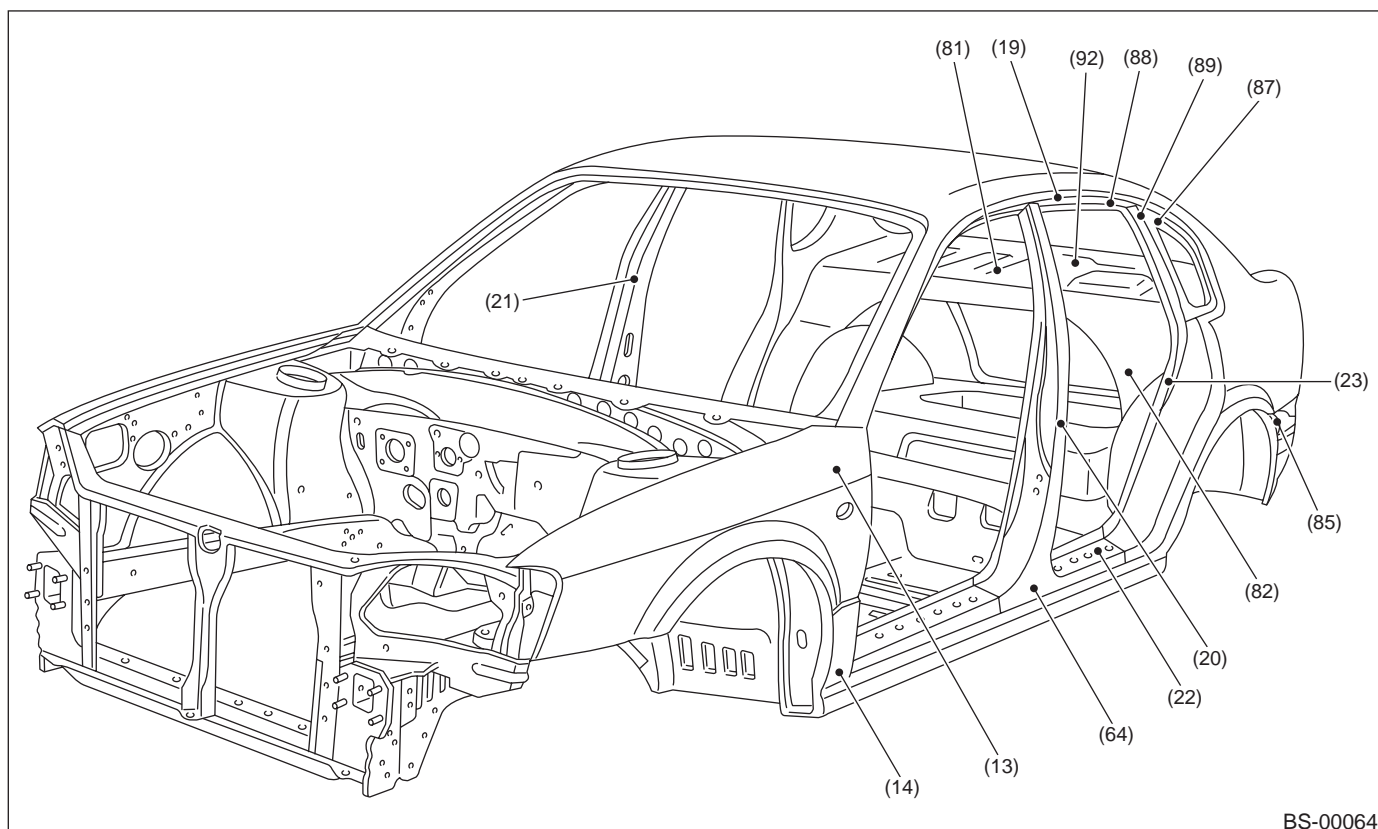

- |  |   |   |
|--|---|---|
| (13) Front fender attaching hole at front pillar center portion M6     | (23) Rear quarter outer door switch attaching hole 20 mm (0.79 in) dia. | (87) Six light glass attaching hole 6.2 mm (0.244 in) dia.                          |
| (14) Front fender attaching hole at front pillar lower portion M6      | (64) Center pillar (LWR) gauge hole 16 mm (0.63 in) dia.                | (88) Retainer attaching square hole at side rail outer 8 × 8 mm (0.31 × 0.31 in)    |
| (19) Retainer attaching hole at side rail outer 3.2 mm (0.126 in) dia. | (81) Panel rear center (UPR) gauge hole 8 mm (0.31 in) dia.             | (89) Retainer attaching square hole at rear quarter outer 8 × 8 mm (0.31 × 0.31 in) |
| (20) Center pillar outer hole 14 mm (0.55 in) dia.                     | (82) Bulk head rear trim clip hole 7 mm (0.28 in) dia.                  | (92) Rear panel center hole (UPR) 6 mm (0.24 in) dia.                               |
| (21) Front seat belt adjust plate attaching hole M10                   | (85) Rear quarter outer gauge hole 20 mm (0.79 in) dia.                 |   |
| (22) Side sill outer hole 20 mm (0.79 in) dia.                         |   |   |

## DATUM POINTS

### BODY STRUCTURE

#### 2. REAR SECTION

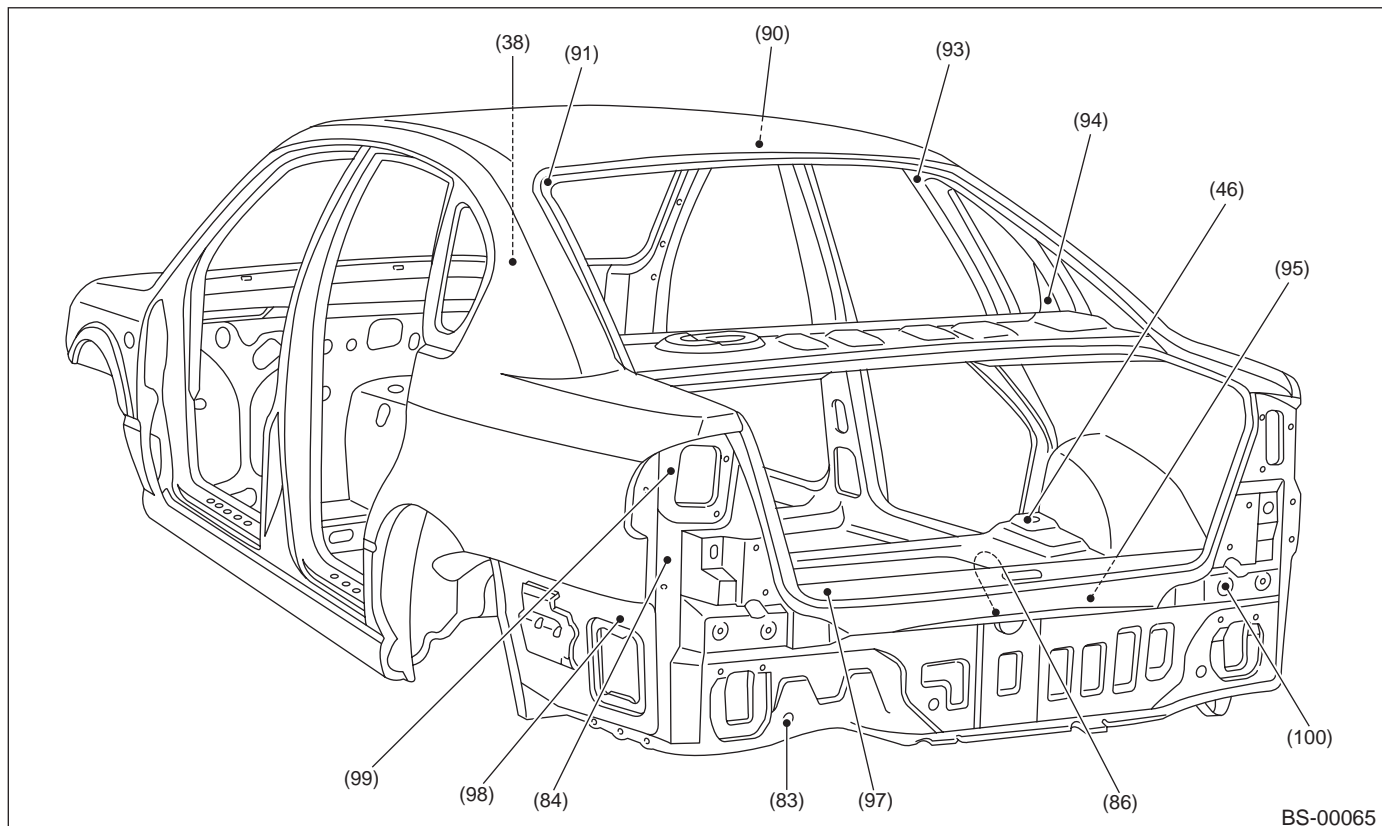

BS-00065

- |   |  |  |
|---|--|--|
| (38) Front panel instrument panel attaching hole 18 × 36 mm (0.71 × 1.42 in) dia. oblong hole | (90) Rear rear roof trim attaching hole 8 mm (0.31 in) dia.  | (97) Trunk trim attaching hole at rear skirt 7 mm (0.28 in) dia.   |
| (46) Rear/front shock absorber floor side attaching hole 13 mm (0.51 in) dia.                 | (91) Rear glass attaching hole<br>RH: 6.5 mm (0.256 in) dia.<br>LH: (6.5 × 10 mm (0.256 × 0.394 in) oval | (98) Rear bumper slider attaching hole 6.2 mm (0.244 in) dia.  |
| (83) Rear skirt outer burring hole 20 mm (0.79 in) dia.                                       | (93) Rear panel inner trim attaching hole (UPR) 8 mm (0.31 in) dia.                                      | (99) Rear combination light mounting hole 8 mm (0.31 in) dia.  |
| (84) Rear extension attaching hole 6.2 mm (0.244 in) dia.                                     | (94) Rear panel inner trim attaching hole (LWR) 8 mm (0.31 in) dia.                                      | (100) Rear bumper beam attaching hole 8.2 mm (0.323 in) dia.<br>RH: 8.2 mm (0.323 in)<br>LH: 8.2 × 12 mm (0.323 × 0.472 in) oval |
| (86) Reinforce striker trim attaching hole 7 mm (0.28 in) dia.                                | (95) Rear bumper attaching hole 12.5 × 17 mm (0.492 × 0.669 in) dia. oblong hole                         |  |

## DATUM POINTS

BODY STRUCTURE

### 3. UNDERBODY SECTION

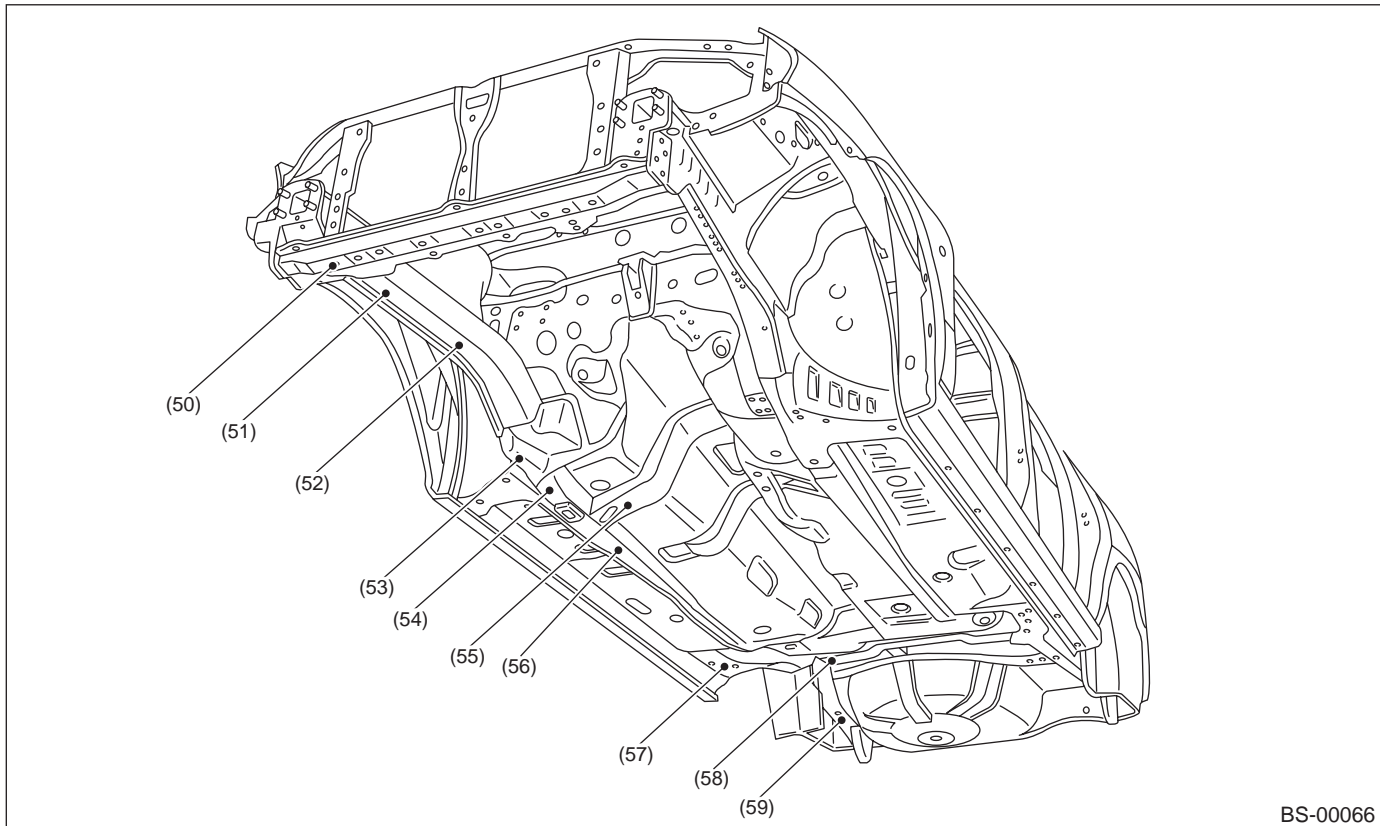

BS-00066

- |   |  |  |
|---|--|--|
| (50) Radiator panel (LWR) frame gauge hole 15 mm (0.59 in) dia. | (54) Front side frame (Rr) gauge hole 20 mm (0.79 in) dia. | (58) Reinforcement crossmember B hole RH: 15 mm (0.59 in) dia., LH: 12 mm (0.47 in) dia. |
| (51) Front side frame (Ft) gauge hole 20 mm (0.79 in) dia.      | (55) Crossmember front floor gauge hole M10                | (59) Frame rear floor side gauge hole 30 mm (1.18 in) dia.                               |
| (52) Front side frame (Ft) gauge hole 20 mm (0.79 in) dia.      | (56) Front side frame (Rr) gauge hole 18 mm (0.71 in) dia. |  |
| (53) Front suspension bracket COMPL securing nut (M14)          | (57) Frame rear floor side gauge hole 25 mm (0.98 in) dia. |  |

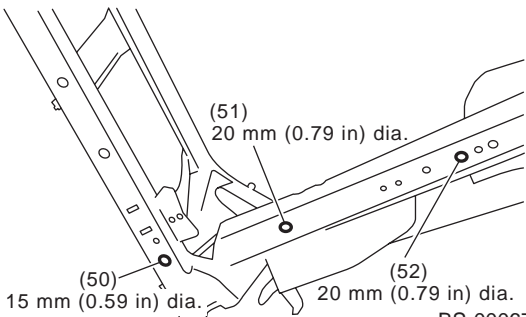
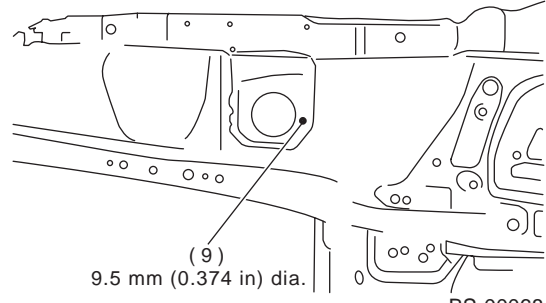
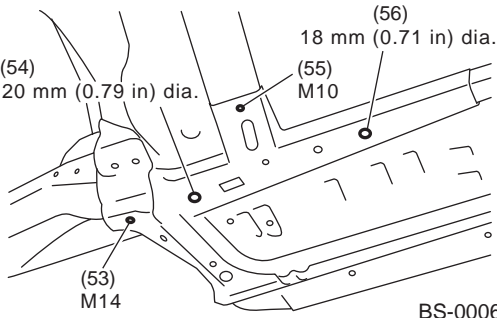
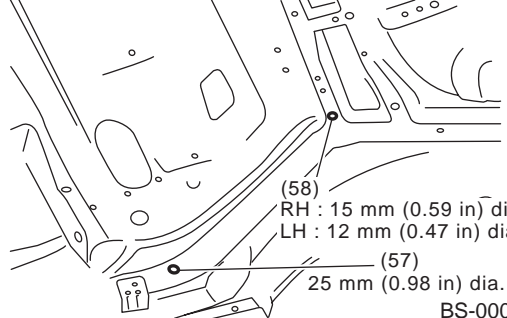
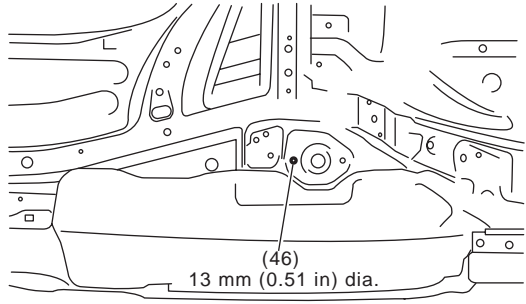
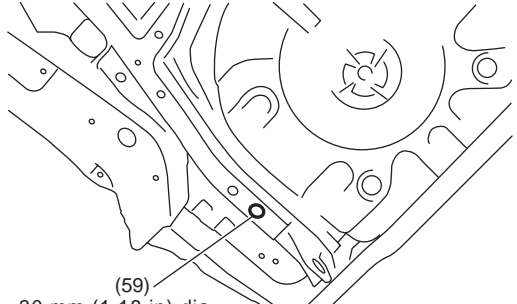
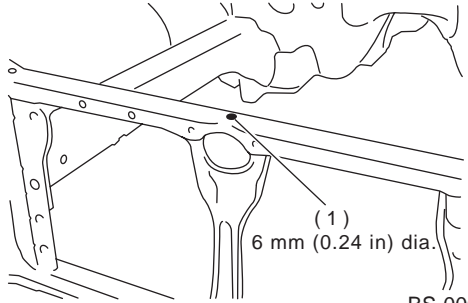
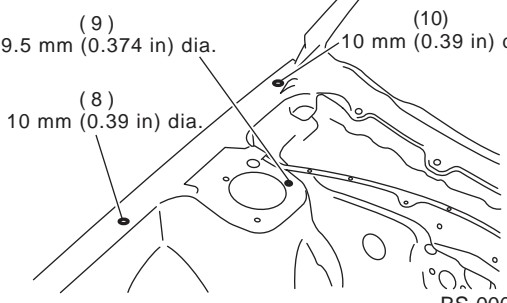

## DATUM POINTS

### BODY STRUCTURE

 <p>(51) 20 mm (0.79 in) dia.</p> <p>(50) 15 mm (0.59 in) dia.</p> <p>(52) 20 mm (0.79 in) dia.</p> <p style="text-align: right;">BS-00067</p>	 <p>(9) 9.5 mm (0.374 in) dia.</p> <p style="text-align: right;">BS-00068</p>
 <p>(54) 20 mm (0.79 in) dia.</p> <p>(53) M14</p> <p>(55) M10</p> <p>(56) 18 mm (0.71 in) dia.</p> <p style="text-align: right;">BS-00069</p>	 <p>(58) RH : 15 mm (0.59 in) dia. LH : 12 mm (0.47 in) dia.</p> <p>(57) 25 mm (0.98 in) dia.</p> <p style="text-align: right;">BS-00070</p>
 <p>(46) 13 mm (0.51 in) dia.</p> <p style="text-align: right;">BS-00071</p>	 <p>(59) 30 mm (1.18 in) dia.</p> <p style="text-align: right;">BS-00072</p>
 <p>(1) 6 mm (0.24 in) dia.</p> <p style="text-align: right;">BS-00073</p>	 <p>(9) 9.5 mm (0.374 in) dia.</p> <p>(10) 10 mm (0.39 in) dia.</p> <p>(8) 10 mm (0.39 in) dia.</p> <p style="text-align: right;">BS-00074</p>

# DATUM POINTS

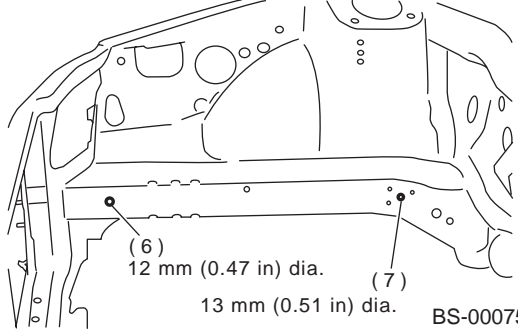
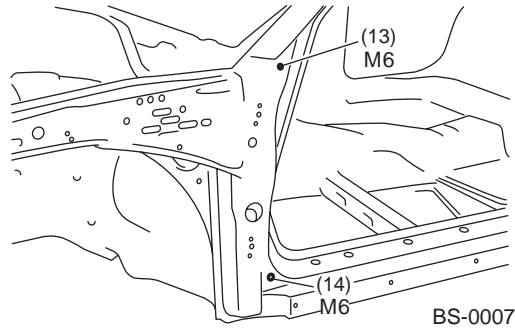
## BODY STRUCTURE

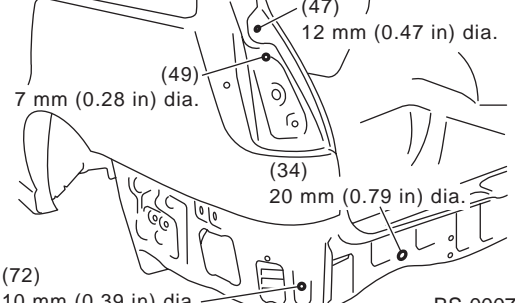
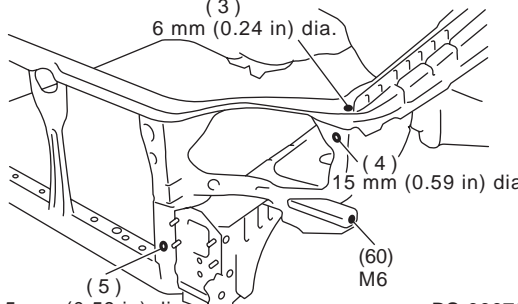
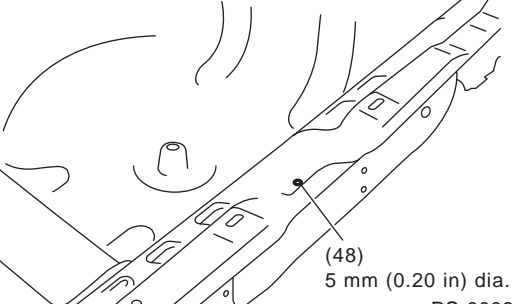
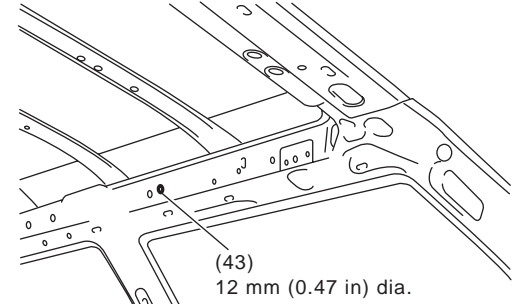
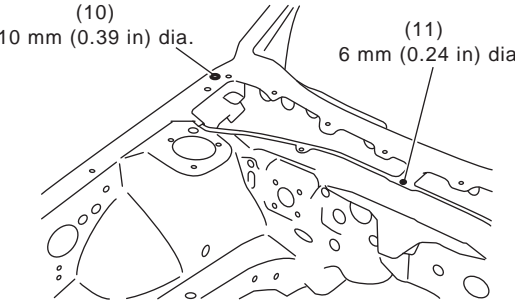
 <p>(6) 12 mm (0.47 in) dia.</p> <p>(7) 13 mm (0.51 in) dia.</p> <p>BS-00075</p>	 <p>(13) M6</p> <p>(14) M6</p> <p>BS-00076</p>
 <p>(11) 6 mm (0.24 in) dia.</p> <p>BS-00077</p>	 <p>(47) 12 mm (0.47 in) dia.</p> <p>(49) 7 mm (0.28 in) dia.</p> <p>(34) 20 mm (0.79 in) dia.</p> <p>(72) 10 mm (0.39 in) dia.</p> <p>BS-00078</p>
 <p>(3) 6 mm (0.24 in) dia.</p> <p>(4) 15 mm (0.59 in) dia.</p> <p>(5) 15 mm (0.59 in) dia.</p> <p>(60) M6</p> <p>BS-00079</p>	 <p>(48) 5 mm (0.20 in) dia.</p> <p>BS-00080</p>
 <p>(43) 12 mm (0.47 in) dia.</p> <p>BS-00081</p>	 <p>(10) 10 mm (0.39 in) dia.</p> <p>(11) 6 mm (0.24 in) dia.</p> <p>BS-00082</p>

## DATUM POINTS

### BODY STRUCTURE

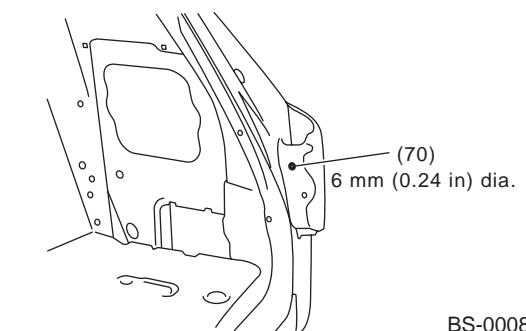
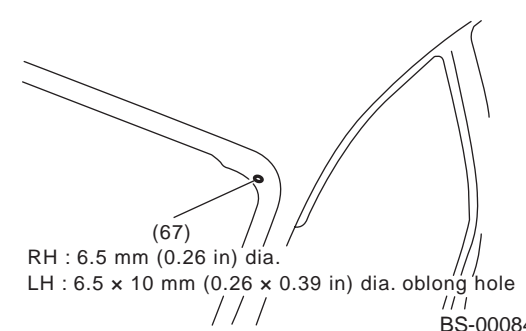
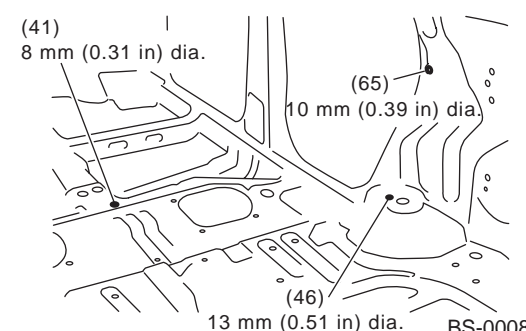
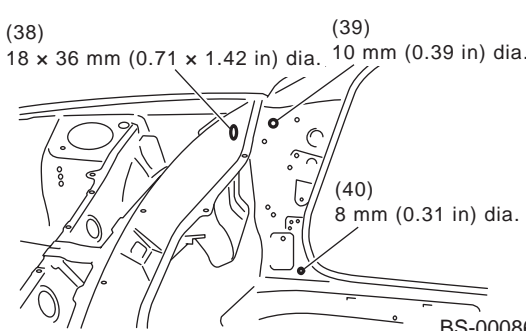
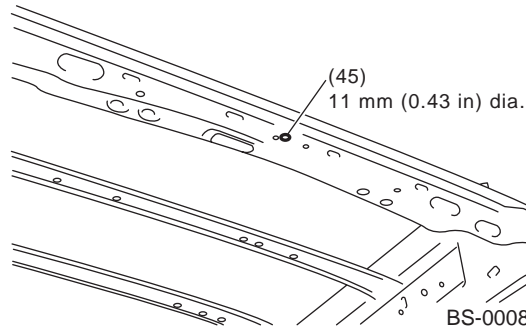
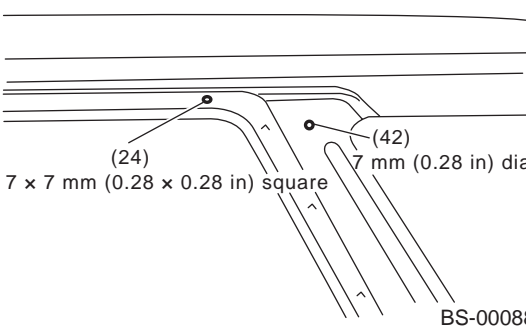
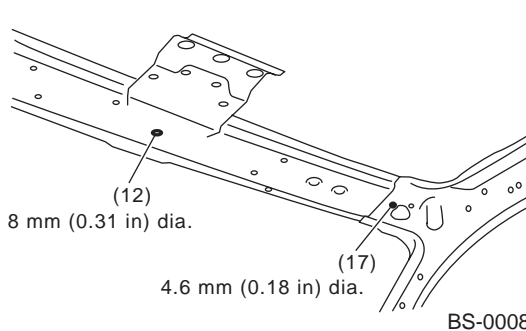
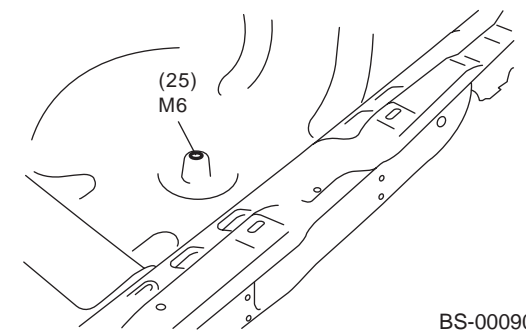
 <p>(70) 6 mm (0.24 in) dia.</p> <p style="text-align: right;">BS-00083</p>	 <p>(67) RH : 6.5 mm (0.26 in) dia. LH : 6.5 x 10 mm (0.26 x 0.39 in) dia. oblong hole</p> <p style="text-align: right;">BS-00084</p>
 <p>(41) 8 mm (0.31 in) dia.</p> <p>(65) 10 mm (0.39 in) dia.</p> <p>(46) 13 mm (0.51 in) dia.</p> <p style="text-align: right;">BS-00085</p>	 <p>(38) 18 x 36 mm (0.71 x 1.42 in) dia.</p> <p>(39) 10 mm (0.39 in) dia.</p> <p>(40) 8 mm (0.31 in) dia.</p> <p style="text-align: right;">BS-00086</p>
 <p>(45) 11 mm (0.43 in) dia.</p> <p style="text-align: right;">BS-00087</p>	 <p>(24) 7 x 7 mm (0.28 x 0.28 in) square</p> <p>(42) 7 mm (0.28 in) dia.</p> <p style="text-align: right;">BS-00088</p>
 <p>(12) 8 mm (0.31 in) dia.</p> <p>(17) 4.6 mm (0.18 in) dia.</p> <p style="text-align: right;">BS-00089</p>	 <p>(25) M6</p> <p style="text-align: right;">BS-00090</p>

# DATUM POINTS

## BODY STRUCTURE

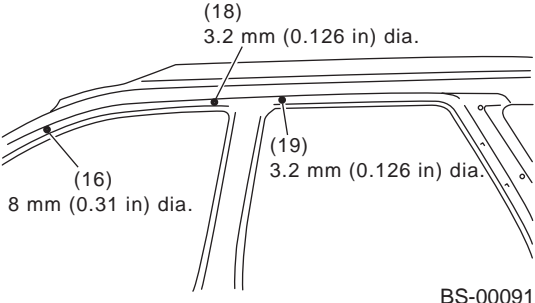
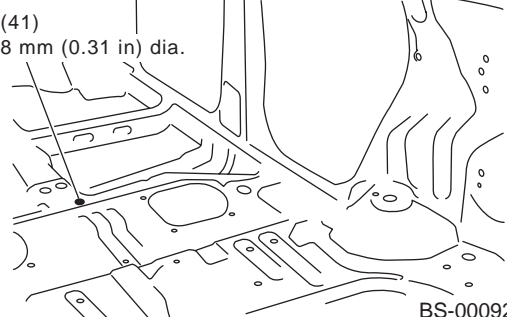
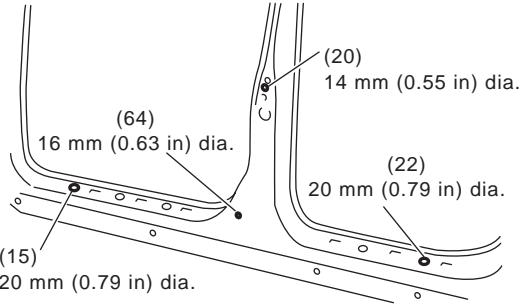
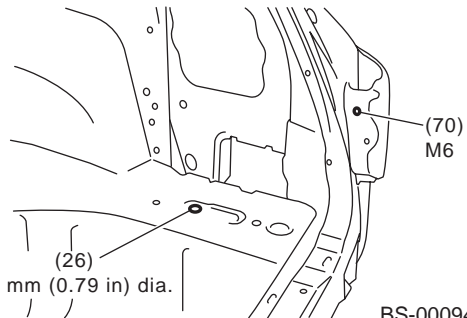
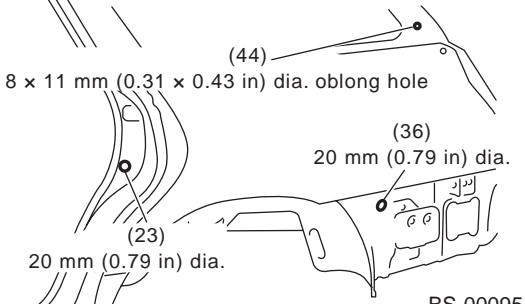
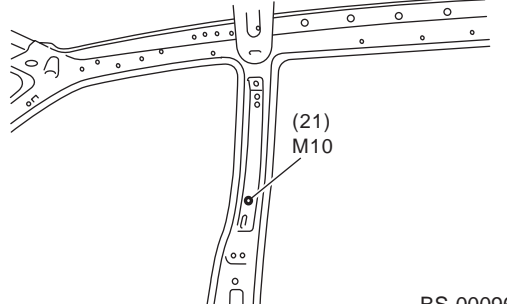
 <p>(18) 3.2 mm (0.126 in) dia.</p> <p>(16) 8 mm (0.31 in) dia.</p> <p>(19) 3.2 mm (0.126 in) dia.</p> <p>BS-00091</p>	 <p>(41) 8 mm (0.31 in) dia.</p> <p>BS-00092</p>
 <p>(20) 14 mm (0.55 in) dia.</p> <p>(64) 16 mm (0.63 in) dia.</p> <p>(22) 20 mm (0.79 in) dia.</p> <p>(15) 20 mm (0.79 in) dia.</p> <p>BS-00093</p>	 <p>(70) M6</p> <p>(26) 20 mm (0.79 in) dia.</p> <p>BS-00094</p>
 <p>(44) 8 x 11 mm (0.31 x 0.43 in) dia. oblong hole</p> <p>(36) 20 mm (0.79 in) dia.</p> <p>(23) 20 mm (0.79 in) dia.</p> <p>BS-00095</p>	 <p>(21) M10</p> <p>BS-00096</p>