

CRUISE CONTROL COMMAND SWITCH

CRUISE CONTROL SYSTEM

5. Cruise Control Command Switch

A: REMOVAL

WARNING:

Before servicing, be sure to read the notes in the AB section for proper handling of the driver's airbag module. <Ref. to AB-3, CAUTION, GENERAL DESCRIPTION.>

- 1) Set front wheels in straight ahead position.
- 2) Turn ignition switch OFF.
- 3) Disconnect ground cable from battery and wait for at least 20 seconds before starting work.
- 4) Using TORX® BIT T30 (Tamper resistant type), loosen two TORX® bolts which secure driver's airbag module.

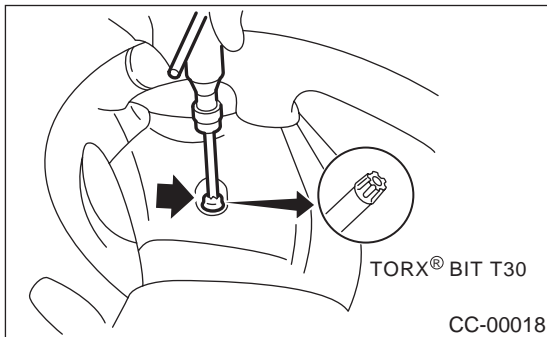

- 5) Disconnect airbag module connector on back of airbag module.
- 6) Remove horn switch from steering wheel as shown.

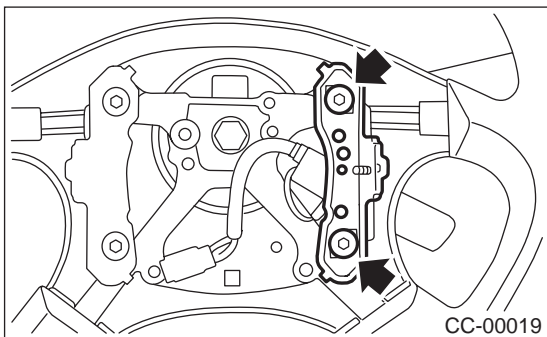

- 7) Disconnect horn and cruise control command switch connector, then remove cruise control command switch.

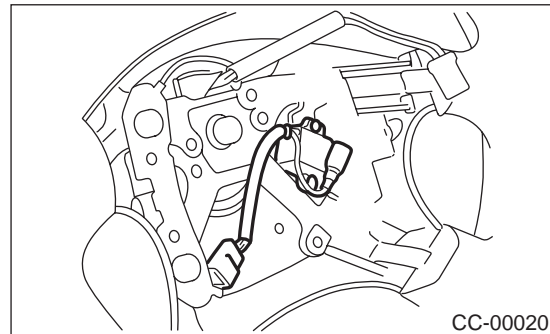

B: INSTALLATION

Install is in the reverse order of removal.

C: INSPECTION

Measure cruise control command switch resistance.

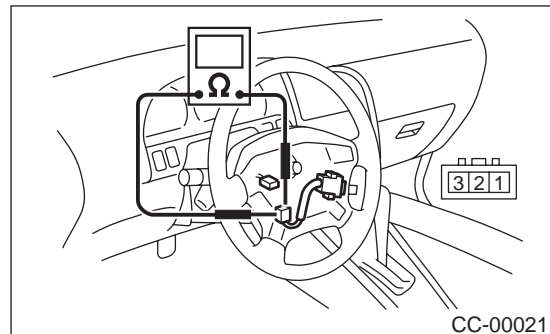

Check continuity between cruise control command switch terminals.

Switch	Position	Terminal No.	Standard
CANCEL	ON	1 (+) and 2 (-)	Less than 1 Ω
	ON	1 (+) and 3 (-)	Less than 1 Ω
SET/ COAST	OFF	1 and 2	More than 1 MΩ
	ON	1 and 2	Less than 1 Ω
RESUME/ ACCEL	OFF	1 and 3	More than 1 MΩ
	ON	1 and 3	Less than 1 Ω

If NG, replace cruise control command switch.