

REAR REGULATOR AND MOTOR ASSEMBLY

GLASS/WINDOWS/MIRRORS

9. Rear Regulator and Motor Assembly

A: REMOVAL

- 1) Remove door trim. <Ref. to EI-33, REMOVAL, Rear Door Trim.>
- 2) Remove sealing cover. <Ref. to EB-16, REMOVAL, Rear Sealing Cover.>
- 3) Remove door glass. <Ref. to GW-17, REMOVAL, Rear Door Glass.>
- 4) Secure bolts using screwdriver to remove front sash adjusting nut.

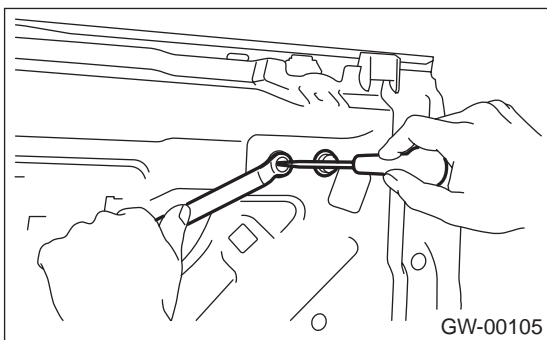

- 5) Remove front sash.
- 6) Disconnect electrical connector.
- 7) Loosen four bolts and two nuts to remove regulator assembly.

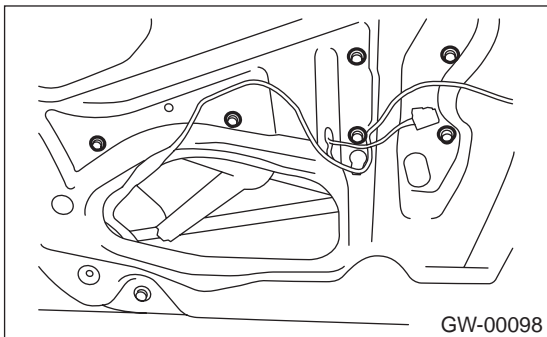

- 8) Loosen screws to remove motor assembly.

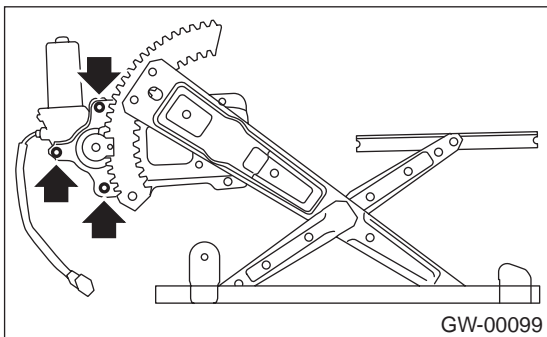

B: INSTALLATION

- 1) Install in the reverse order of removal.
- 2) Adjust rear door glass. <Ref. to GW-17, ADJUSTMENT, Rear Door Glass.>

Tightening torque:

Refer to **COMPONENT** in *General Description*. <Ref. to **EB-5, REAR DOOR PANEL, COMPONENT, General Description.**> and <Ref. to **GW-5, REAR DOOR GLASS, COMPONENT, General Description.**>

C: INSPECTION

- 1) Make sure that power window motor rotates properly when battery voltage is applied to terminals of motor connector.
- 2) Change polarity of battery connections to terminals to ensure that motor rotates in reverse direction.