

WINDSHIELD GLASS

GLASS/WINDOWS/MIRRORS

10. Windshield Glass

A: REMOVAL

1. USING WINDSHIELD KNIFE

- 1) Remove cowl panel. <Ref. to EI-27, REMOVAL, Cowl Panel.>
- 2) Remove front side molding and upper front molding.
- 3) Tape body side of the circumference of windshield glass for protection.
- 4) Apply sufficient amount of soapy water to adhesive layer.
- 5) Insert windshield knife into the adhesive layer.
- 6) While holding the knife edge and windshield glass edge at a right angle, move windshield knife in parallel to windshield glass edge along face and edge of windshield glass to cut the adhesive layer.

CAUTION:

- Do not twist windshield knife.
- Cutting of adhesive layer shall be started with wider gap between windshield glass and body.

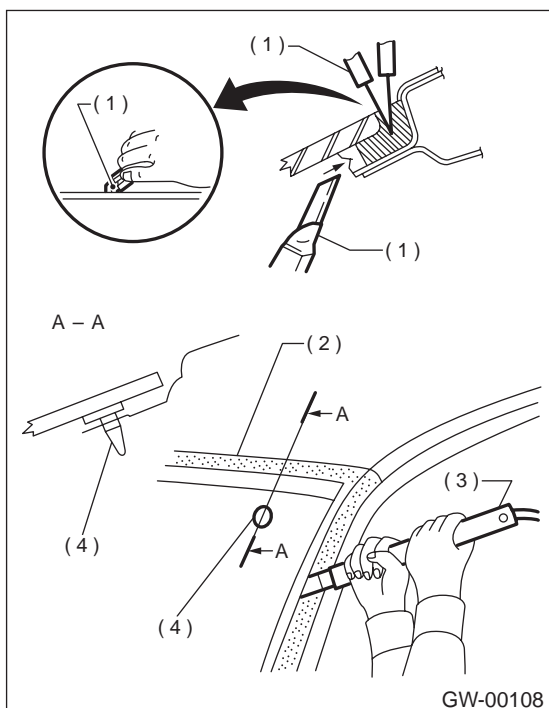

- (1) Putty knife
- (2) Protective tape
- (3) Windshield knife
- (4) Matching pin

NOTE:

Because matching pins are bonded to the corners of glass, use piano wire to cut the pin.

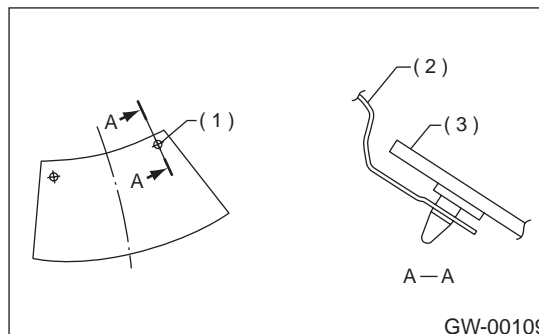

- (1) Matching pin
- (2) Body panel
- (3) Glass

2. USING PIANO WIRE

- 1) Remove cowl panel. <Ref. to EI-27, REMOVAL, Cowl Panel.>
- 2) Remove roof molding and upper front molding.
- 3) Tape the body side of the circumference of windshield glass for protection.
- 4) Make a hole in adhesive layer using drill or knife.
- 5) Pass piano wire through the hole, and attach securely both the wire ends to pieces of wood.

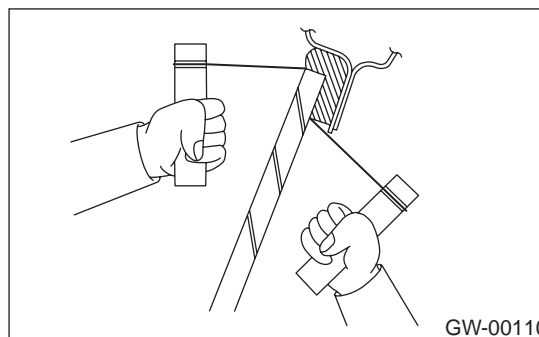

- 6) Pull the wire ends alternately to cut off the adhesive layer.

CAUTION:

- Do not tightly pull the piano wire against the windshield glass edge.
- Be careful not to damage interior and exterior parts.
- When removal is made with area close to instrument panel, place a protection plate over it. Pay particular attention to the removal.
- Do not cross piano wires. Otherwise they may be cut.

WINDSHIELD GLASS

GLASS/WINDOWS/MIRRORS

B: INSTALLATION

- 1) Clean external circumference of windshield glass with alcohol or white gasoline.
- 2) Remove adhesive layer on the body using cutter knife to obtain smooth face 2 mm (0.08 in) thick.

CAUTION:

Be careful not to damage the body and paint surface.

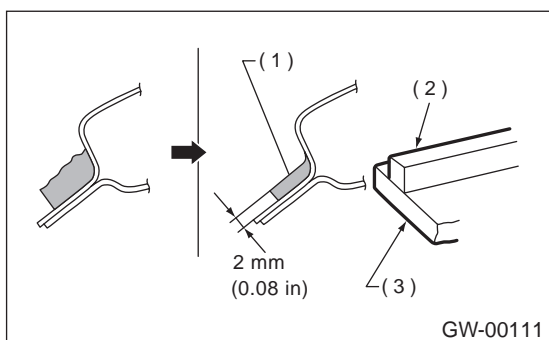

- (1) Adhesive
- (2) Dam rubber
- (3) Glass

- 3) Clean body with alcohol or white gasoline to remove thoroughly chips, dusts, and dirt from body face.
- 4) Place glass on body.
- 5) Adjust glass position to make uniform clearance between body and glass in four corners.
- 6) Place matching pins (A) and body on glass.

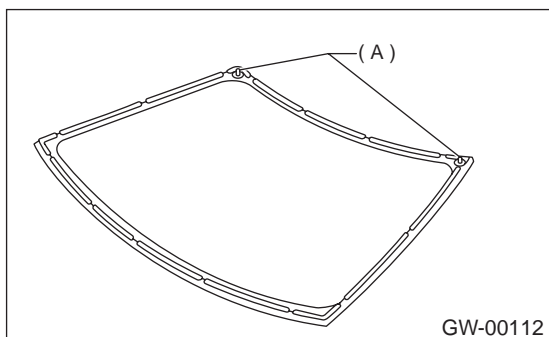

- 7) Remove glass from body.

- 8) Fit molding mark (B) to notch (A) of ceramic print.

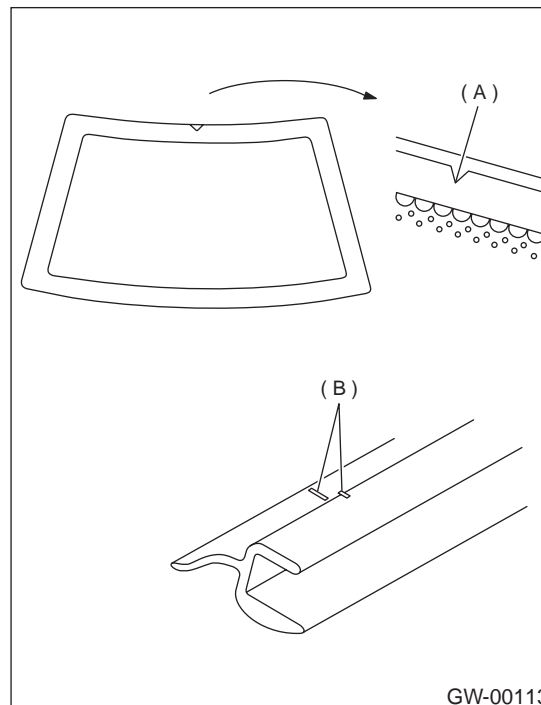

- 9) Apply primer to adhesive layer (A) of glass (B) using sponge.
- 10) Apply primer to adhesive layer (A) of body (C).

CAUTION:

- Primer once attached to the painted surface of the body and internal trim is hard to wipe off. Mask the circumference of such areas.
- Let primer dry for about ten minutes before installing the glass.
- Do not touch surface coated with primer.

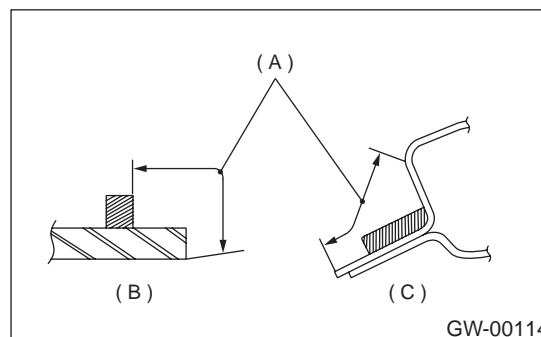

WINDSHIELD GLASS

GLASS/WINDOWS/MIRRORS

11) Cut off cartridge nozzle tip and set it in sealant gun as shown.

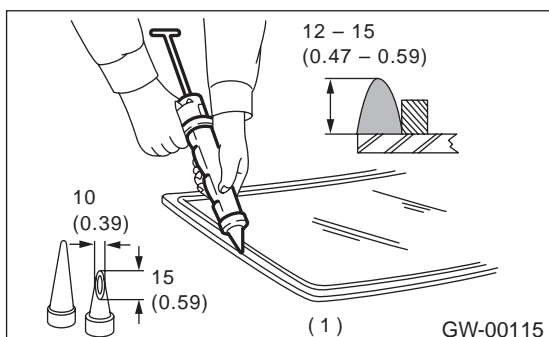

12) Apply adhesive to glass end surface as shown.

13) Fit matching pins using suction rubber cup to install windshield glass.

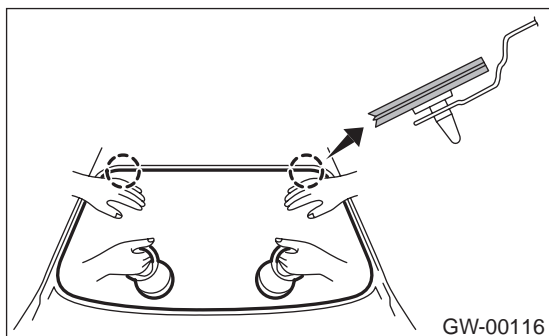

14) Lightly press windshield glass for tight fit.

15) Make adhesive surface flush using spatula.

CAUTION:

- When door is opened/closed after glass is bonded, always lower door glass and then open/close it carefully.
- Move vehicle slowly.

16) After completion of all work, allow vehicle to stand for about 24 hours.

NOTE:

For minimum drying time and time the vehicle must be left standing before driving after bonding, follow instructions or instruction manual from the adhesive manufacturer.

17) After curing of adhesive, pour water on external surface of vehicle to check that there are no water leaks.

CAUTION:

When a vehicle is returned to the user, tell him or her that the vehicle should not be subjected to heavy impact for at least three days.

18) Install cowl panel. <Ref. to EI-27, INSTALLATION, Cowl Panel.>