

REAR QUARTER GLASS

GLASS/WINDOWS/MIRRORS

12.Rear Quarter Glass

A: REMOVAL

1. SEDAN

Remove glass in the same procedure as for windshield glass. <Ref. to GW-20, REMOVAL, Windshield Glass.>

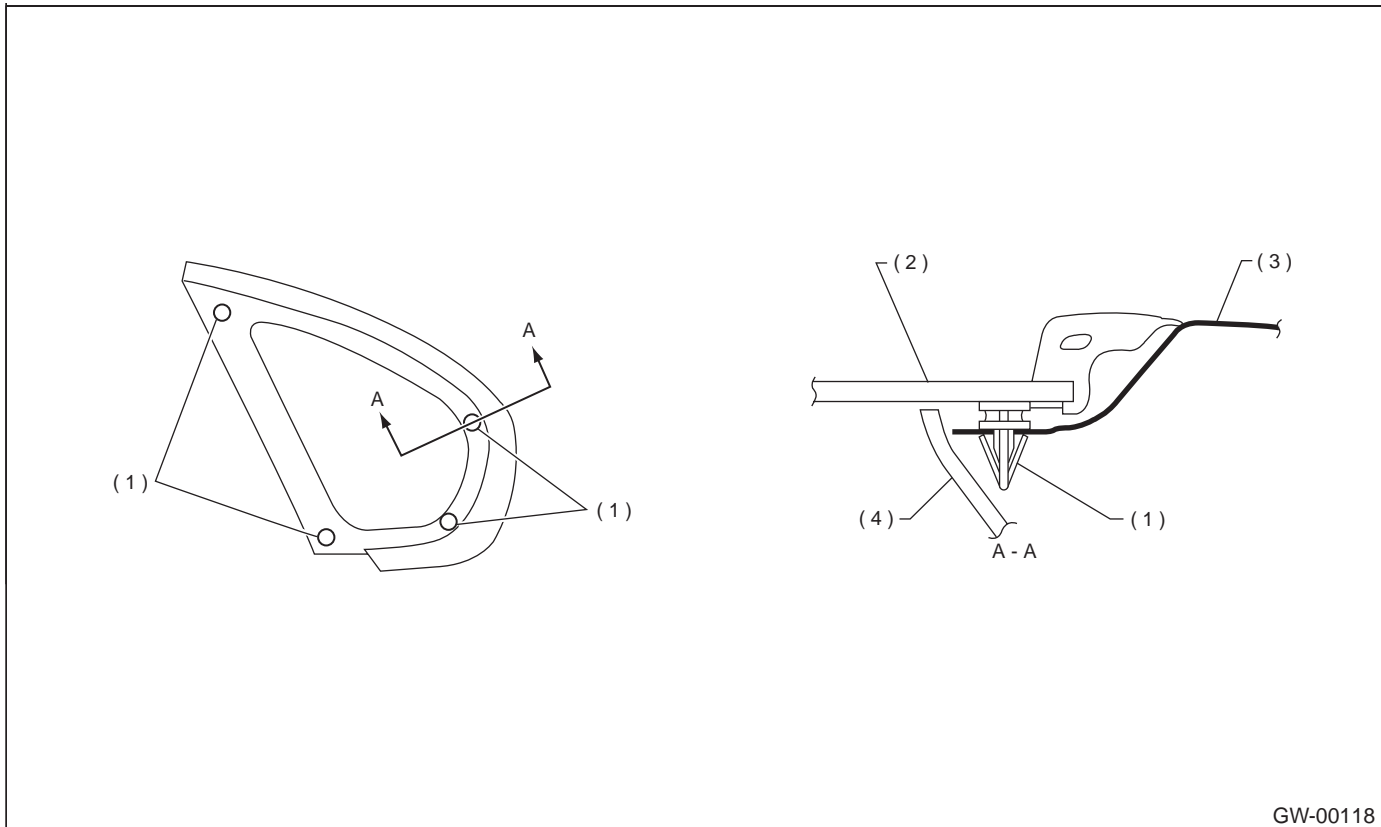

GW-00118

- (1) Matching pin
- (2) Rear quarter glass

- (3) Body panel
- (4) Trim panel

REAR QUARTER GLASS

GLASS/WINDOWS/MIRRORS

2. WAGON

Remove glass in the same procedure as for windshield glass. <Ref. to GW-20, REMOVAL, Windshield Glass.>

B: INSTALLATION

1) Cut off nozzle tip as shown in the figure.

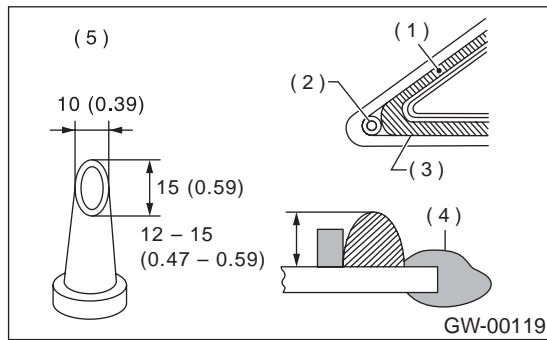

- (1) Dam rubber
- (2) Matching pin
- (3) Adhesive
- (4) Molding
- (5) Unit: mm (in)

2) Install glass in the same procedure as for windshield glass. <Ref. to GW-21, INSTALLATION, Windshield Glass.>

CAUTION:

- When door is opened/closed after glass is bonded, always lower door glass and then open/close it carefully.
- Move vehicle slowly.

3) After completion of all work, allow vehicle to stand for about 24 hours.

NOTE:

For minimum drying time and time the vehicle must be left standing before driving after bonding, follow instructions or instruction manual from the adhesive manufacturer.

4) After curing of adhesive, pour water on external surface of vehicle to check that there are no water leaks.

CAUTION:

When a vehicle is returned to the user, tell him or her that the vehicle should not be subjected to heavy impact for at least three days.