

## FLEXIBLE HOSE

HVAC SYSTEM (HEATER, VENTILATOR AND A/C)

### 16.Flexible Hose

#### A: REMOVAL

##### CAUTION:

- When disconnecting/connecting hoses, do not apply excessive force them. Confirm that no torsion and excessive tension exist after installing.
- Seal the disconnected hose with a plug or vinyl tape to prevent contamination from entering.

- 1) Disconnect ground cable from battery.
- 2) Using refrigerant recovery system, discharge refrigerant. <Ref. to AC-18, OPERATION, Refrigerant Recovery Procedure.>
- 3) Remove duct (A).

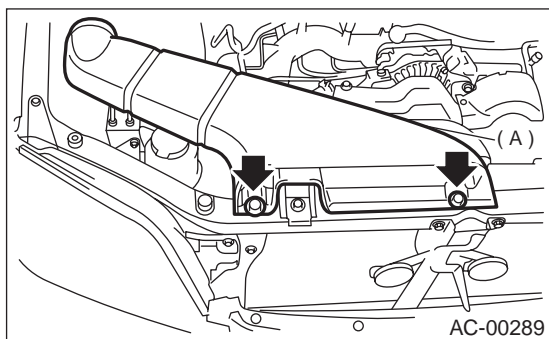

- 4) Remove hose attaching bolts (C).
- 5) Disconnect hose from evaporator unit.
- 6) Disconnect hose from compressor.
- 7) Remove low-pressure hose (A) from the vehicle.
- 8) Remove hose attaching bolts (D).
- 9) Disconnect hose from compressor.
- 10) Disconnect hose from condenser.

- 11) Disconnect high-pressure hose (B) from the vehicle.

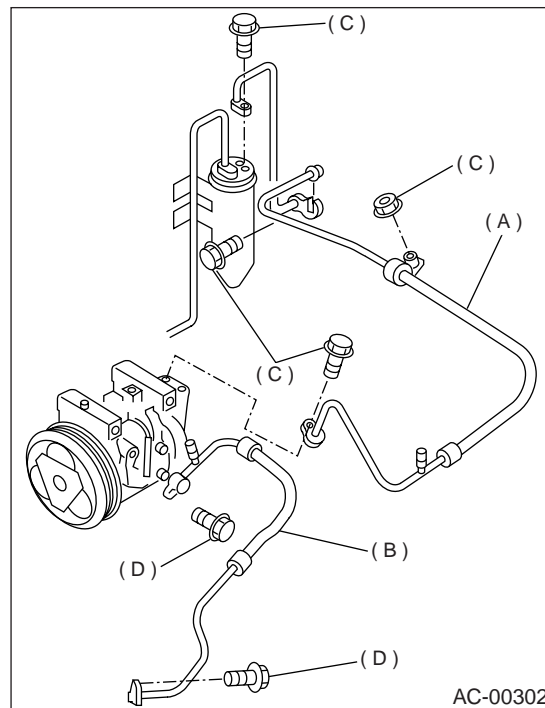

#### B: INSTALLATION

##### CAUTION:

When disconnecting/connecting hoses, do not apply an excessive force them. Confirm that no torsion and excessive tension exist after installing. Seal the disconnected hose with a plug or vinyl tape to prevent contamination from entering.

- 1) Install in the reverse order of removal.
- 2) Charge refrigerant. <Ref. to AC-19, OPERATION, Refrigerant Charging Procedure.>

##### Tightening torque:

Refer to **COMPONENT** of *General Description*

<Ref. to AC-9, AIR CONDITIONING UNIT, COMPONENT, General Description.>

#### C: INSPECTION

##### NOTE:

If cracking, damage, or swelling is found on a hose, replace it with a new one.