

9. Headlight Assembly

A: REMOVAL

- 1) Disconnect ground cable from battery.
- 2) Remove duct (A) (when right side headlight is removed).

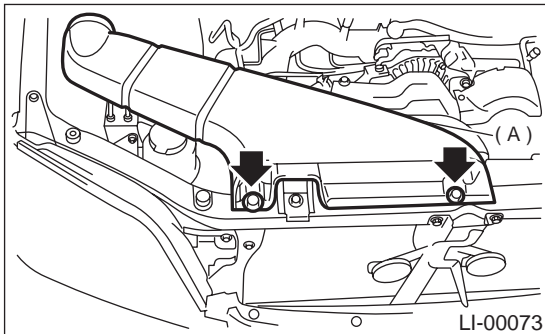

- 3) Disconnect headlight bulb connector.
Single-bulb type

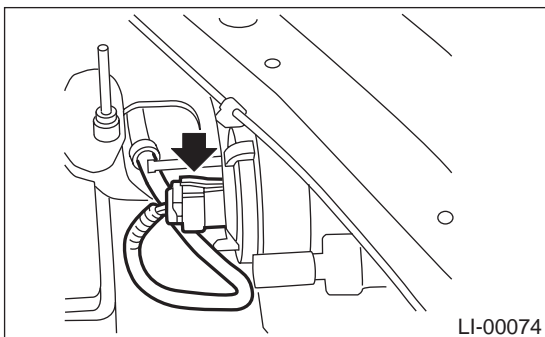

Dual-bulb type

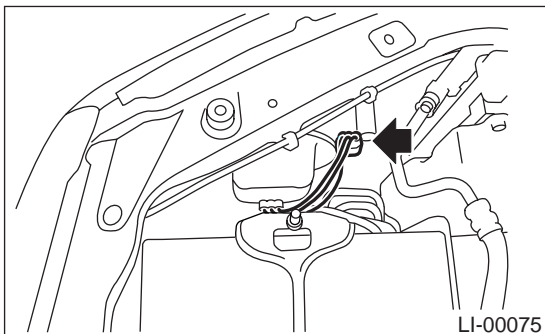

- 4) Remove three bolts and disconnect connectors, and then detach headlight assembly.

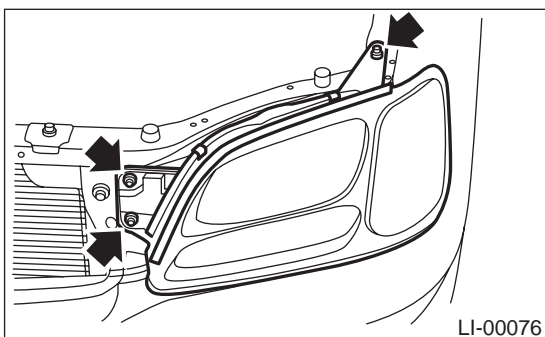

B: INSTALLATION

Install in the reverse order of removal.

C: ADJUSTMENT

1. HEADLIGHT AIMING

NOTE:

As this headlight is the "VISUAL AIMING TYPE", it is possible to adjust aiming only in the vertical direction. It cannot be adjusted in the horizontal direction.

CAUTION:

Turn off the light before adjusting headlight aiming. If the light is necessary to check aiming, do not turn on for more than two minutes.

NOTE:

Before checking the headlight aiming, be sure of the following:

- The area around the headlight has not sustained any accident, damage or other type of deformation.
- Vehicle is parked on level ground.
- The inflation pressure of tires is correct.
- Vehicle's gas tank is fully charged.
- Bounce the vehicle several times to normalize the suspension.
- Make certain that someone is seated in the driver's seat.

Turn the headlights on and then adjust the low beam pattern to the following positions on the screen.

NOTE:

Adjust the headlight aiming by turning the adjusting screw (A).

Single-bulb type

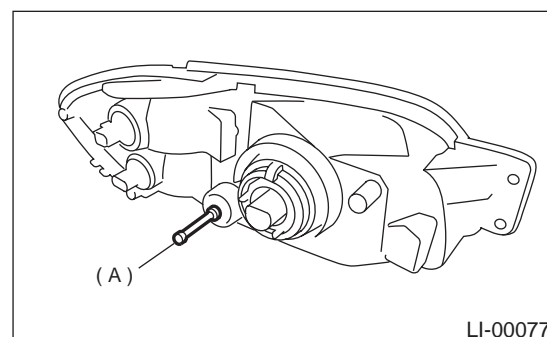

HEADLIGHT ASSEMBLY

LIGHTING SYSTEM

Dual-bulb type

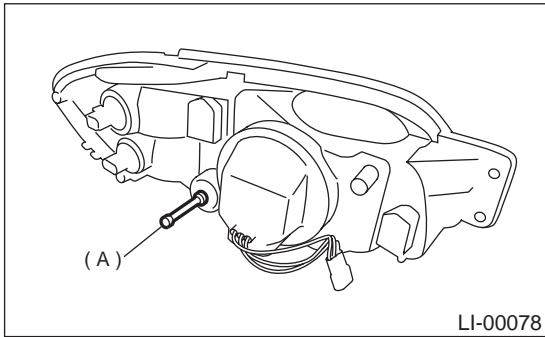

HEADLIGHT ASSEMBLY

LIGHTING SYSTEM

Single-bulb headlight

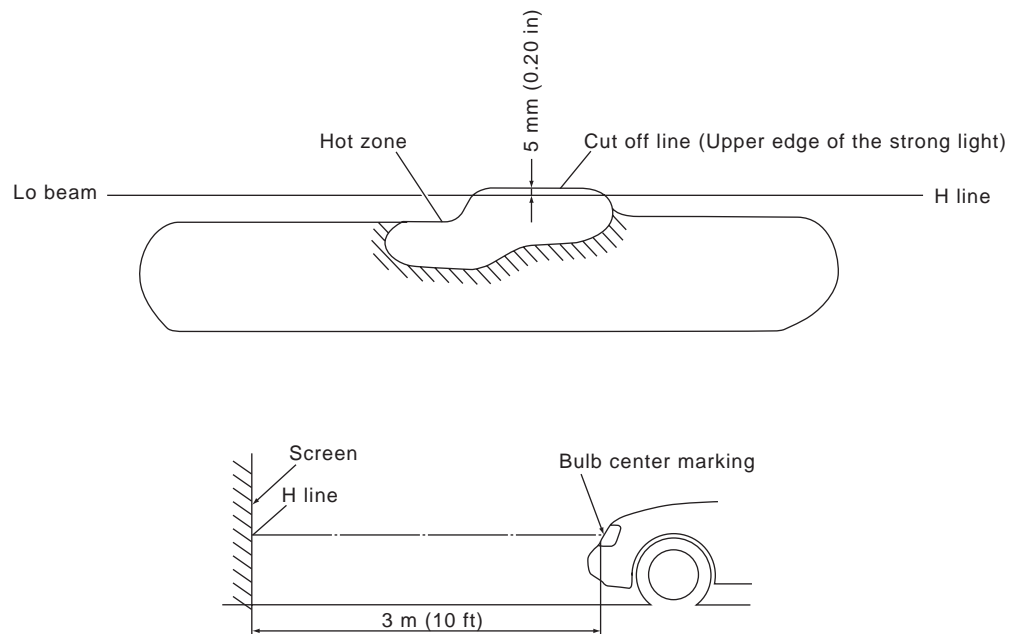

Dual-bulb headlight

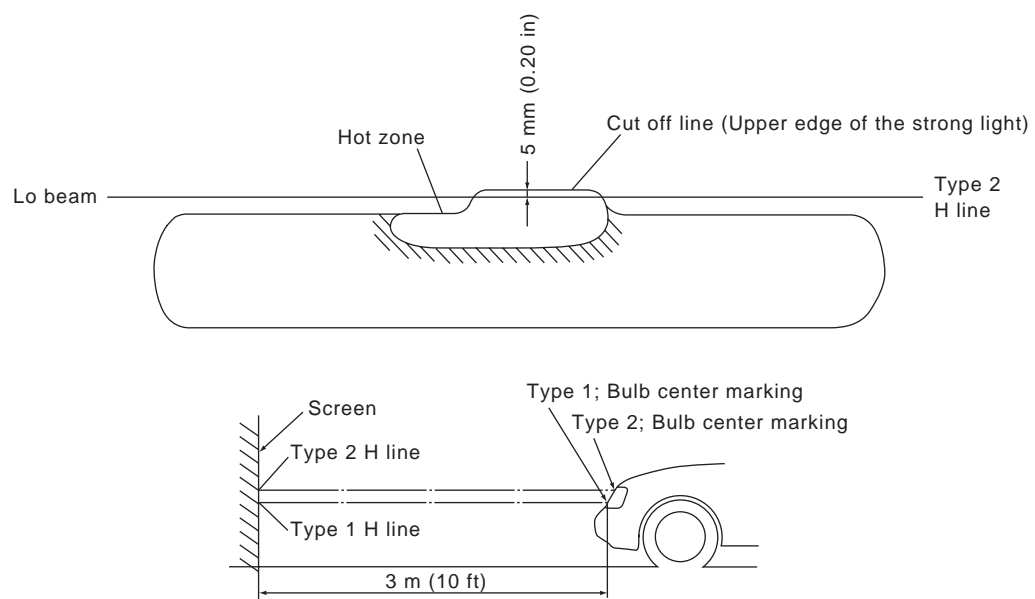

LI-00079