

## BUTTON ASSEMBLY

OnStar (R)

---

### 4. Button Assembly

#### A: REMOVAL

- 1) Disconnect the ground cable from battery.
- 2) Remove meter visor. <Ref. to IDI-12, REMOVAL, Combination Meter Assembly.>
- 3) Remove audio body. <Ref. to ET-5, REMOVAL, Radio Body.>
- 4) Remove button assembly from the audio body.

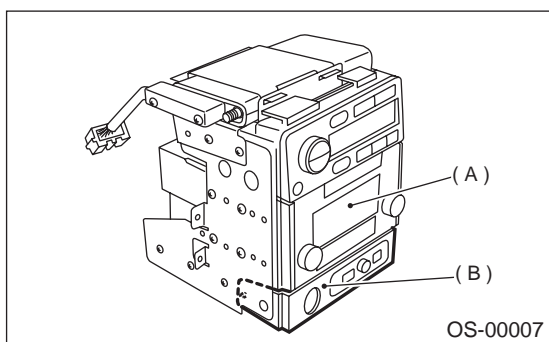

- (A) Audio body  
(B) Button ASSY

#### B: INSTALLATION

Install in the reverse order of removal.

#### **Tightening torque:**

**4.6 N·m (0.47 kgf-m, 3.4 ft-lb)**