

## FRONT SEAT BELT

SEAT BELT SYSTEM

### 3. Front Seat Belt

#### A: REMOVAL

##### 1. OUTER BELT (FRONT)

- 1) Fold backrest all the way forward, and then move front seat all the way forward.
- 2) Turn ignition switch OFF, disconnect ground cable from battery, and wait for more than 20 seconds before starting work.
- 3) Remove center pillar lower trim. <Ref. to EI-42, REMOVAL, Lower Inner Trim.>
- 4) Remove webbing guide.

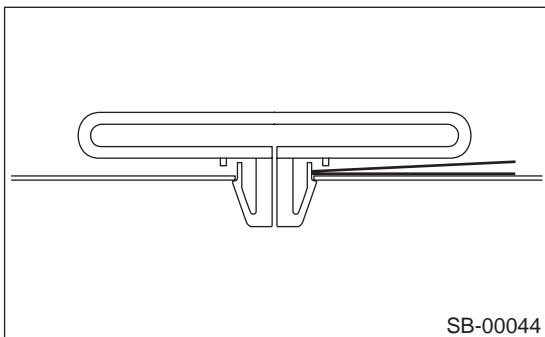
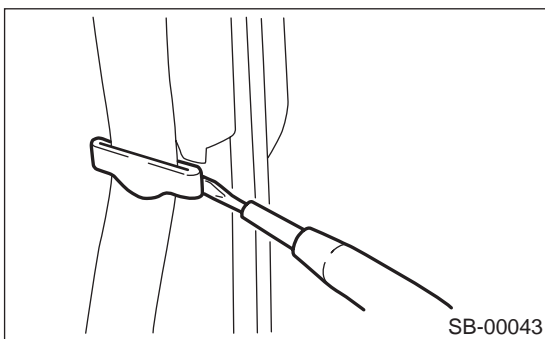

- 5) Remove anchor cover. Loosen shoulder anchor bolt, and then detach shoulder anchor from center pillar.

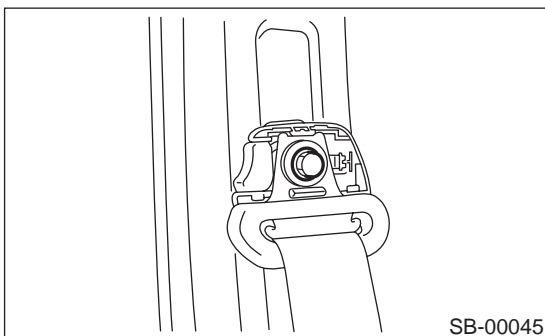

- 6) Turn over the floor mat to remove bolt.

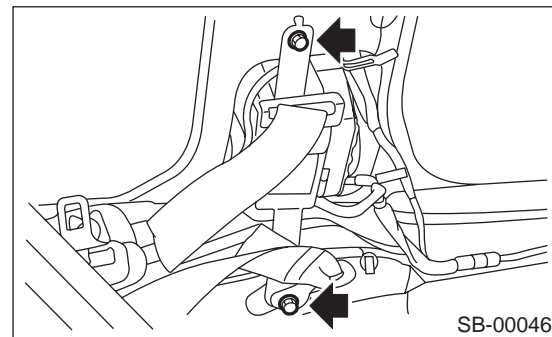

- 7) Disconnect yellow connector of pretensioner harness, and remove outer belt (front).

#### CAUTION:

- Do not drop or apply any impact to pretensioner.
- Pretensioner and bracket should be treated as an assembly. Do not attempt to disassemble it.

##### 2. INNER BELT (FRONT)

- 1) Disconnect connector.
- 2) Remove anchor bolt, and then detach inner belt.

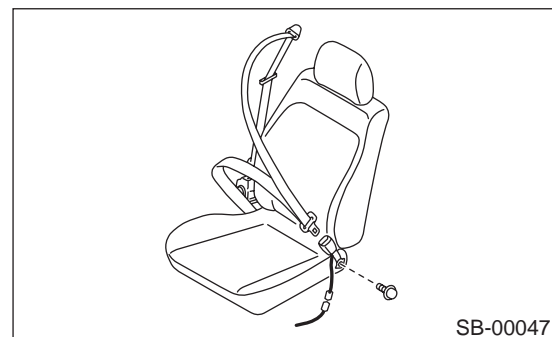

## FRONT SEAT BELT

SEAT BELT SYSTEM

---

### B: INSTALLATION

#### 1. OUTER BELT (FRONT)

Install in the reverse order of removal.

**CAUTION:**

- The parts on left and right are not identical. Before installation, make sure that the correct part is used.
- Be careful not to twist belts during installation.

#### 2. INNER BELT (FRONT)

Install in the reverse order of removal.

**Tightening torque:**

*Refer to COMPONENT in General Description, <Ref. to SB-2, FRONT SEAT BELT, COMPONENT, General Description.>.*

### C: INSPECTION

#### 1. OUTER BELT (FRONT)

Check for the following, and replace with new parts if necessary.

- Pretensioner is cracked or deformed.
- Seat belt is slackened, bent, or frayed. Seat belt is abnormally wound or extended.

#### 2. INNER BELT (FRONT)

Check for the following, and replace with new parts if necessary.

- Inner belt is deformed or damaged.
- Seat belt buckle is engaged improperly.