

## REAR SEAT BELT

SEAT BELT SYSTEM

### 4. Rear Seat Belt

#### A: REMOVAL

##### 1. OUTER BELT SIDE (SEDAN BODY)

- 1) Remove rear shelf trim. <Ref. to EI-48, REMOVAL, Rear Shelf Trim.>
- 2) Remove side sill rear upper cover. <Ref. to EI-42, REMOVAL, Lower Inner Trim.>
- 3) Remove bolts, then detach outer belt side.

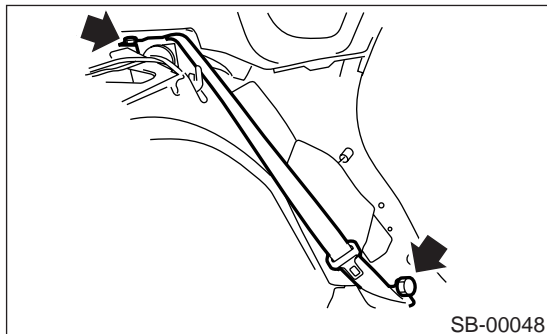

##### 2. OUTER BELT CENTER (SEDAN BODY)

- 1) Remove rear shelf trim. <Ref. to EI-48, REMOVAL, Rear Shelf Trim.>
- 2) Remove bolt, and then detach outer belt center.

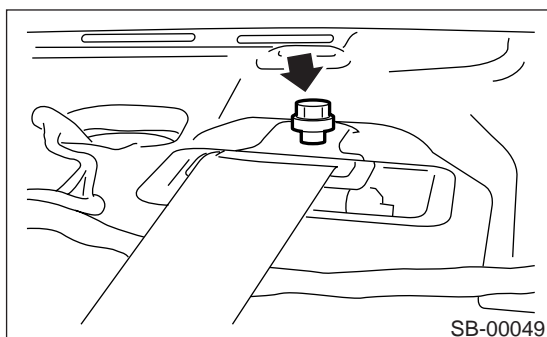

##### 3. INNER BELT (SEDAN BODY)

- 1) Remove the rear cushion. <Ref. to SE-17, REMOVAL, Rear Seat.>
- 2) Remove bolts, and then detach inner belt.

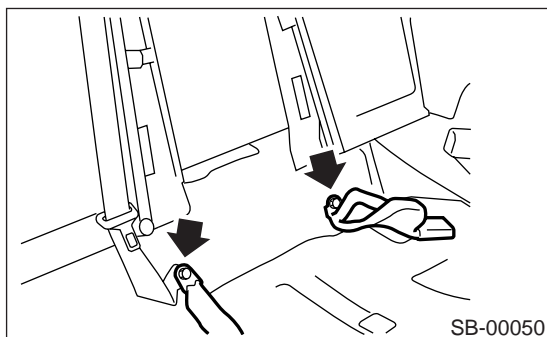

##### 4. OUTER BELT SIDE (WAGON BODY)

- 1) Remove rear quarter trim. <Ref. to EI-43, WAGON, REMOVAL, Rear Quarter Trim.>
- 2) Remove rear quarter upper trim. <Ref. to EI-41, REMOVAL, Upper Inner Trim.>
- 3) Remove bolt and nut, and then detach outer belt side.

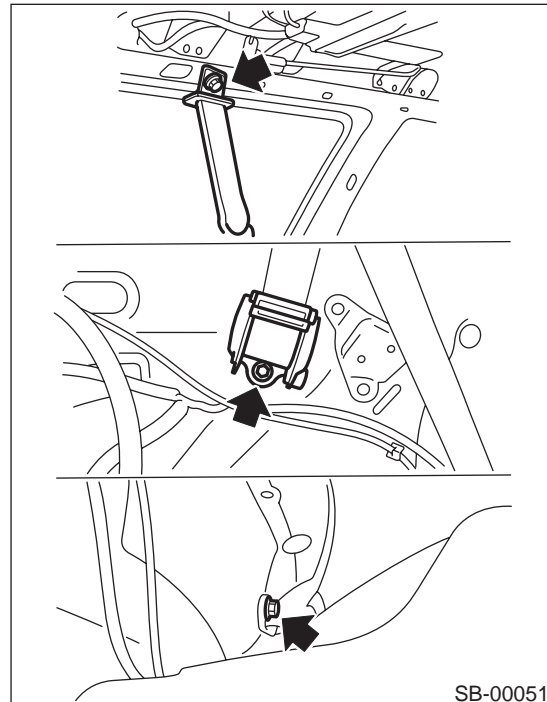

## REAR SEAT BELT

### SEAT BELT SYSTEM

#### 5. OUTER BELT CENTER (WAGON BODY)

##### CAUTION:

When removing clip, use great care not to damage the roof trim.

- 1) Remove luggage room light. <Ref. to LI-28, REMOVAL, Luggage Room Light.>
- 2) Remove rear mole (A) of right side.
- 3) Remove screws (B) and clips (C) of rear quarter lower trim shown in the figure.
- 4) Remove rear quarter upper trim (D) of right side.
- 5) Remove rear rail trim (E).

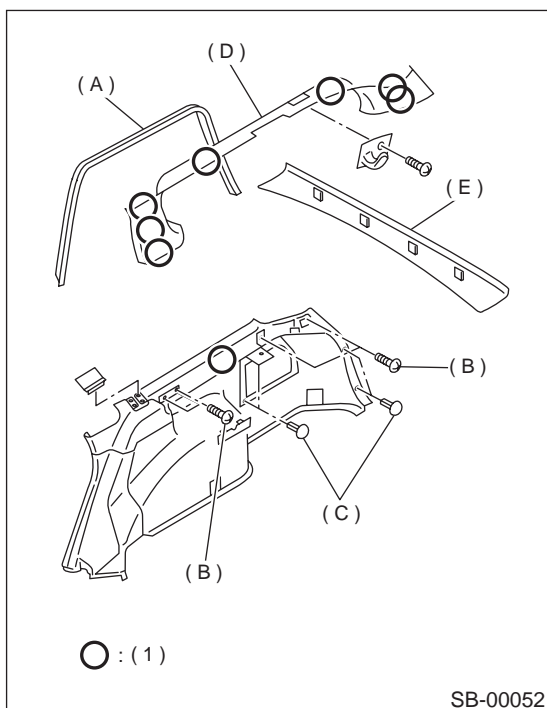

- (1) Hook pawl

6) Remove cover (B) while detaching snap lock carefully. Put the outer belt center tongue (A) out to the other side of the trim through the hole.

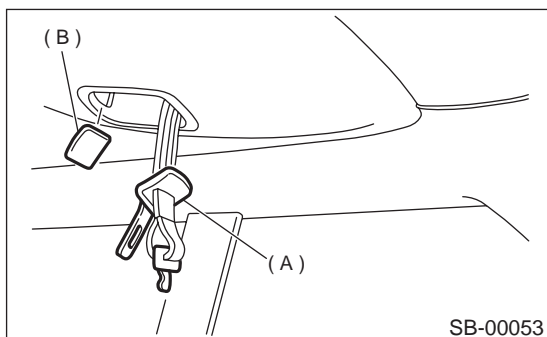

7) Remove clips and hang down rear end of roof trim.

8) Disconnect harness and connector, and then remove outer belt center assembly.

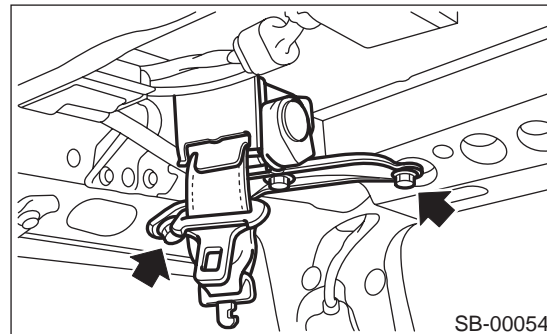

#### 6. INNER BELT (WAGON BODY)

- 1) Raise the rear cushion.
- 2) Remove bolt, and then detach inner belt.

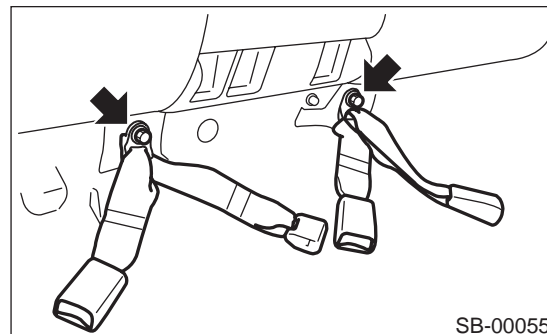

**B: INSTALLATION**

**1. OUTER BELT SIDE (SEDAN BODY)**

Install in the reverse order of removal.

**CAUTION:**

- During installation, make sure that seat belts are not twisted.
- After installation, make sure that seat belts can be smoothly extended and wound.

**2. OUTER BELT CENTER (SEDAN BODY)**

Install in the reverse order of removal.

**CAUTION:**

- During installation, make sure that seat belts are not twisted.
- After installation, make sure that seat belts can be smoothly extended and wound.

**3. INNER BELT (SEDAN BODY)**

Install in the reverse order of removal.

**CAUTION:**

During installation, make sure that seat belts are not twisted.

**4. OUTER BELT SIDE (WAGON BODY)**

Install in the reverse order of removal.

**CAUTION:**

- During installation, make sure that seat belts are not twisted.
- After installation, make sure that seat belts can be smoothly extended and wound.

**5. OUTER BELT CENTER (WAGON BODY)**

Install in the reverse order of removal.

**CAUTION:**

- During installation, make sure that seat belts are not twisted.
- After installation, make sure that seat belts are smoothly extended and wound.

**6. INNER BELT (WAGON BODY)**

Install in the reverse order of removal.

**CAUTION:**

During installation, make sure that seat belts are not twisted.

**Tightening torque:**

*Refer to COMPONENT in General Description. <Ref. to SB-3, REAR SEAT BELT (SEDAN BODY), COMPONENT, General Description.> or <Ref. to SB-4, REAR SEAT BELT (WAGON BODY), COMPONENT, General Description.>*

**C: INSPECTION**

**1. OUTER BELT SIDE (SEDAN BODY)**

Check for the following, and replace with new parts if necessary.

- Seat belt is slackened, bent, or frayed. Seat belt is abnormally wound or extended.

**2. OUTER BELT CENTER (SEDAN BODY)**

Check for the following, and replace with new parts if necessary.

- Seat belt is slackened, bent, or frayed. Seat belt is abnormally wound or extended.

**3. INNER BELT (SEDAN BODY)**

Check for the following, and replace with new parts if necessary.

- Inner belt is deformed or damaged.
- Seat belt buckle is engaged improperly.

**4. OUTER BELT SIDE (WAGON BODY)**

Check for the following, and replace with new parts if necessary.

- Seat belt is slackened, bent, or frayed. Seat belt is abnormally wound or extended.

**5. OUTER BELT CENTER (WAGON BODY)**

Check for the following, and replace with new parts if necessary.

- Seat belt is slackened, bent, or frayed. Seat belt is abnormally wound or extended.

**6. INNER BELT (WAGON BODY)**

Check for the following, and replace with new parts if necessary.

- Inner belt is deformed or damaged.
- Seat belt buckle is engaged improperly.

## REAR SEAT BELT

SEAT BELT SYSTEM

---

**MEMO:**