

20. Ignition Key Lock

A: REPLACEMENT

- 1) Disconnect ground cable from battery.
- 2) Remove the steering column. <Ref. to PS-21, REMOVAL, Tilt Steering Column.>
- 3) Secure the steering column in a vise. Remove the bolt with a drill.

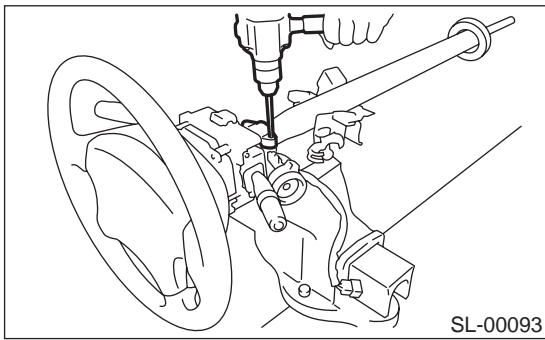

- 4) Remove the ignition key lock.
- 5) Use a new torn bolt. Tighten the torn bolt to the end of the thread.

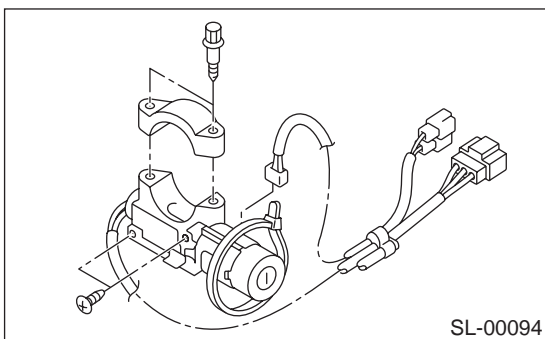

B: INSPECTION

- 1) Remove the instrument panel lower cover.
- 2) Remove the lower column cover.
- 3) Unfasten the hold-down clip which secures the harness and disconnect the connector of the ignition switch from the body harness.
- 4) Turn the ignition key plate to each position and check the continuity between the terminals of the ignition connector.

Switch position	Terminal No.	Standard
LOCK	—	—
ACC	No. 1 and No. 2	Less than 1 Ω
ON	No. 1 and No. 2 No. 1 and No. 4 No. 2 and No. 4	Less than 1 Ω
ST	No. 1 and No. 3 No. 1 and No. 4 No. 3 and No. 4	Less than 1 Ω

If NG, replace the ignition switch.