

GENERAL DESCRIPTION

ABS

1. General Description

A: SPECIFICATIONS

Item			Standard or remarks	
ABS sensor	ABS sensor gap	Front	0.3 — 0.8 mm (0.012 — 0.031 in)	
		Rear	0.44 — 0.94 mm (0.0173 — 0.0370 in)	
	ABS sensor resistance		1.25±0.25 kΩ	
	Marks of the harness	Front LH	Except OUTBACK	Yellow
			OUTBACK	Brown
		Front RH	Except OUTBACK	White
			OUTBACK	Light blue
		Rear LH		Yellow
Rear RH		White		
G sensor	G sensor voltage		2.3±0.2 V	
ABS control module and hydraulic control unit (ABSCM&H/U) marks	AT (Except OUTBACK)		CG	
	MT (Except OUTBACK)		CH	
	AT (OUTBACK)		CI	
	MT (OUTBACK)		CJ	

ABS-2

GENERAL DESCRIPTION

ABS

B: COMPONENT

1. SENSOR

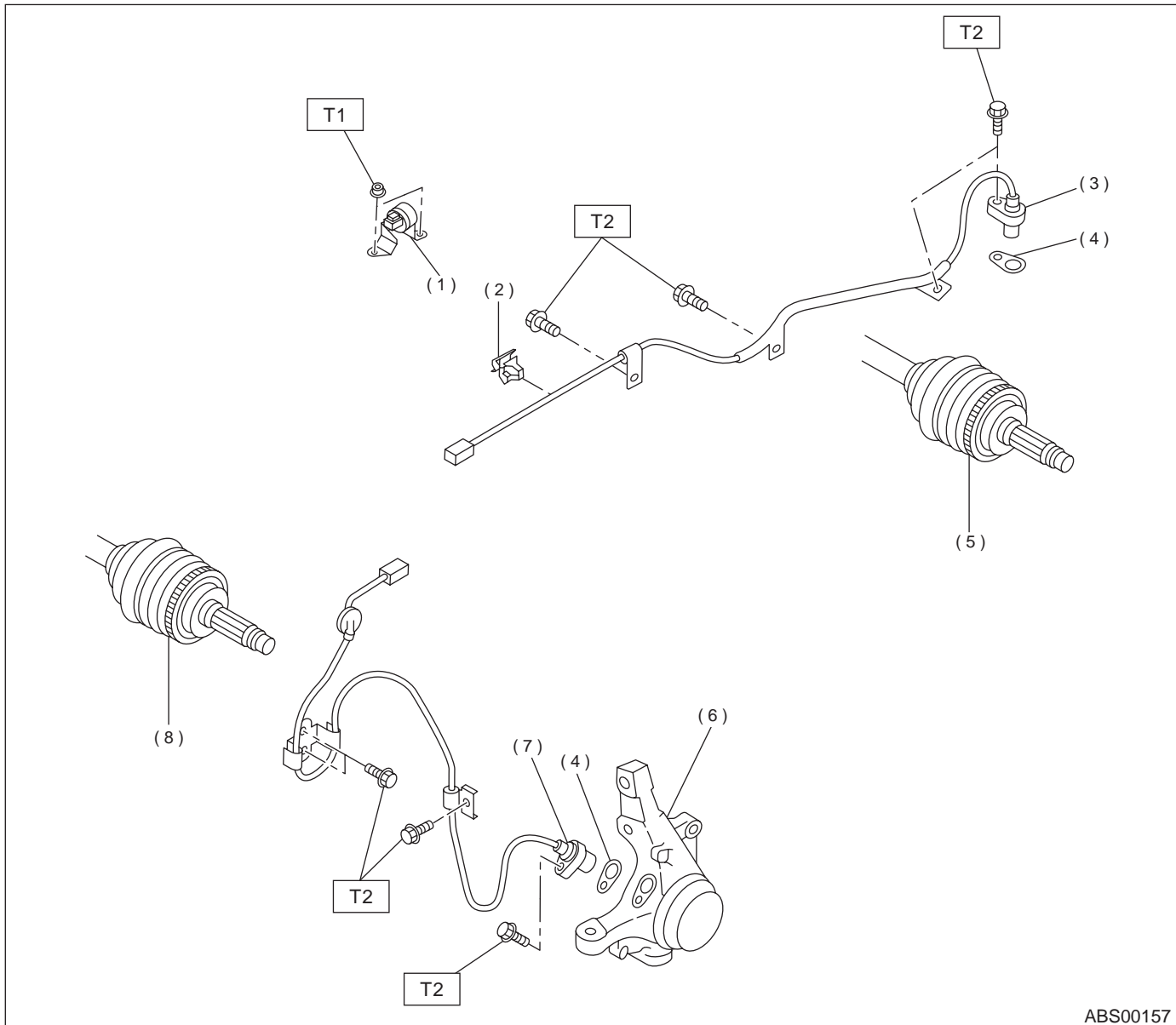

- (1) G sensor
- (2) Clip
- (3) Rear ABS sensor LH
- (4) ABS spacer

- (5) Tone wheel (Rear)
- (6) Housing
- (7) Front ABS sensor LH
- (8) Tone wheel (Front)

Tightening torque: N.m (kgf-m, ft-lb)

T1: 7.4 (0.75, 5.4)

T2: 32 (3.3, 24)

ABS-3

GENERAL DESCRIPTION

ABS

2. ABS CONTROL MODULE AND HYDRAULIC CONTROL UNIT (ABSCM&H/U)

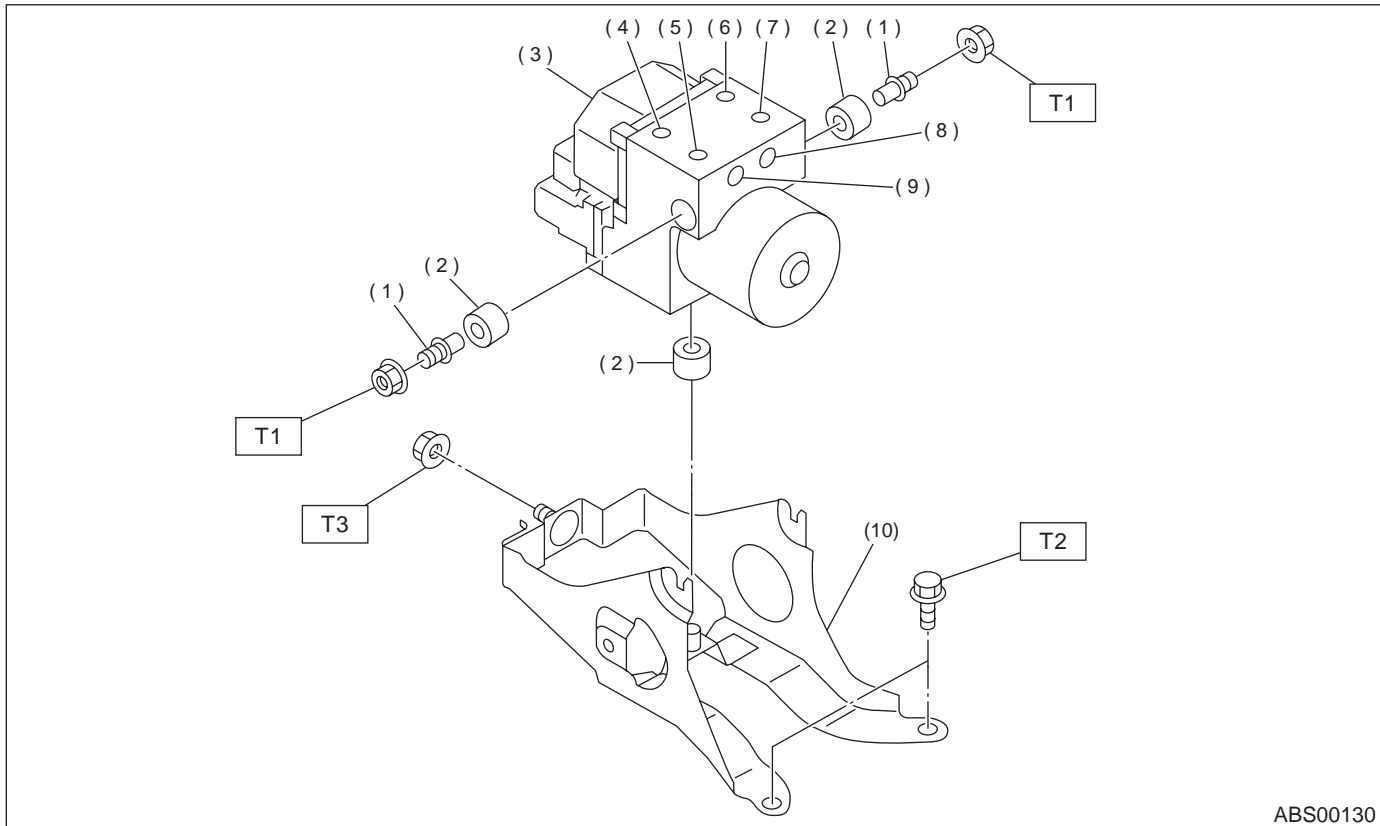

ABS00130

- | | |
|---|---------------------|
| (1) Stud bolt | (6) Front-RH outlet |
| (2) Damper | (7) Primary inlet |
| (3) ABS control module and hydraulic control unit | (8) Rear-LH outlet |
| (4) Front-LH outlet | (9) Rear-RH outlet |
| (5) Secondary inlet | (10) Bracket |

Tightening torque: N·m (kgf-m, ft-lb)

T1: 18 (1.8, 13.06)

T2: 32 (3.3, 24)

T3: 38 (3.9, 28)

ABS-4

GENERAL DESCRIPTION

ABS



C: CAUTION

- Wear working clothing, including a cap, protective goggles, and protective shoes during operation.
- Remove contamination including dirt and corrosion before removal, installation or disassembly.
- Keep the disassembled parts in order and protect them from dust or dirt.
- Before removal, installation or disassembly, be sure to clarify the failure. Avoid unnecessary removal, installation, disassembly, and replacement.

- Be careful not to burn your hands, because each part in the vehicle is hot after running.
- Be sure to tighten fasteners including bolts and nuts to the specified torque.
- Place shop jacks or safety stands at the specified points.
- Before disconnecting electrical connectors of sensors or units, be sure to disconnect ground cable from battery.

D: PREPARATION TOOL

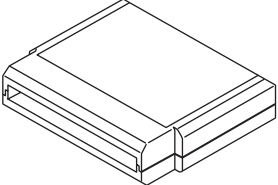
1. SPECIAL TOOLS

ILLUSTRATION	TOOL NUMBER	DESCRIPTION	REMARKS
 ST24082AA210	24082AA210	CARTRIDGE	Troubleshooting for electrical systems.
 ST22771AA030	22771AA030	SELECT MONITOR KIT	Troubleshooting for electrical systems. <ul style="list-style-type: none"> • English: 22771AA030 (Without printer) • German: 22771AA070 (Without printer) • French: 22771AA080 (Without printer) • Spanish: 22771AA090 (Without printer)

2. GENERAL PURPOSE TOOLS

TOOL NAME	REMARKS
Circuit Tester	Used for measuring resistance, voltage and ampere.
Pressure Gauge	Used for measuring oil pressure.
Oscilloscope	Used for measuring sensor.

ABS-5