

ABS CONTROL MODULE AND HYDRAULIC CONTROL UNIT (ABSCM&H/U)

ABS

2. ABS Control Module and Hydraulic Control Unit (ABSCM&H/U)

A: REMOVAL

- 1) Disconnect ground cable from battery.
- 2) Remove air intake duct from engine compartment to facilitate removal of ABSCM&H/U.
- 3) Use an air gun to get rid of water around the ABSCM&H/U.

CAUTION:

The contact will be insufficient if the terminal gets wet.

- 4) Pull off the lock of the ABSCM&H/U connector to remove it.

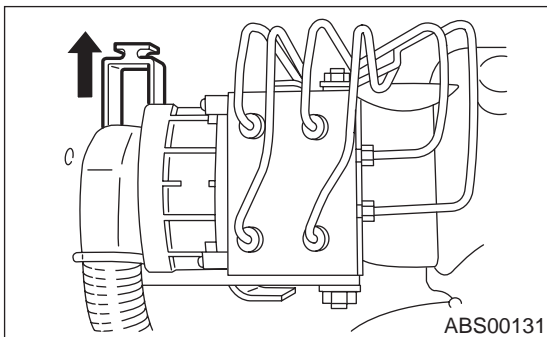

- 5) Disconnect connector from ABSCM&H/U.

CAUTION:

Be careful not to let water or other foreign matter contact the ABSCM&H/U terminal.

- 6) Unlock cable clip.
- 7) Disconnect brake pipes from ABSCM&H/U.

CAUTION:

Wrap brake pipes with vinyl bag to avoid spilling brake fluid on vehicle body.

- 8) Remove ABSCM&H/U ground terminal from bracket.

- 9) Remove ABSCM&H/U from engine compartment.

CAUTION:

- ABSCM&H/U cannot be disassembled. Do not attempt to loosen bolts and nuts.
- Do not drop or bump ABSCM&H/U.
- Do not turn the ABSCM&H/U upside down or place it on its side.
- Be careful to prevent foreign particles from getting into ABSCM&H/U.
- Apply a coat of rust-preventive wax (Nippeco LT or GB) to bracket attaching bolt after tightening.
- Do not pull harness when disconnecting connector.

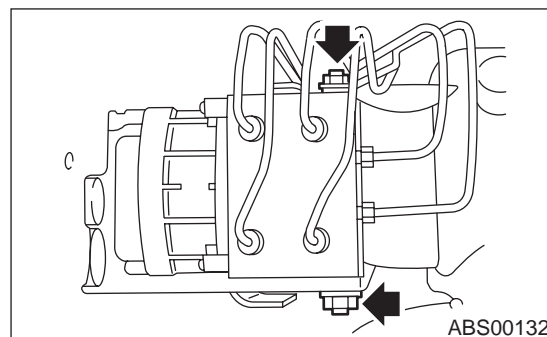

B: INSTALLATION

- 1) Install ABSCM&H/U.

CAUTION:

Confirm that the specifications of the ABSCM&H/U conforms to the vehicle specifications.

Tightening torque:

18 N·m (1.8 kgf·m, 13.0 ft·lb)

- 2) Install ABSCM&H/U ground terminal to bracket.

Tightening torque:

32 N·m (3.3 kgf·m, 24 ft·lb)

- 3) Connect brake pipes to their correct ABSCM&H/U connections.

Tightening torque:

15 N·m (1.5 kgf·m, 10.8 ft·lb)

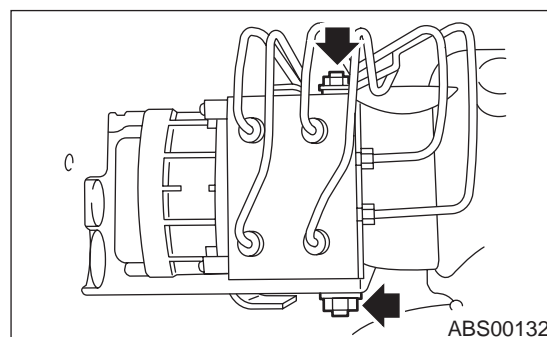

ABS-6

ABS CONTROL MODULE AND HYDRAULIC CONTROL UNIT (ABSCM&H/U)

ABS

- 4) Using cable clip, secure ABSCM&H/U harness to bracket.
- 5) Connect connector to ABSCM&H/U.

CAUTION:

- Be sure to remove all foreign matter from inside the connector before connecting.
- Ensure that the ABSCM&H/U connector is securely locked.

- 6) Install air intake duct.
- 7) Connect ground cable to battery.
- 8) Bleed air from the brake system.

C: INSPECTION

- 1) Check connected and fixed condition of connector.
- 2) Check specifications of the mark with ABSCM&H/U.

Mark	Model
CG	AT (Except OUTBACK)
CH	MT (Except OUTBACK)
CI	AT (OUTBACK)
CJ	MT (OUTBACK)

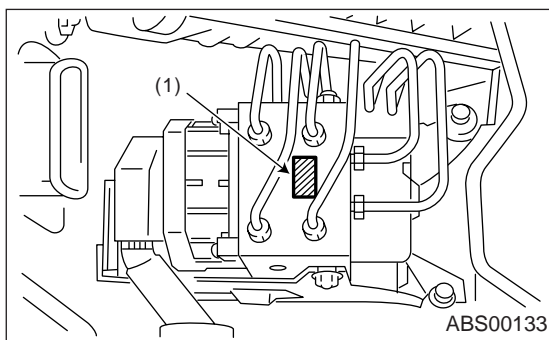

(1) Mark

1. CHECKING THE HYDRAULIC UNIT ABS OPERATION BY PRESSURE GAUGE

- 1) Lift-up vehicle and remove wheels.
- 2) Disconnect the air bleeder screws from the FL and FR caliper bodies.
- 3) Connect two pressure gauges to the FL and FR caliper bodies.

CAUTION:

- Pressure gauges used exclusively for brake fluid must be used.
- Do not employ pressure gauge previously used for transmission since the piston seal is expanded which may lead to malfunction of the brake.

NOTE:

Wrap sealing tape around the pressure gauge.

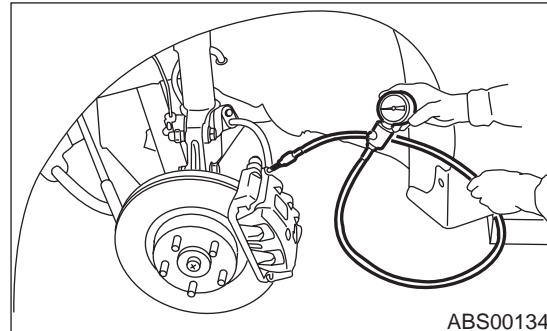

ABS00134

- 4) Bleed air from the pressure gauges.
- 5) Perform ABS sequence control.
<Ref. to ABS-9, ABS Sequence Control.>
- 6) When the hydraulic unit begins to work, and first the FL side performs decompression, holding, and compression, and then the FR side performs decompression, holding, and compression.
- 7) Read values indicated on the pressure gauge and check if the fluctuation of the values between decompression and compression meets the standard values. Also check if any irregular brake pedal tightness is felt.

	Front wheel	Rear wheel
Initial value	3,432 kPa (35 kg/cm ² , 498 psi)	3,432 kPa (35 kg/cm ² , 498 psi)
When decompressed	490 kPa (5 kg/cm ² , 71 psi) or less	490 kPa (5 kg/cm ² , 71 psi) or less
When compressed	3,432 kPa (35 kg/cm ² , 498 psi) or more	3,432 kPa (35 kg/cm ² , 498 psi) or more

- 8) Remove pressure gauges from FL and FR caliper bodies.
- 9) Remove air bleeder screws from the RL and RR caliper bodies.
- 10) Connect the air bleeder screws to the FL and FR caliper bodies.
- 11) Connect two pressure gauges to the RL and RR caliper bodies.
- 12) Bleed air from the pressure gauges and the FL and FR caliper bodies.
- 13) Perform ABS sequence control.
<Ref. to ABS-9, ABS Sequence Control.>
- 14) When the hydraulic unit begins to work, at first the RR side performs decompression, holding, and compression, and then the RL side performs decompression, holding, and compression.
- 15) Read values indicated on the pressure gauges and check if they meet the standard value.
- 16) After checking, remove the pressure gauges from caliper bodies.

ABS-7

ABS CONTROL MODULE AND HYDRAULIC CONTROL UNIT (ABSCM&H/U)

ABS

- 17) Connect the air bleeder screws to RL and RR caliper bodies.
- 18) Bleed air from brake line.

2. CHECKING THE HYDRAULIC UNIT ABS OPERATION WITH BRAKE TESTER

- 1) In the case of AWD AT vehicles, install a spare fuse with the FWD connector in the main fuse box to simulate FWD vehicles.

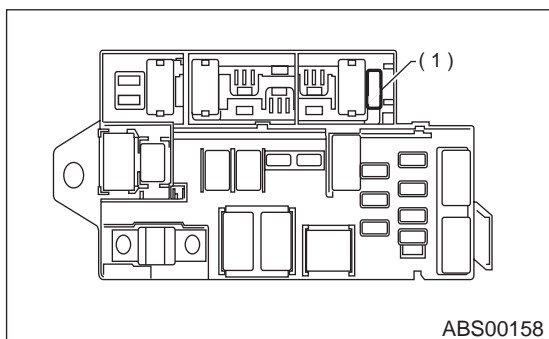

(1) FWD connector

- 2) Prepare for operating ABS sequence control. <Ref. to ABS-9, ABS Sequence Control.>
- 3) Set the front wheels or rear wheels on the brake tester and set the select lever's position at "neutral".

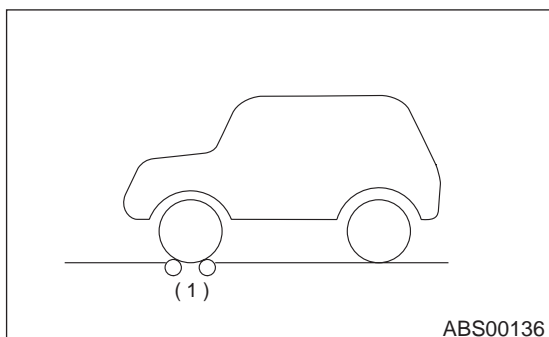

(1) Brake tester

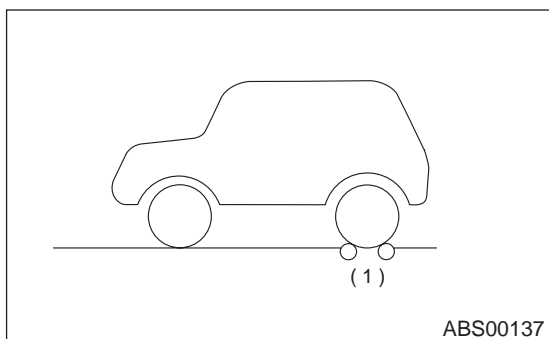

(1) Brake tester

- 4) Operate the brake tester.
- 5) Perform ABS sequence control. <Ref. to ABS-9, ABS Sequence Control.>
- 6) Hydraulic unit begins to work; and check the following working sequence.
 - (1) The FL wheel performs decompression, holding, and compression in sequence, and subsequently the FR wheel repeats the cycle.
 - (2) The RR wheel performs decompression, holding, and compression in sequence, and subsequently the RL wheel repeats the cycle.
- 7) Read values indicated on the brake tester and check if the fluctuation of values, when decompressed and compressed, meet the standard values.

	Front wheel	Rear wheel
Initial value	981 N (100 kgf, 221 lb)	981 N (100 kgf, 221 lb)
When decompressed	490 N (50 kgf, 110 lb) or less	490 N (50 kgf, 110 lb) or less
When compressed	981 N (100 kgf, 221 lb) or more	981 N (100 kgf, 221 lb) or more

- 8) After checking, also check if any irregular brake pedal tightness is felt.

ABS-8