

FRONT DISC BRAKE ASSEMBLY

BRAKE

4. Front Disc Brake Assembly

A: REMOVAL

- 1) Loosen wheel nuts, jack-up vehicle, support it with safety stands, and remove wheel.
- 2) Remove union bolt and disconnect brake hose from caliper body assembly.

CAUTION:

Do not spill brake fluid on painted surface.
Wash it off immediately.

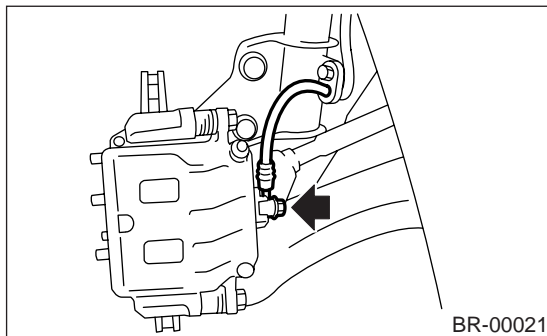

- 3) Remove bolt securing lock pin to caliper body.

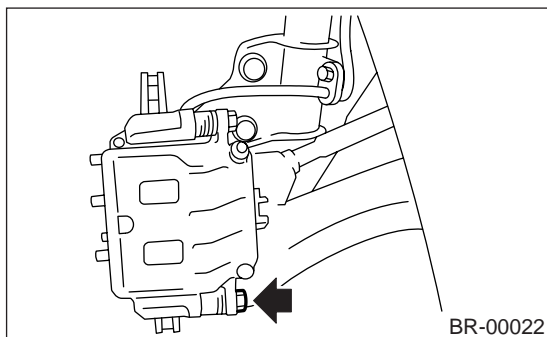

- 4) Raise caliper body and move it toward vehicle center to separate it from support.
- 5) Remove support from housing.

NOTE:

Remove support only when replacing it or the rotor. It need not be removed when servicing caliper body assembly.

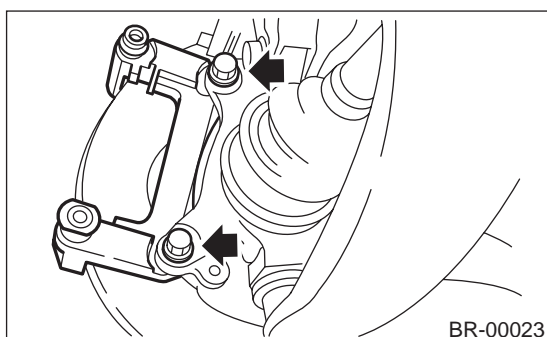

- 6) Remove disc rotor from hub.

NOTE:

If disc rotor seizes up within hub, drive disc rotor out by installing an 8-mm bolt in holes B on the rotor.

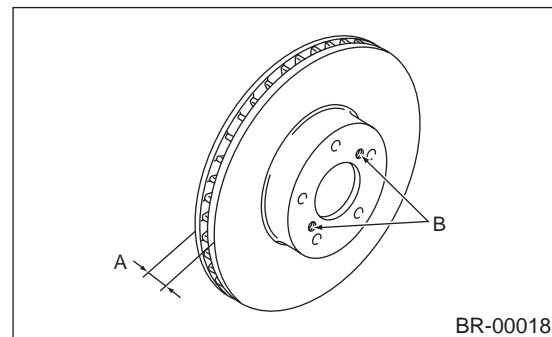

- 7) Clean mud and foreign particles from caliper body assembly and support.

B: INSTALLATION

- 1) Install disc rotor on hub.
- 2) Install support on housing.

Tightening torque:

78 N·m (8 kgf·m, 58 ft·lb)

CAUTION:

- Always replace the pads for both the left and right wheels at the same time. Also replace pad clips if they are twisted or worn.
- A wear indicator is provided on the inner disc brake pad. If the pad wears down to such an extent that the end of the wear indicator contacts the disc rotor, a squeaking sound is produced as the wheel rotates. If this sound is heard, replace the pad.

- When replacing the pads, replace pads of the right and left wheels at the same time.

- 3) Apply thin coat of Molykote AS880N (Part No. 26298AC000) to the frictional portion between pad and pad clip.

- 4) Apply thin coat of Molykote AS880N (Part No. 26298AC000) to the frictional portion between pad and inner shim.

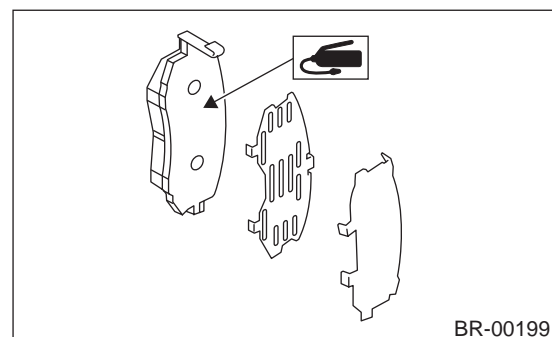

- 5) Install pads on support.

BR-16

FRONT DISC BRAKE ASSEMBLY

BRAKE

6) Install caliper body on support.

Tightening torque:

39 N·m (4.0 kgf·m, 28.9 ft·lb)

7) Connect brake hose.

Tightening torque:

18 N·m (1.8 kgf·m, 13.0 ft·lb)

CAUTION:

Replace brake hose gaskets with new ones.

8) Bleed air from brake system.

C: DISASSEMBLY

1) Clean mud and foreign particles from the caliper body assembly and support.

CAUTION:

Be careful not to allow foreign particles to enter inlet (at brake hose connector).

2) Remove the boot from piston end.

3) Place a wooden block as shown in the figure to prevent damage to the piston. Gradually supply compressed air via inlet of the brake hose to force piston out.

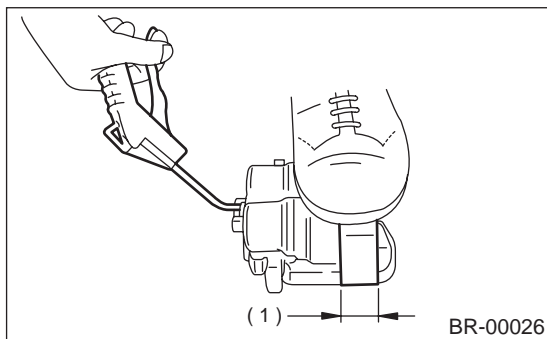

(1) Place a 30 mm (1.18 in) wide wooden block here.

4) Remove the piston seal from caliper body cylinder.

CAUTION:

Be careful not to scratch the inner surface of cylinder and piston seal groove.

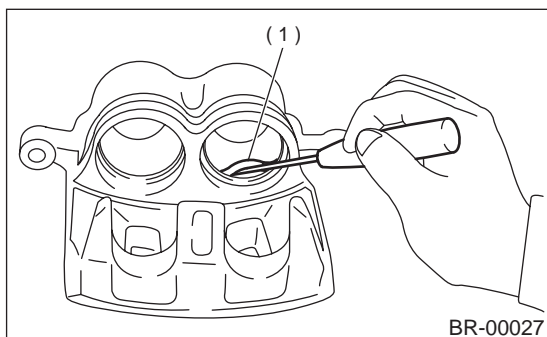

(1) Piston seal

5) Remove the lock pin boot and guide pin boot.

D: ASSEMBLY

1) Clean the caliper body interior using brake fluid.

2) Apply a coat of brake fluid to the piston seal and fit piston seal in groove on caliper body.

3) Apply a coat of brake fluid to the entire inner surface of cylinder and outer surface of piston.

4) Apply a coat of specified grease to the boot and fit in groove on ends of cylinder and piston.

Grease:

NIGLUBE RX-2 (Part No. K0779GA102)

5) Insert the piston into cylinder.

CAUTION:

Do not force the piston into cylinder.

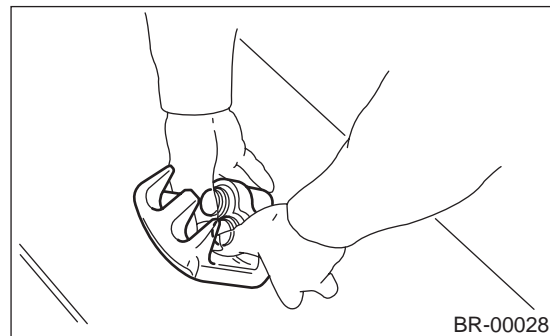

6) Position the boot in grooves on cylinder and piston.

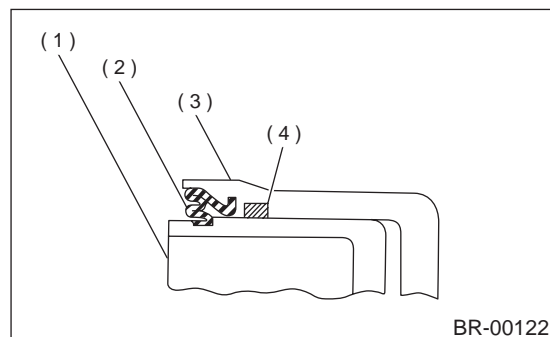

- (1) Piston
- (2) Piston boot
- (3) Caliper body
- (4) Piston seal

BR-17

FRONT DISC BRAKE ASSEMBLY

BRAKE

7) Apply a coat of specified grease to the lock pin and guide pin, outer surface, cylinder inner surface, and boot grooves.

Grease:

NIGLUBE RX-2 (Part No. K0779GA102)

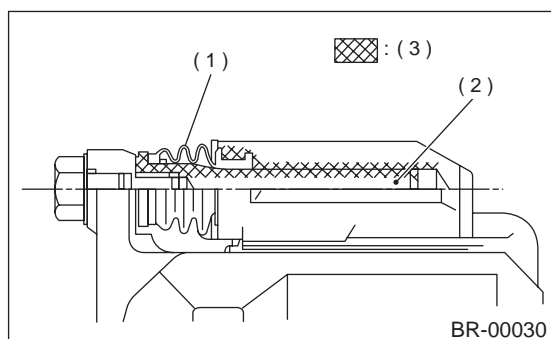

- (1) Pin boot
- (2) Lock pin or guide pin
- (3) Apply grease.

8) Install the lock pin boot and guide pin boot on support.

E: INSPECTION

- 1) Repair or replace the faulty parts.
- 2) Check the caliper body and piston for uneven wear, damage or rust.
- 3) Check the rubber parts for damage or deterioration.

BR-18