

MASTER CYLINDER

BRAKE

8. Master Cylinder

A: REMOVAL

- 1) Thoroughly drain brake fluid from reservoir tank.
- 2) Disconnect fluid level indicator harness connector.
- 3) Remove brake pipes from master cylinder.
- 4) Remove master cylinder mounting nuts, and take out master cylinder from brake booster.

CAUTION:

Be extremely careful not to spill brake fluid. Brake fluid spilt on the vehicle body will harm the painted surface; wash it off quickly if spilt.

B: INSTALLATION

To install the master cylinder to the body, reverse the sequence of removal procedure.

Tightening torque:

Master cylinder mounting nut

14 N·m (1.4 kgf-m, 10.1 ft-lb)

Piping flare nut

15 N·m (1.5 kgf-m, 10.8 ft-lb)

CAUTION:

Be sure to use recommended brake fluid.

C: DISASSEMBLY

1. PRECAUTIONS FOR DISASSEMBLING

- 1) Remove mud and dirt from the surface of brake master cylinder.
- 2) Prepare tools necessary for disassembly operation, and arrange them neatly on work bench.
- 3) Clean work bench.

2. DISASSEMBLING PROCEDURE

- 1) Remove pin with drift pin which secures reserve tank to master cylinder.
- 2) Remove cylinder pin with magnetic pick-up tool while pushing in primary piston.

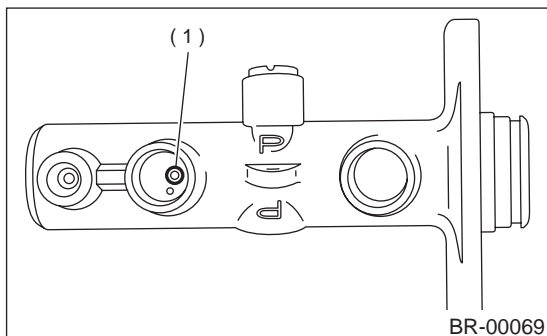

(1) Cylinder pin

- 3) Pry up the pawl and remove the piston retainer. (Without VDC)

NOTE:

Piston may jump out from master cylinder.

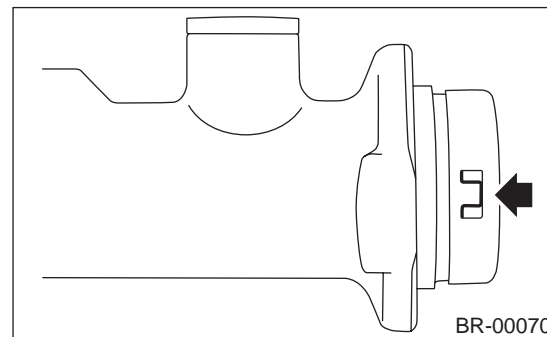

- 4) Using pliers, remove C-ring. (With VDC)

NOTE:

Piston may jump out from master cylinder.

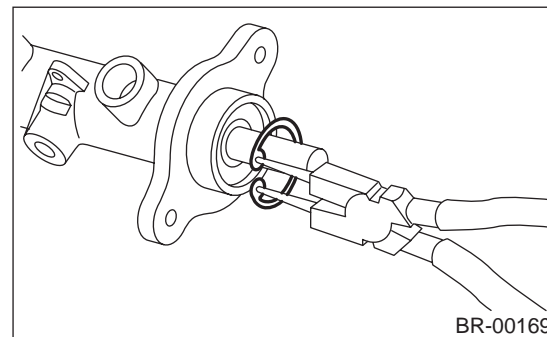

- 5) Extract primary piston assembly and secondary piston assembly.

CAUTION:

- Do not disassemble the piston assembly; otherwise, the spring set value may be changed.
- Use brake fluid or methanol to wash inside wall of cylinder, pistons and piston cups. Be careful not to damage parts when washing. If methanol is used for washing, do not dip rubber parts, such as piston cups, in it for more than 30 seconds; otherwise, they may become swelled.

D: ASSEMBLY

1. PRECAUTIONS FOR ASSEMBLING

- 1) When assembling, be sure to use recommended brake fluid.
- 2) Ensure that the inside wall of cylinder, pistons, and piston cups are free from dirt when assembling.
- 3) Be extremely careful not to damage, scratch, or dent cylinder inside wall, pistons, and piston cups.
- 4) Do not drop parts. Never attempt to use any part that has been dropped accidentally.

BR-25

MASTER CYLINDER

BRAKE

2. ASSEMBLING PROCEDURE

- 1) Assembling piston assembly:
Apply recommended brake fluid to inside wall of cylinder, and to outer surface of piston assembly, and install piston assemblies carefully into cylinder.
- 2) Assembling cylinder pin:
- 3) Press the pawl and install the piston retainer into the master cylinder. (Without VDC)

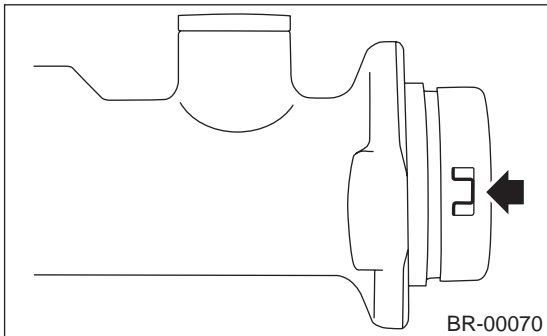

- 4) Using pliers, install C-ring in its groove. (With VDC)

CAUTION:

Make sure to install it firmly to groove.

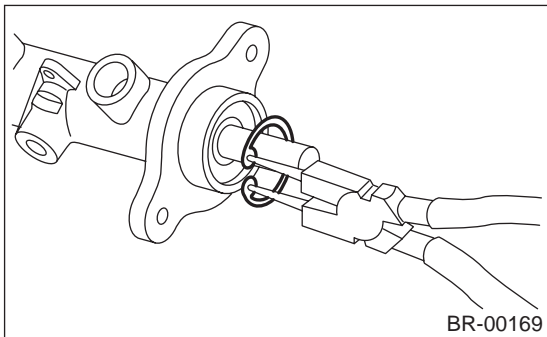

- 5) Install seal to reservoir tank.

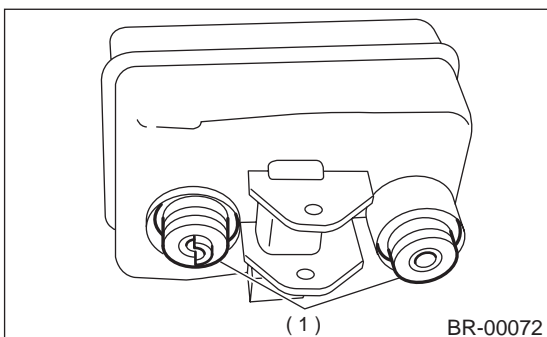

(1) Seal

- 6) Install pin with drift pins which secures reservoir tank to master cylinder.

E: INSPECTION

If any damage, deformation, wear, swelling, rust, and other faults are found on the primary piston assembly, secondary piston assembly, supply valve stopper, or gasket, replace the faulty part.

CAUTION:

- The primary and secondary pistons must be replaced as complete assemblies.
- The service limit of the clearance between each piston and the master cylinder inner dia. is 0.11 mm (0.0043 in).
- When handling parts, be extremely careful not to damage or scratch the parts, or let any foreign matter get on them.

BR-26