

GENERAL DESCRIPTION

DRIVE SHAFT SYSTEM

1. General Description

A: SPECIFICATIONS

1. PROPELLER SHAFT

Propeller shaft type		DOJ type
Front propeller shaft Joint-to-joint length: L ₁ mm (in)	AT	629 (24.76)
	MT	688 (27.09)
Rear propeller shaft Joint-to-joint length: L ₂ mm (in)		773 (30.43)
Outside diameter of tube: mm (in)	D ₁	63.5 (2.500)
	D ₂	57.0 (2.244)

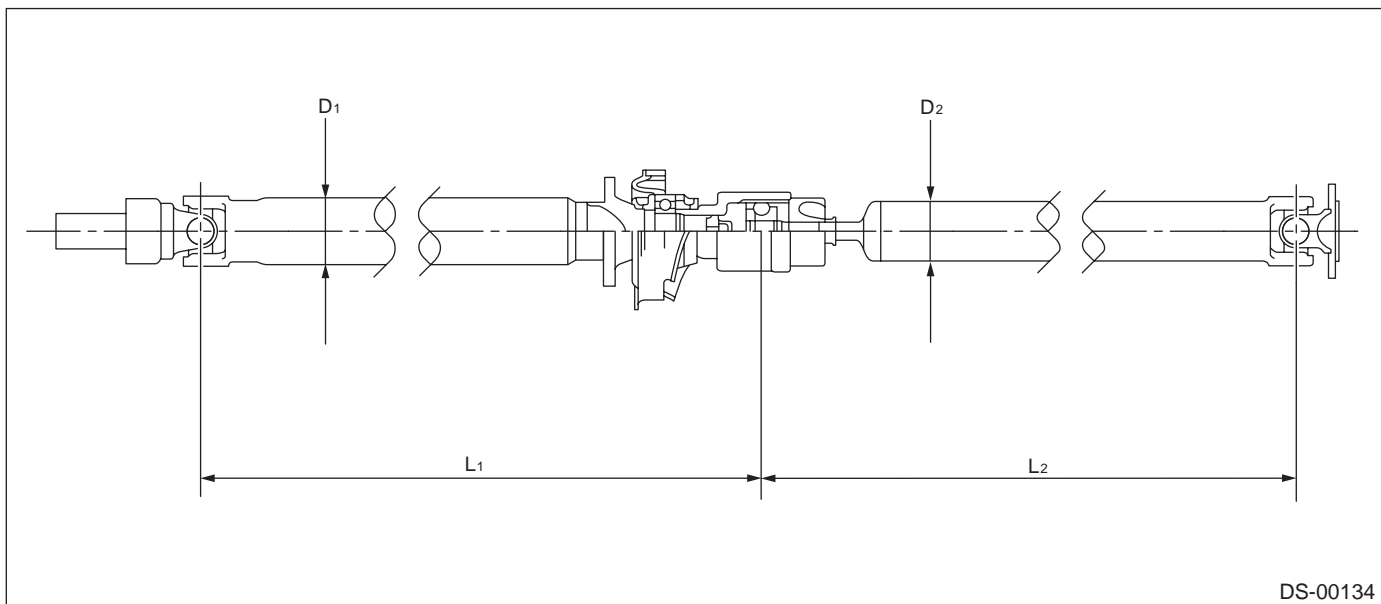

DS-2

GENERAL DESCRIPTION

DRIVE SHAFT SYSTEM

2. FRONT DRIVE SHAFT ASSEMBLY

Type of drive shaft assembly	SHAFT
	Shaft diameter
BJ87+SFJ82	26 mm (1.02 in)

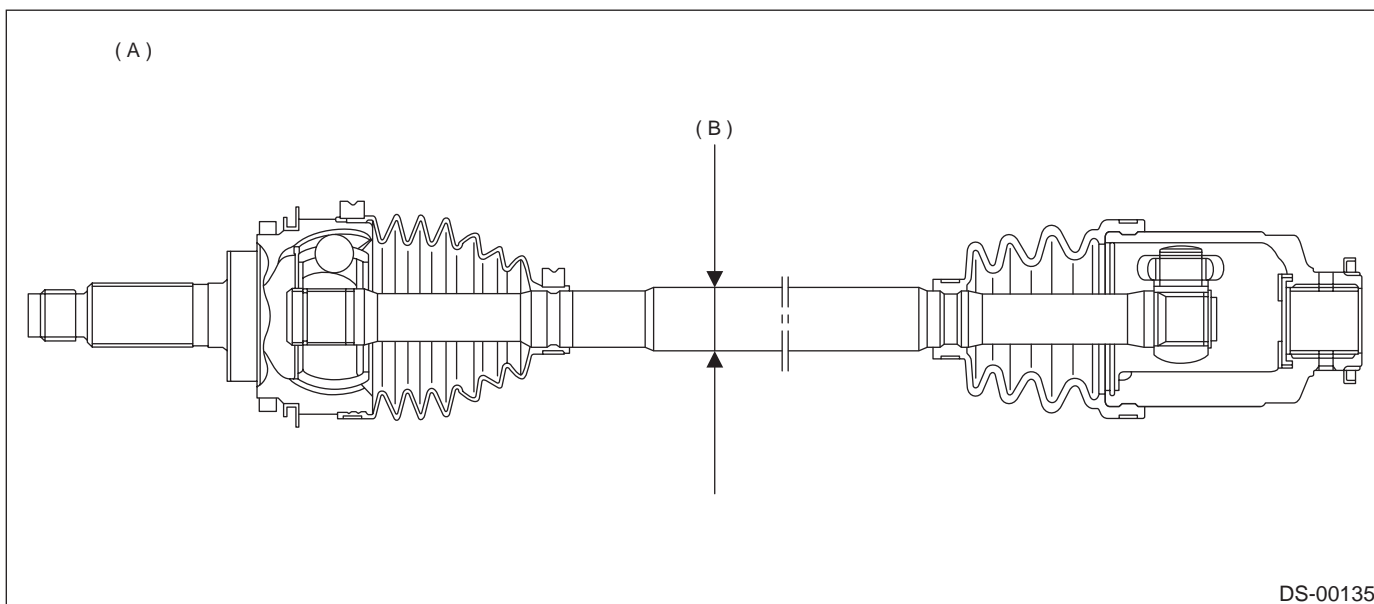

- (A) BJ87+SFJ82
- (B) Measuring point

DS-3

GENERAL DESCRIPTION

DRIVE SHAFT SYSTEM

3. REAR DRIVE SHAFT ASSEMBLY

Type of axle shaft assembly	SHAFT
	No. of identification, protrusion on shaft
82AC-RH, 82AC-LH	2 (Two)
79AC-RH, 79AC-LH	1 (One)
79AC	None

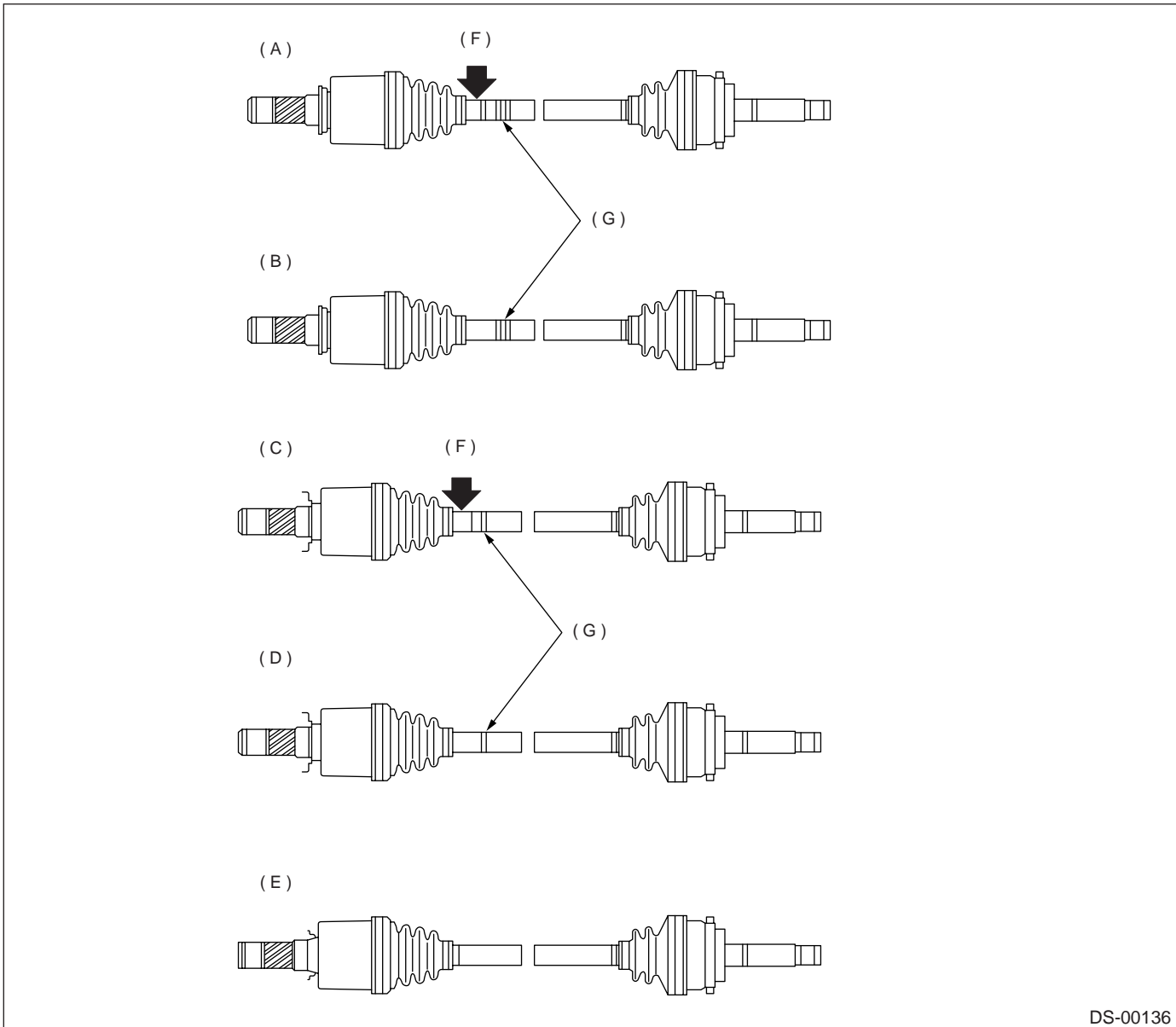

DS-00136

(A) 82AC-RH
 (B) 82AC-LH
 (C) 79AC-RH

(D) 79AC-LH
 (E) 79AC
 (F) Indication mark of RH

(G) Identification protrusion

DS-4

GENERAL DESCRIPTION

DRIVE SHAFT SYSTEM

B: COMPONENT

1. PROPELLER SHAFT

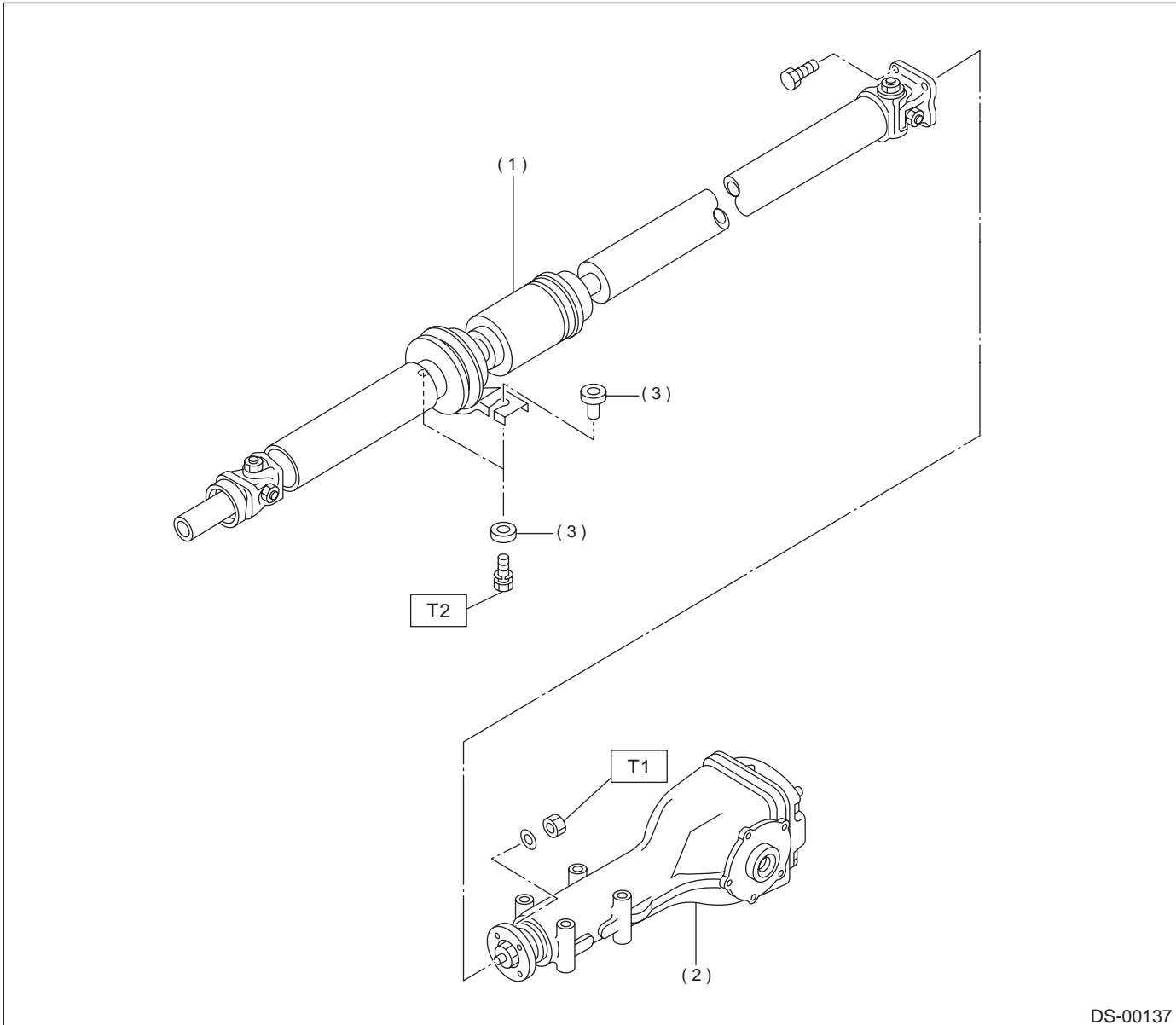

DS-00137

- (1) Propeller shaft
- (2) Rear differential
- (3) Bushing

Tightening torque: N·m (kgf·m, ft·lb)

T1: 31 (3.2, 23.1)

T2: 52 (5.3, 38.3)

DS-5

GENERAL DESCRIPTION

DRIVE SHAFT SYSTEM

2. FRONT AXEL

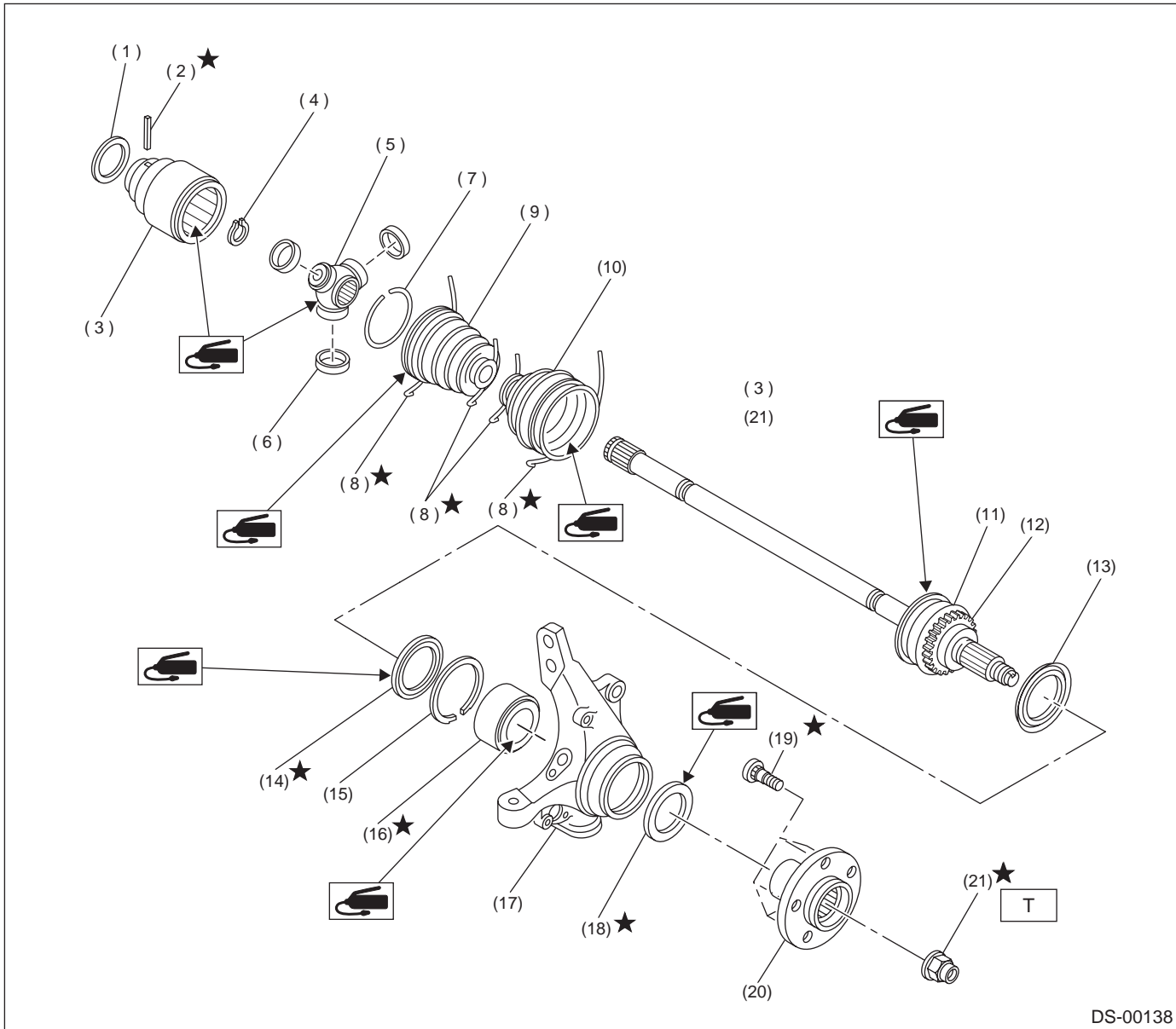

- (1) Baffle plate (SFJ)
- (2) Spring pin
- (3) Outer race (SFJ)
- (4) Snap ring
- (5) Trunnion
- (6) Free ring
- (7) Circlip
- (8) Boot band
- (9) Boot band

- (10) Boot (BJ)
- (11) BJ ASSY
- (12) Tone wheel
- (13) Baffle plate
- (14) Oil seal (IN)
- (15) Snap ring
- (16) Bearing
- (17) Housing
- (18) Oil seal (OUT)

- (19) Hub bolt
- (20) Hub
- (21) Axle nut (Olive color)

Tightening torque: N·m (kgf·m, ft·lb)
T: 216 (22, 159)

DS-6

GENERAL DESCRIPTION

DRIVE SHAFT SYSTEM

3. REAR AXLE

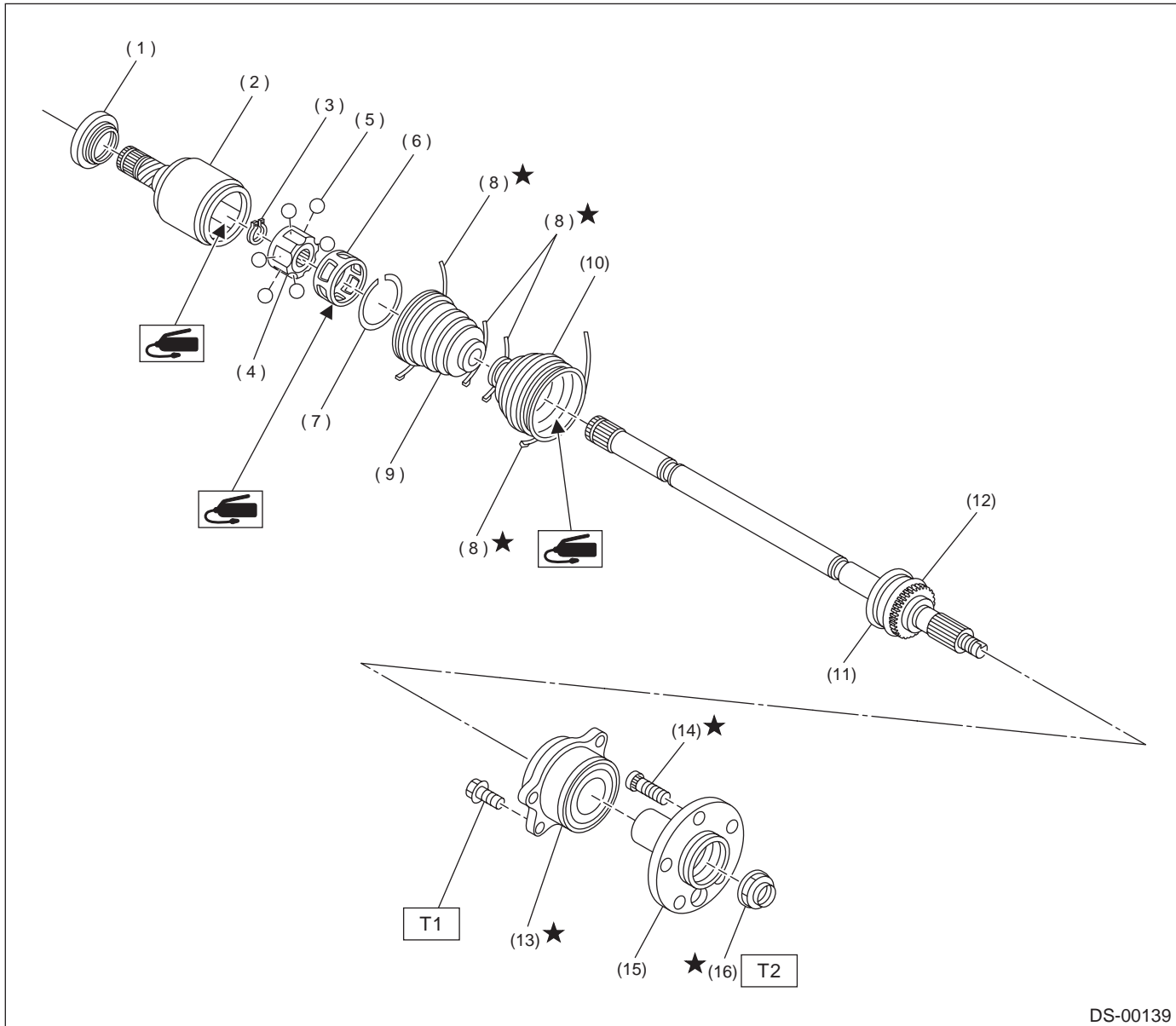

DS-00139

- (1) Baffle plate (DOJ)
- (2) Outer race (DOJ)
- (3) Snap ring
- (4) Inner race
- (5) Ball
- (6) Cage
- (7) Circlip

- (8) Boot band
- (9) Boot (DOJ)
- (10) Boot (BJ)
- (11) BJ ASSY
- (12) Tone wheel
- (13) Hub unit bearing
- (14) Hub bolt

- (15) Hub
- (16) Axle nut (Olive color)

Tightening torque: N·m (kgf·m, ft·lb)

T1: 66 (6.7, 48.5)

T2: 235 (24, 174)

DS-7

GENERAL DESCRIPTION

DRIVE SHAFT SYSTEM

C: CAUTION

- Wear working clothing, including a cap, protective goggles, and protective shoes during operation.
- Remove contamination including dirt and corrosion before removal, installation or disassembly.
- Keep the disassembled parts in order and protect them from dust or dirt.
- Before removal, installation or disassembly, be sure to clarify the failure. Avoid unnecessary removal, installation, disassembly, and replacement.
- Be careful not to burn your hands, because each part on the vehicle is hot after running.
- Use SUBARU genuine grease etc. or the equivalent. Do not mix grease etc. with that of another grade or from other manufacturers.
- Be sure to tighten fasteners including bolts and nuts to the specified torque.
- Place shop jacks or safety stands at the specified points.
- Apply grease onto sliding or revolution surfaces before installation.
- Before installing O-rings or snap rings, apply sufficient amount of grease to avoid damage and deformation.
- Before securing a part on a vise, place cushioning material such as wood blocks, aluminum plate, or shop cloth between the part and the vise.

DS-8

Vehicle-id:
SIE-id::C:CAUTION

GENERAL DESCRIPTION

DRIVE SHAFT SYSTEM

D: MPREPARATION TOOL

1. SPECIAL TOOLS

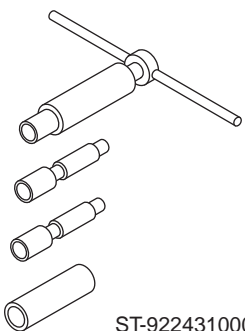
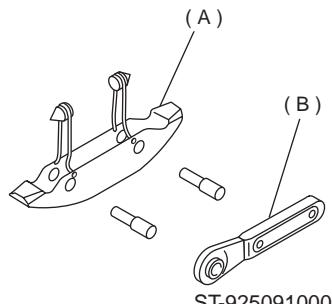
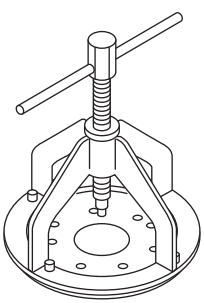
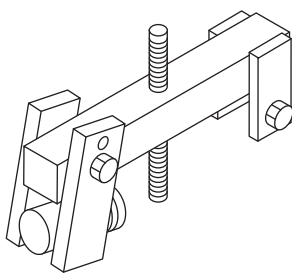
ILLUSTRATION	TOOL NUMBER	DESCRIPTION	REMARKS
 <p>ST-922431000</p>	922431000	AXLE SHAFT INSTALLER	<ul style="list-style-type: none"> Used for installing axle shaft into housing. Used with ADAPTER (927390000).
 <p>ST-925091000</p>	925091000	BAND TIGHTEN- ING TOOL	<ul style="list-style-type: none"> Used for tightening boot band. (A) Jig for band (B) Ratchet wrench
 <p>ST-926470000</p>	926470000	AXLE SHAFT PULLER	Used for removing axle shaft.
 <p>ST-927060000</p>	927060000	HUB REMOVER	<ul style="list-style-type: none"> Used for removing front hub. Used with HUB STAND (927080000).

DS-9

GENERAL DESCRIPTION

DRIVE SHAFT SYSTEM

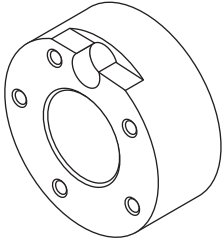
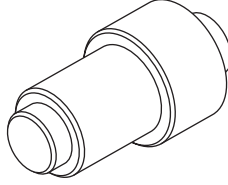
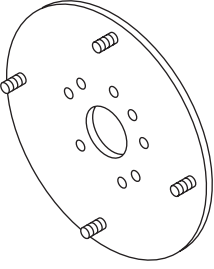
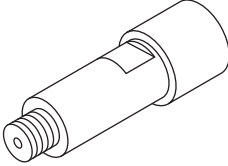
ILLUSTRATION	TOOL NUMBER	DESCRIPTION	REMARKS
 <p style="text-align: center;">ST-927080000</p>	927080000	HUB STAND	Used for disassembling and assembling hub bolt in hub.
 <p style="text-align: center;">ST-927100000</p>	927100000	BEARING PULLER	<ul style="list-style-type: none"> • Used for disassembling and assembling front housing bearing. • Used with HOUSING STAND (927400000).
 <p style="text-align: center;">ST-927140000</p>	927140000	AXLE SHAFT PULLER PLATE	Same as plate 2 included in AXLE SHAFT PULLER (926470000).
 <p style="text-align: center;">ST-927390000</p>	927390000	ADAPTER	Used as an adapter for AXLE SHAFT INSTALLER (922431000).

DS-10

GENERAL DESCRIPTION

DRIVE SHAFT SYSTEM

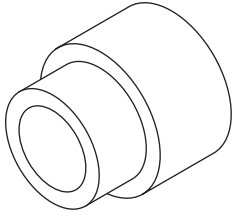
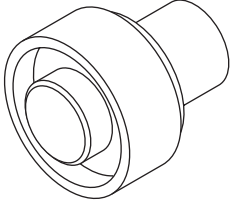
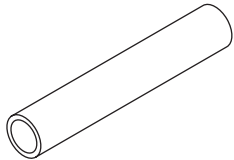
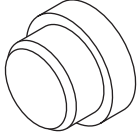
ILLUSTRATION	TOOL NUMBER	DESCRIPTION	REMARKS
 <p>ST-927400000</p>	927400000	HOUSING STAND	<ul style="list-style-type: none"> Used for disassembling and assembling front housing bearing. Used with BEARING PULLER (927100000).
 <p>ST-927410000</p>	927410000	OIL SEAL INSTALLER	<ul style="list-style-type: none"> Used for installing oil seal into front housing. Used with HOUSING STAND (927400000).
 <p>ST-398507703</p>	398507703	DUMMY COLLAR	Used for removing hub ASSY from hub unit.
 <p>ST-399520105</p>	399520105	SEAT	Used for removing inner race from hub ASSY.

DS-11

GENERAL DESCRIPTION

DRIVE SHAFT SYSTEM

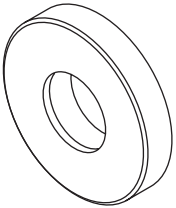
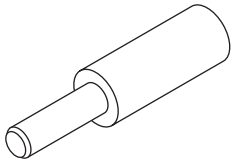
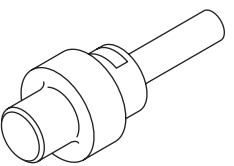
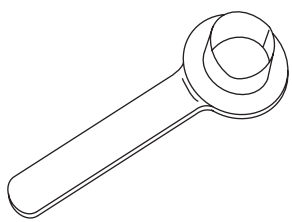
ILLUSTRATION	TOOL NUMBER	DESCRIPTION	REMARKS
 ST28499AE000	28499AE000	BEARING SPACER	Used for installing hub unit into hub ASSY.
 ST-927120000	927120000	HUB INSTALLER	Used for installing hub.
 ST-927450000	927450000	HUB INSTALLER	<ul style="list-style-type: none"> • Used for installing hub unit into hub ASSY. • Used with BEARING SPACER (28499AE000) and HUB STAND (927080000).
 ST28099PA090	28099PA090	OIL SEAL PRO- TECTOR	<ul style="list-style-type: none"> • Used for installing rear drive shaft into rear differential. • For protecting oil seal.

DS-12

GENERAL DESCRIPTION**DRIVE SHAFT SYSTEM**

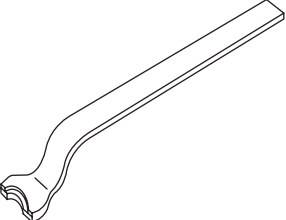
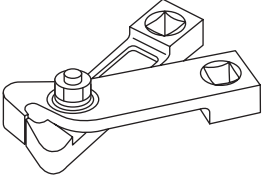
ILLUSTRATION	TOOL NUMBER	DESCRIPTION	REMARKS
 ST28099PA100	28099PA100	DRIVE SHAFT REMOVER	Used for removing rear drive shaft from rear differential.
 ST28099AC000	28099AC000	BOOT BAND PLIERS	Used for tightening front BJ boot band.

2. GENERAL PURPOSE TOOLS

TOOL NAME	REMARKS
Puller	Used for removing ball joint from knuckle arm.
Dial Gauge	Used for inspecting propeller shaft run-out.
Snap Ring Pliers	Used for installing and removing snap ring.

DS-13