

HUB UNIT BEARING

DRIVE SHAFT SYSTEM

4. Hub Unit Bearing

A: REMOVAL

- 1) Disconnect ground cable from battery.
- 2) Jack-up vehicle, and remove rear wheel cap and wheels.

CAUTION:

Be sure to loosen and retighten axle nut after removing wheel from vehicle. Failure to follow this rule may damage wheel bearings.

- 3) Unlock axle nut.
- 4) Remove axle nut using a socket wrench.
- 5) Return parking brake lever.
- 6) Remove ABS sensor.

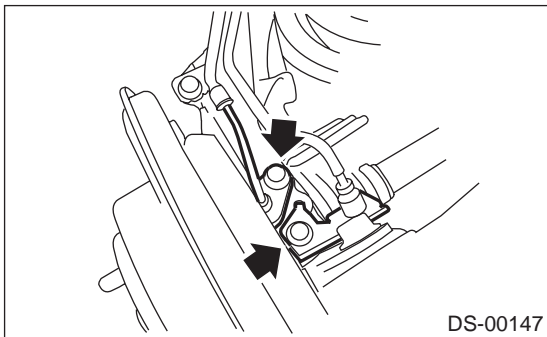

- 7) Remove brake caliper from back plate and suspend it from stabilizer using a piece of wire.

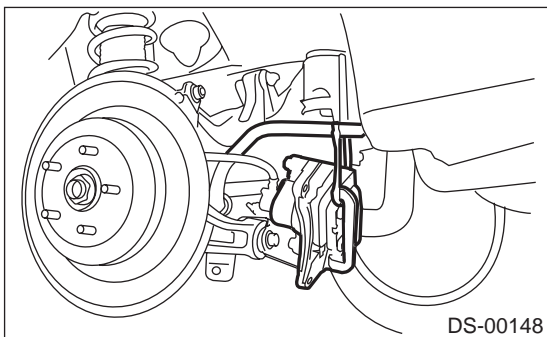

- 8) Remove disc rotor from hub.

NOTE:

- Before removing disc rotor, mark the matching surface of hub and disc rotor so as not to be confused when installing.
- If disc rotor seizes up within hub, drive it out by installing an 8 mm bolt into disc rotor bolt hole.

- 9) Remove four bolts from rear arm.

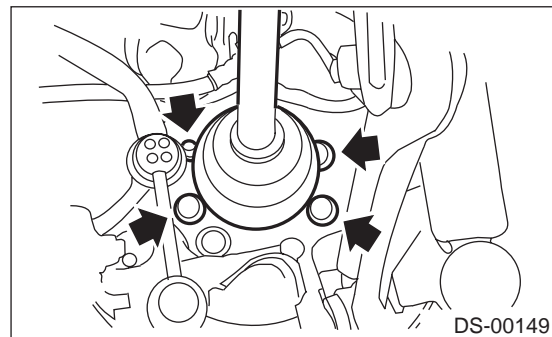

- 10) Remove hub unit bearing.

CAUTION:

Be careful not to damage tone wheel.

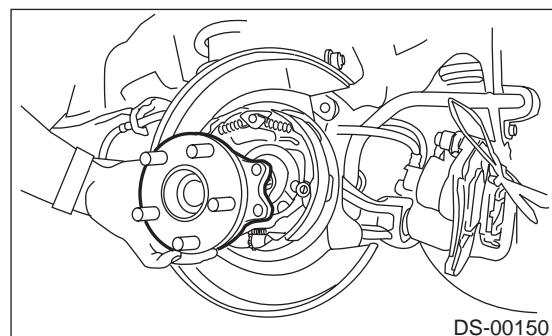

If it is hard to remove, use STs.

- | | | |
|-----|-----------|-------------------|
| ST1 | 926470000 | AXLE SHAFT PULLER |
| ST2 | 927140000 | PLATE |

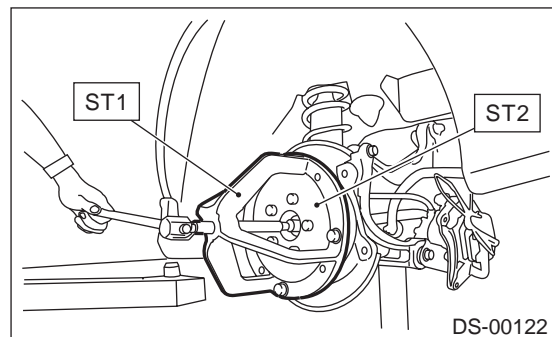

HUB UNIT BEARING

DRIVE SHAFT SYSTEM

B: INSTALLATION

1) Align hub unit bearing with back plate at mounting holes and install hub unit assembly and back plate. Temporarily tighten axle nuts.

CAUTION:

Be careful not to damage tone wheel.

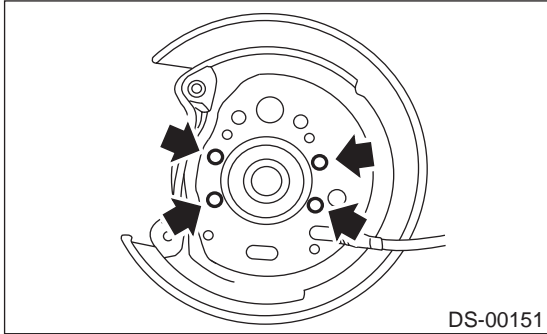

2) Tighten four bolts to back plate.

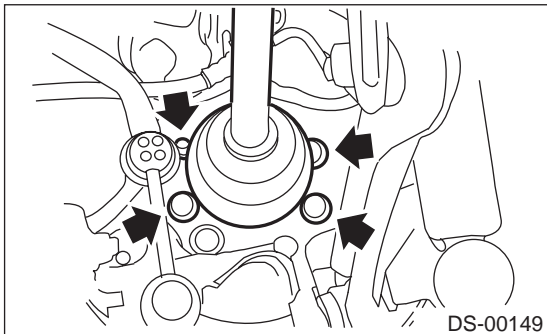

3) Remove axle nut.

4) Using ST1 and ST2, pull axle shaft into place.

ST1 922431000 AXLE SHAFT INSTALLER
ST2 927390000 ADAPTER

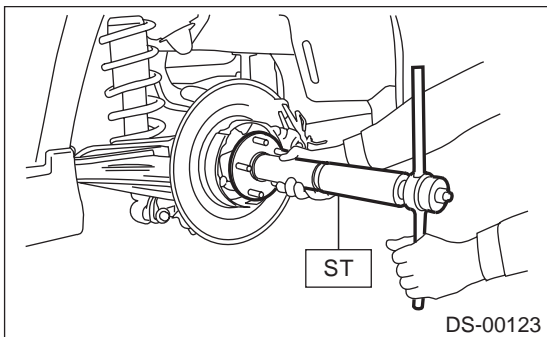

5) Temporarily tighten axle nuts.

6) Install disc rotor on hub.

7) Install disc brake caliper on back plate.

Tightening torque:

52 N·m (5.3 kgf·m, 38.3 ft·lb)

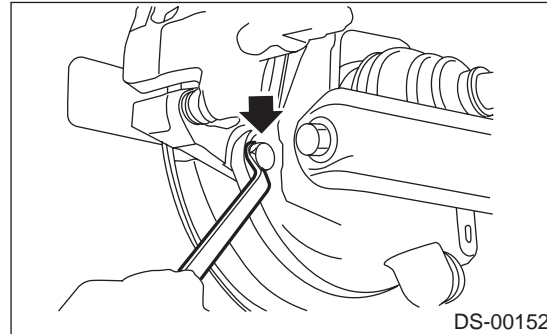

8) Install rear ABS sensor and brake cable bracket.

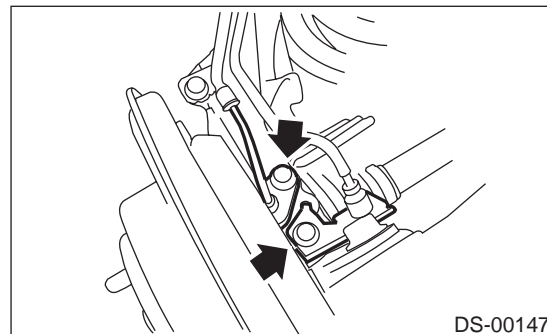

9) Adjust parking brake lever stroke by turning adjuster. <Ref. to PB-5, ADJUSTMENT, Parking Brake Lever.>

HUB UNIT BEARING

DRIVE SHAFT SYSTEM

10) Move brake lever back to apply brakes. While depressing brake pedal, tighten axle nut using a socket wrench. Lock axle nut after tightening.

Tightening torque:

235 N·m (24 kgf·m, 174 ft·lb)

CAUTION:

- Use a new axle nut for rear use only (Olive color).
- Always tighten axle nut before installing wheel on vehicle. If wheel is installed and comes in contact with ground when axle nut is loose, wheel bearings may be damaged.
- Be sure to tighten axle nut to specified torque. Do not overtighten it as this may damage wheel bearing.

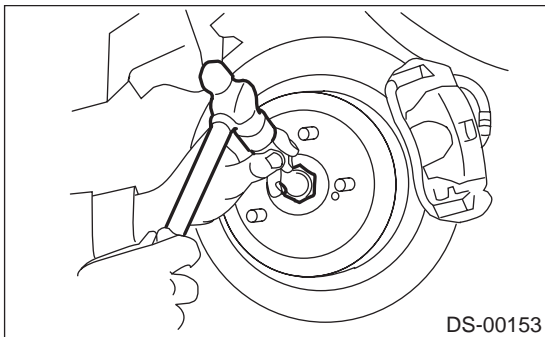

11) Install wheel and tighten wheel nuts to specified torque.

Tightening torque:

88 N·m (9 kgf·m, 65 ft·lb)

C: DISASSEMBLY

1) Using ST, remove hub unit from hub assembly.

CAUTION:

Securely set hub assembly so that it does not lean.

ST 398507703 DUMMY COLLAR

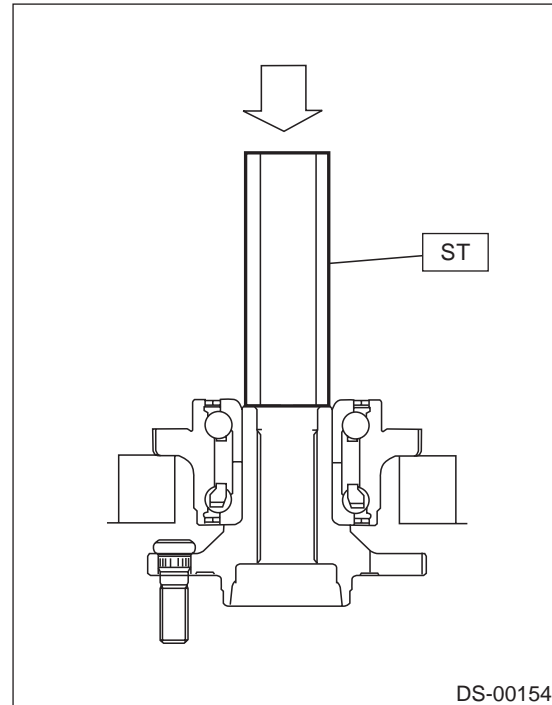

DS-25

HUB UNIT BEARING

DRIVE SHAFT SYSTEM

2) Using ST and a puller (common hand tool), remove bearing inner race.

ST1 399520105 SEAT
ST2 927080000 HUB STAND

CAUTION:

- Do not remove hub unit bearing unless damaged.
- Do not re-use hub unit bearing after removal.

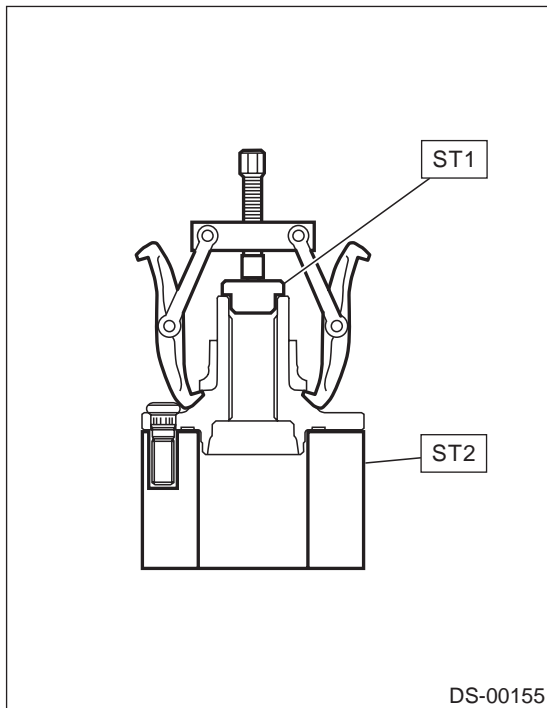

3) Using ST, press hub bolt out.
ST 927080000 HUB STAND

CAUTION:

Be careful not to hammer hub bolts. This may deform hub.

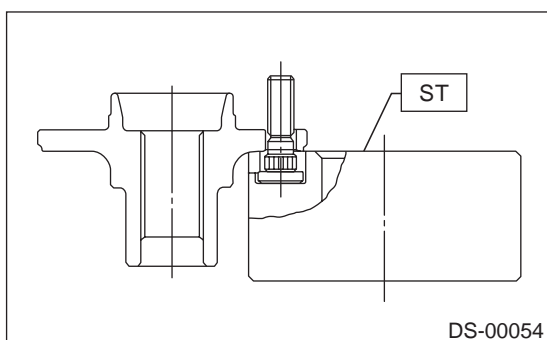

D: ASSEMBLY

1) Using ST, press new hub bolt into place.

CAUTION:

- Ensure hub bolt closely contacts hub.
- Use a 12 mm (0.47 in) hole in the ST to prevent hub bolt from tilting during installation.

ST 927080000 HUB STAND

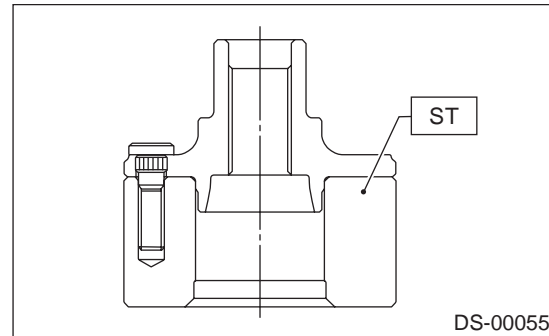

2) Using ST1, ST2 and ST3, press hub unit bearing into hub.

ST1 927080000 HUB STAND
ST2 927450000 HUB INSTALLER
ST3 28499AE000 SPACER

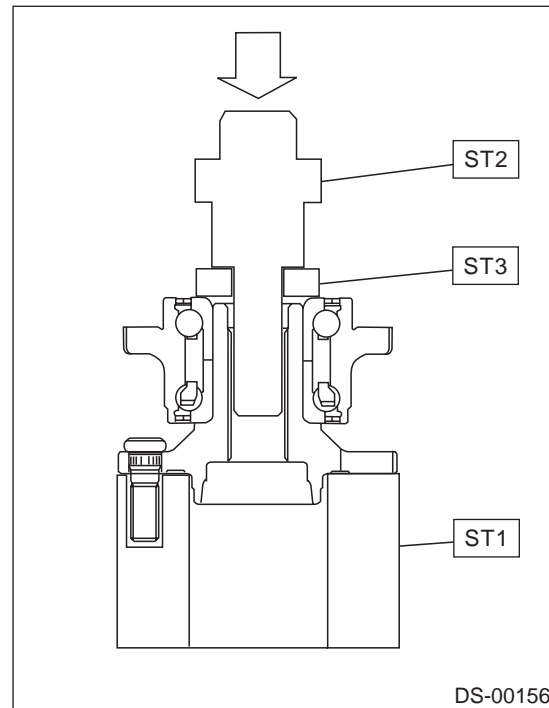

CAUTION:

- Always press inner race when installing hub unit bearing.
- Use a new hub unit bearing.

HUB UNIT BEARING

DRIVE SHAFT SYSTEM

E: INSPECTION

Check the removed parts for wear and damage. If defective, replace with new ones.

CAUTION:

If a bearing is faulty, replace it as a hub unit bearing.

DS-27

Vehicle-id:
SIE-id::E:INSPECTION