

FRONT DRIVE SHAFT

DRIVE SHAFT SYSTEM

5. Front Drive Shaft

A: REMOVAL

- 1) Disconnect ground cable from battery.
- 2) Jack-up vehicle, support it with safety stands (rigid rocks), and remove front wheel cap and wheels.
- 3) Unlock axle nut.
- 4) Depress brake pedal and remove axle nut using a socket wrench.

CAUTION:

Be sure to loosen and retighten axle nut after removing wheel from vehicle. Failure to follow this rule may damage wheel bearings.

- 5) Remove stabilizer link from transverse link.
- 6) Disconnect transverse link from housing.
- 7) Remove spring pin which secures transmission spindle to SFJ.

CAUTION:

Use a new spring pin.

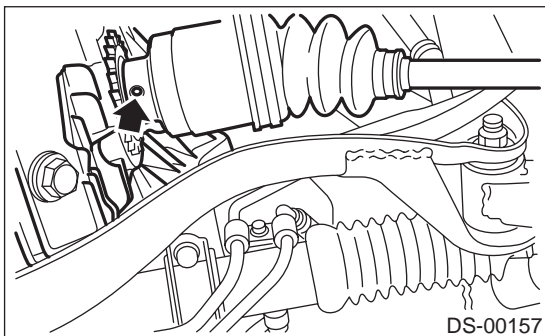

- 8) Remove front drive shaft assembly. If it is hard to remove, use ST1 and ST2.

ST1 926470000 AXLE SHAFT PULLER
ST2 927140000 PLATE

CAUTION:

- **Be careful not to damage oil seal lip and tone wheel when removing front drive shaft.**
- **When front drive shaft is to be replaced, also replace inner oil seal.**

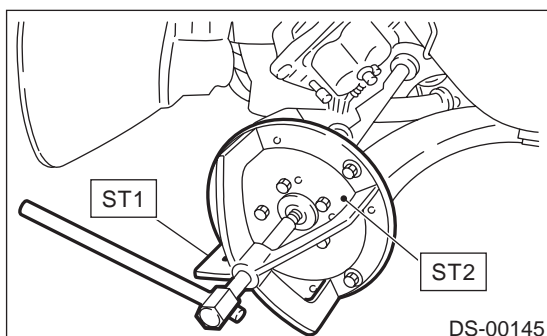

B: INSTALLATION

- 1) Insert BJ into hub splines.

CAUTION:

Be careful not to damage inner oil seal lip and tone wheel.

- 2) Using ST1 and ST2, pull drive shaft into place.
ST1 922431000 AXLE SHAFT INSTALLER
ST2 927390000 ADAPTER

CAUTION:

Do not hammer drive shaft when installing it.

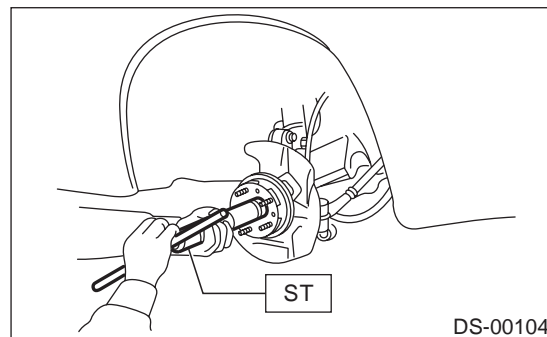

- 3) Tighten axle nut temporarily.
- 4) Install SFJ on transmission spindle and drive spring pin into place.

CAUTION:

Always use a new spring pin.

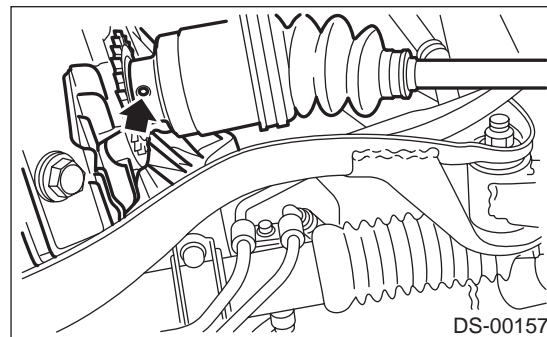

- 5) Connect transverse link to housing.

Tightening torque (self-locking nut):
49 N·m (5.0 kgf-m, 36 ft-lb)

CAUTION:

Use a new self-locking nut.

- 6) Install stabilizer bracket.

FRONT DRIVE SHAFT

DRIVE SHAFT SYSTEM

7) While depressing brake pedal, tighten axle nut to the specified torque.

Tightening torque:

216 N·m (22 kgf·m, 159 ft·lb)

CAUTION:

- Use a new axle nut (3.0 L model: Olive color, 2.5 L model: Gold color).
- Always tighten axle nut before installing wheel on vehicle. If wheel is installed and comes in contact with ground when axle nut is loose, wheel bearings may be damaged.
- Be sure to tighten axle nut to specified torque. Do not overtighten it as this may damage wheel bearing.

8) After tightening axle nut, lock it securely.

C: DISASSEMBLY

1) Place alignment marks on shaft and outer race.

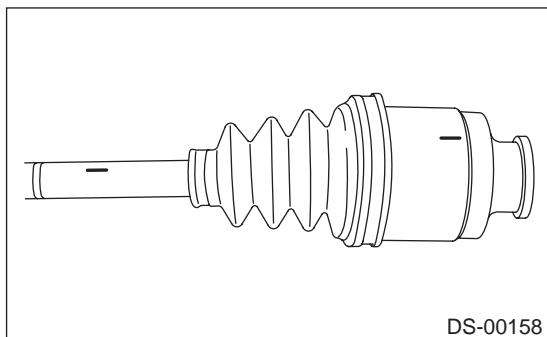

2) Remove SFJ boot band and boot.

CAUTION:

Be careful not to damage boot.

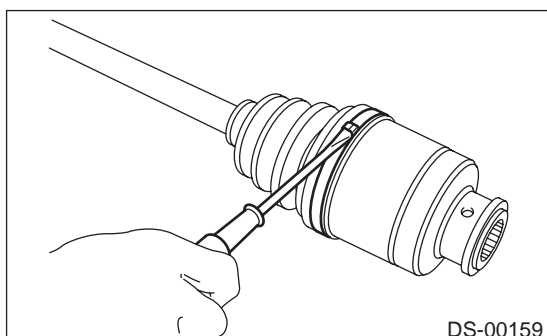

3) Remove circlip from SFJ outer race using screwdriver.

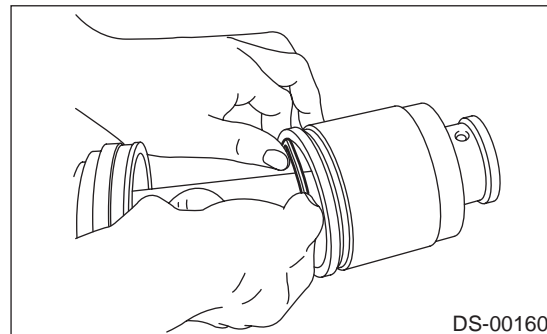

4) Remove SFJ outer race from shaft assembly.
5) Wipe off grease.

CAUTION:

The grease is a special grease. Do not confuse with other greases.

6) Place alignment mark on free ring and trunnion.

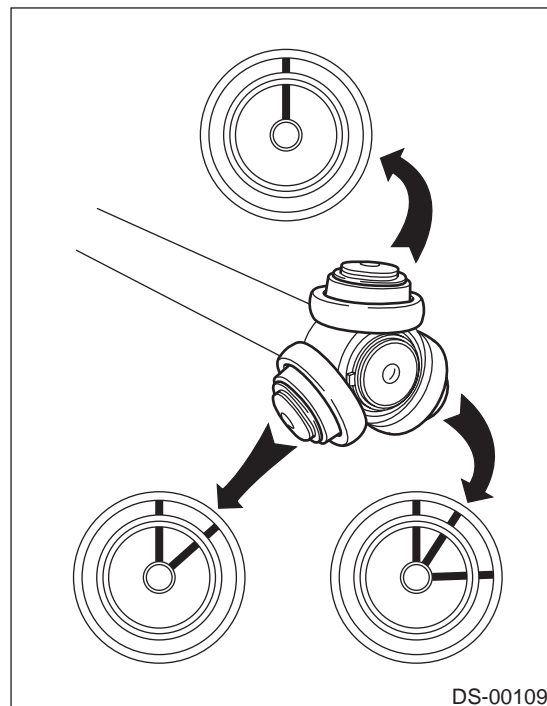

7) Remove free ring from trunnion.

CAUTION:

Be careful with the free ring position.

DS-29

FRONT DRIVE SHAFT

DRIVE SHAFT SYSTEM

8) Place alignment mark on trunnion and shaft.

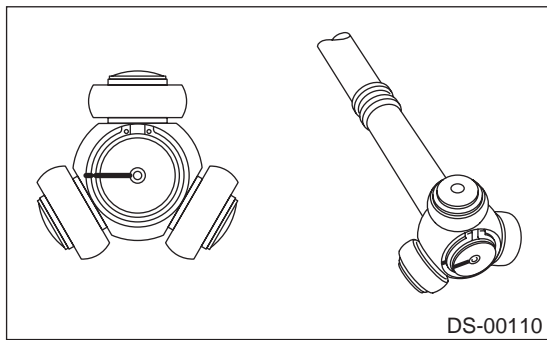

9) Remove snap ring and trunnion.

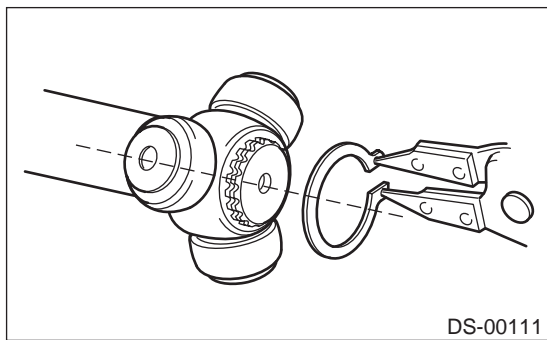

CAUTION:

Be sure to wrap shaft splines with vinyl tape to prevent boot from scratches.

10) Remove SFJ boot.

11) Place drive shaft in a vise between wooden blocks.

CAUTION:

Do not place drive shaft directly in the vise; use wooden block.

12) Raise boot band claws by means of screwdriver and hammer.

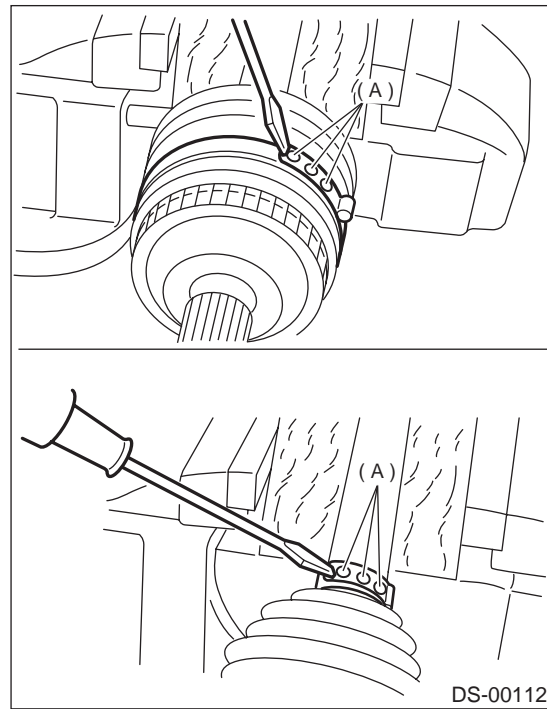

(A) Boot band claws

13) Cut and remove the boot.

CAUTION:

The boot must be replaced with a new one whenever it is removed.

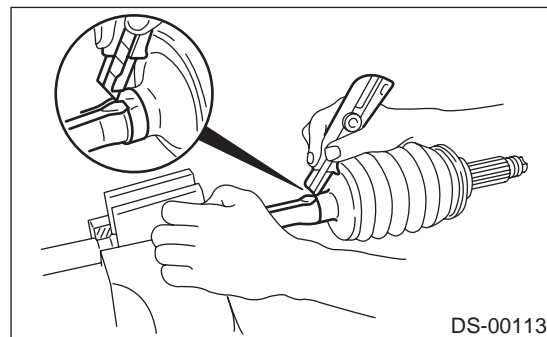

14) Thus, disassembly of axle is completed, but BJ cannot be disassembled.

FRONT DRIVE SHAFT

DRIVE SHAFT SYSTEM

D: ASSEMBLY

CAUTION:
Use specified grease.

BJ side:

NTG2218 (Part No. 28093AA000)

SFJ side:

SSG6003 (Part No. 28093TA000)

1) Place BJ boot and small boot band on BJ side of shaft.

CAUTION:

Be sure to wrap shaft splines with vinyl tape to prevent boot from scratches.

2) Place drive shaft in a vise.

CAUTION:

Do not place drive shaft directly in the vise; use wooden blocks.

3) Apply a coat of specified grease [60 to 70 g (2.12 to 2.47 oz)] to BJ.

4) Apply an even coat of specified grease [20 to 30 g (0.71 to 1.06 oz)] to the entire inner surface of boot. Also apply grease to shaft.

NOTE:

The inside of the larger end of BJ boot and the boot groove shall be cleaned so as to be free from grease and other substances.

5) Install boot projecting portion to BJ groove.

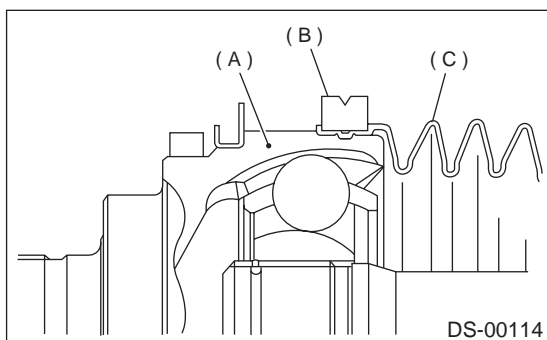

- (A) BJ
- (B) Large boot band
- (C) Boot

6) Set large boot band in place.

7) Install boot projecting portion to shaft groove.

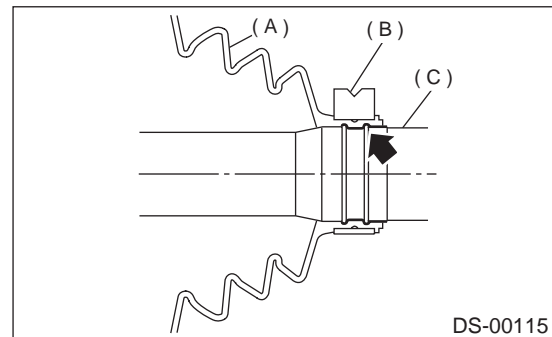

- (A) Boot
- (B) Small boot band
- (C) Shaft

8) Tighten boot bands using ST, torque wrench and socket flex handle.

ST 28099AC000 BOOT BAND PLIER

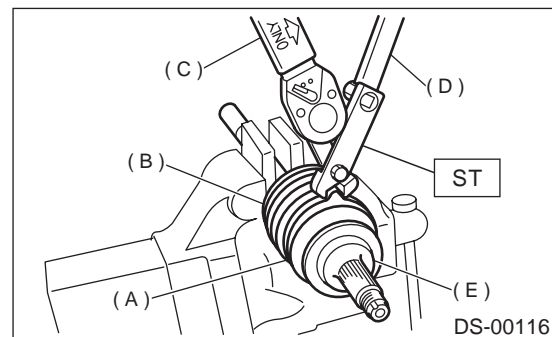

- (A) Large boot band
- (B) Boot
- (C) Torque wrench
- (D) Socket flex handle
- (E) BJ

Tightening torque:

Large boot band

157 N·m (16.0 kgf·m, 116 ft·lb) or more

Small boot band

133 N·m (13.6 kgf·m, 98 ft·lb) or more

9) Place SFJ boot at the center of shaft.

10) Align alignment marks and install trunnion on shaft.

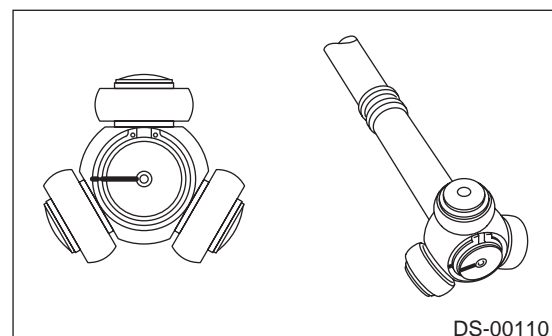

DS-31

FRONT DRIVE SHAFT

DRIVE SHAFT SYSTEM

11) Install snap ring to shaft.

CAUTION:

Confirm that the snap ring is completely fitted in the shaft groove.

12) Fill 100 to 110 g (3.53 to 3.88 oz) of specified grease into the interior of SFJ outer race.

13) Apply a coat of specified grease to free ring and trunnion.

14) Align alignment marks on free ring and trunnion and install free ring.

CAUTION:

Be careful with the free ring position.

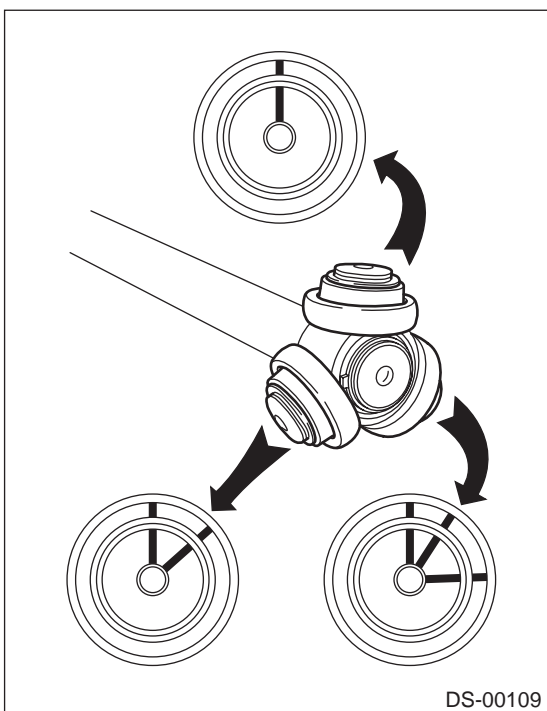

15) Align alignment marks on shaft and outer race, and install outer race.

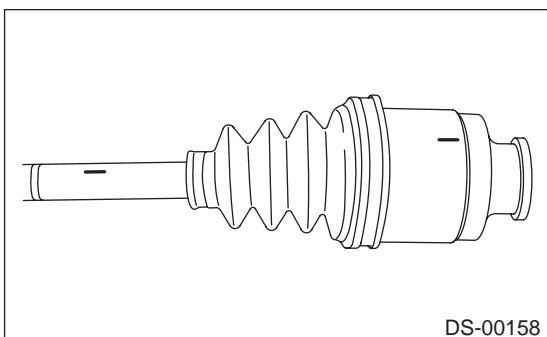

16) Install circlip in the groove on SFJ outer race.

CAUTION:

Pull the shaft lightly and assure that the circlip is completely fitted in the groove.

17) Apply an even coat of the specified grease 30 to 40 g (1.06 to 1.41 oz) to the entire inner surface of boot.

18) Install SFJ boot taking care not to twist it.

CAUTION:

• **The inside of the larger end of SFJ boot and the boot groove shall be cleaned so as to be free from grease and other substances.**

• **When installing SFJ boot, position outer race of SFJ at center of its travel.**

19) Put a band through the clip and wind twice in alignment with band groove of boot.

CAUTION:

Use a new band.

20) Pinch the end of band with pliers. Hold the clip and tighten securely.

NOTE:

When tightening boot, exercise care so that the air within the boot is appropriate.

21) Tighten band by using ST.

ST 925091000 BAND TIGHTENING TOOL

NOTE:

Tighten band until it cannot be moved by hand.

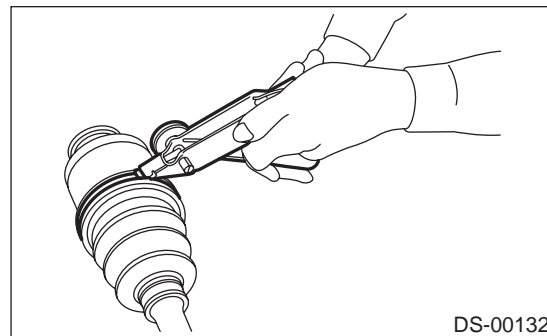

22) Tap on the clip with the punch provided at the end of ST.

ST 925091000 BAND TIGHTENING TOOL

CAUTION:

Tap to an extent that the boot underneath is not damaged.

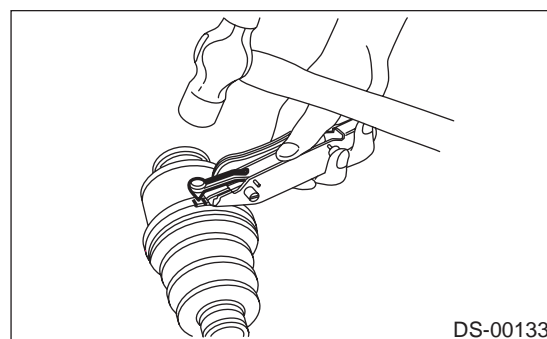

DS-32

FRONT DRIVE SHAFT

DRIVE SHAFT SYSTEM

23) Cut off band with an allowance of about 10 mm (0.39 in) left from the clip and bend this allowance over the clip.

CAUTION:

Be careful so that the end of the band is in close contact with clip.

24) Fix up boot on BJ in the same manner.

NOTE:

Extend and retract SFJ to provide equal grease coating.

E: INSPECTION

Check the removed parts for damage, wear, corrosion etc. If faulty, repair or replace.

1) DOJ (Double Offset Joint)

Check seizure, corrosion, damage, wear and excessive play.

2) SFJ (Shudder-less Free-ring tripod Joint)

Check seizure, corrosion, damage and excessive play.

3) Shaft

Check excessive bending, twisting, damage and wear.

4) BJ (Bell Joint)

Check seizure, corrosion, damage and excessive play.

5) Boot

Check for wear, warping, breakage or scratches.

6) Grease

Check for discoloration or fluidity.

DS-33