

## REAR DRIVE SHAFT

### DRIVE SHAFT SYSTEM

## 6. Rear Drive Shaft

### A: REMOVAL

- 1) Disconnect ground cable from battery.
- 2) Lift-up vehicle, and remove rear wheel cap and wheels.

#### CAUTION:

**Be sure to loosen and retighten axle nut after removing wheel from vehicle. Failure to follow this rule may damage wheel bearings.**

- 3) Unlock axle nut.
  - 4) Remove axle nut using a socket wrench.
  - 5) Remove rear differential assembly.
- With T-type  
<Ref. to DI-24, REMOVAL, Rear Differential for T-type.>
- With VA-type  
<Ref. to DI-41, REMOVAL, Rear Differential for VA-type.>
- 6) Remove axle nut and drive shaft. If it is hard to remove, use ST1 and ST2.

ST1 926470000 AXLE SHAFT PULLER  
ST2 927140000 PLATE

#### CAUTION:

**Be careful not to damage tone wheel when removing rear drive shaft.**

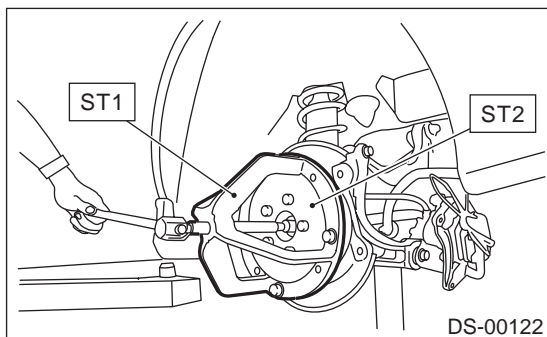

### B: INSTALLATION

- 1) Insert BJ into rear hub splines.

#### CAUTION:

**Be careful not to damage tone wheel.**

- 2) Using ST1 and ST2, pull drive shaft into place.  
ST1 922431000 AXLE SHAFT INSTALLER  
ST2 927390000 ADAPTER

#### CAUTION:

**Do not hammer drive shaft when installing it.**

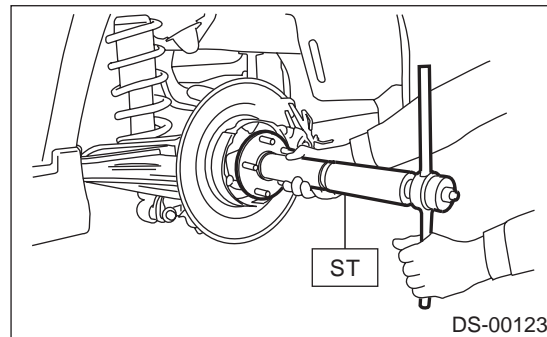

- 3) Tighten axle nut temporarily.
- 4) Install rear differential.  
With T-type  
<Ref. to DI-25, INSTALLATION, Rear Differential for T-type.>  
With VA-type  
<Ref. to DI-42, INSTALLATION, Rear Differential for VA-type.>
- 5) While depressing brake pedal, tighten axle nut using a socket wrench.

#### Tightening torque:

**235 N·m (24 kgf·m, 174 ft·lb)**

#### CAUTION:

- Use a new axle nut for rear use only (Olive color).
- Always tighten axle nut before installing wheel on vehicle. If wheel is installed and comes in contact with ground when axle nut is loose, wheel bearings may be damaged.
- Be sure to tighten axle nut to specified torque. Do not overtighten it as this may damage wheel bearing.

- 6) After tightening axle nut, lock it securely.

## REAR DRIVE SHAFT

DRIVE SHAFT SYSTEM

### C: DISASSEMBLY

- 1) Straighten bent claw of larger end of DOJ boot.
- 2) Loosen band by means of screwdriver or pliers, being careful not to damage the boot.

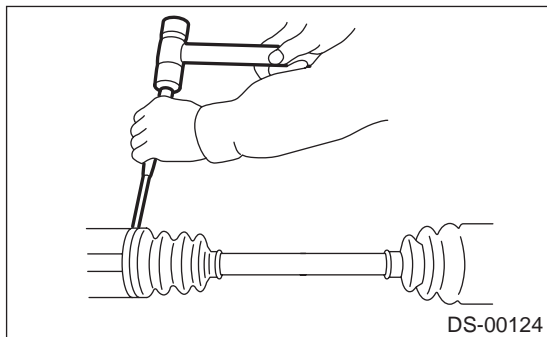

- 3) Remove boot band on the small end of DOJ boot in the same manner.
- 4) Remove the larger end of DOJ boot from DOJ outer race.
- 5) Pry and remove round circlip located at the neck of DOJ outer race with a screwdriver.

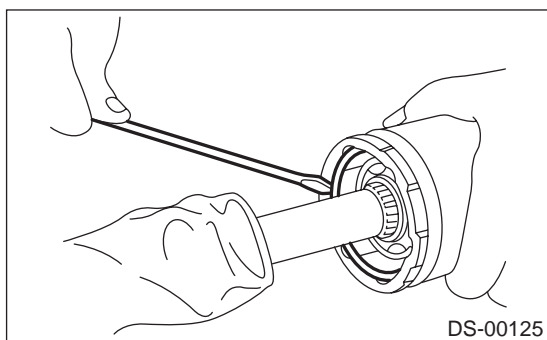

- 6) Take out DOJ outer race from shaft assembly.

- 7) Wipe off grease and take out balls.

#### CAUTION:

The grease is a special grease (grease for constant velocity joint). Do not confuse with other greases.

#### NOTE:

Disassemble exercising care not to lose balls (6 pcs).

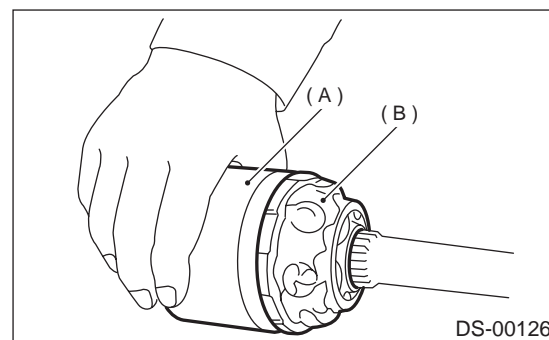

- (A) Outer race  
(B) Grease

- 8) To remove the cage from the inner race, turn the cage by a half pitch to the track groove of the inner race and shift the cage.
- 9) Remove snap ring, which fixes inner race to shaft, by using pliers.
- 10) Take out DOJ inner race.
- 11) Take off DOJ cage from shaft and remove DOJ boot.

#### CAUTION:

Be sure to wrap shaft splines with vinyl tape to prevent boot from scratches.

- 12) Remove BJ boot in the same procedure as DOJ boot.
- 13) Thus, disassembly of axle is completed, but BJ is unable to be disassembled.

DS-35

## REAR DRIVE SHAFT

### DRIVE SHAFT SYSTEM

#### D: ASSEMBLY

**CAUTION:**

Use specified grease.

**BJ side:**

**Molylex No. 2 (Part No. 723223010)**

**DOJ side:**

**VU-3A702 (Yellow) (Part No. 23223GA050)**

- 1) Install BJ boot in specified position, and fill it with 60 to 70 g (2.12 to 2.47 oz) of specified grease.
- 2) Place DOJ boot at the center of shaft.

**CAUTION:**

Be sure to wrap shaft splines with vinyl tape to prevent boot from scratches.

- 3) Insert DOJ cage onto shaft.

**NOTE:**

Insert the cage with the cut-out portion facing the shaft end, since the cage has an orientation.

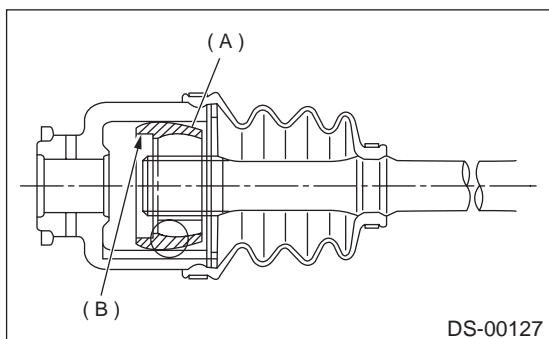

- (A) Cage
- (B) Cut-out portion

- 4) Install DOJ inner race on shaft and fit snap ring with pliers.

**NOTE:**

Confirm that the snap ring is completely fitted in the shaft groove.

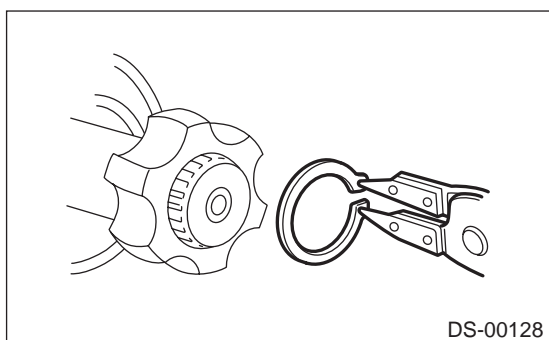

DS-00128

- 5) Install cage, which was previously fitted, to inner race fixed upon shaft.

**NOTE:**

Fit the cage with the protruded part aligned with the track on the inner race and then turn by a half pitch.

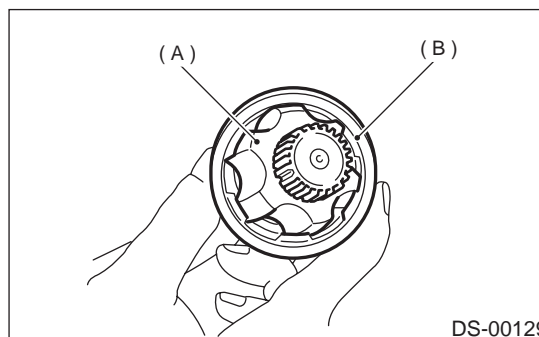

- (A) Inner race
- (B) Cage

- 6) Fill 80 to 90 g (2.82 to 3.17 oz) of specified grease into the interior of DOJ outer race.
- 7) Apply a coat of specified grease to the cage pocket and six balls.
- 8) Insert six balls into the cage pocket.
- 9) Align the outer race track and ball positions and place in the part where shaft, inner race, cage and balls are previously installed, and then fit outer race.

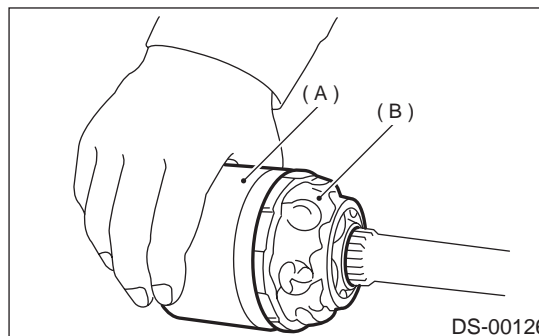

- (A) Outer race
- (B) Grease

DS-36

## REAR DRIVE SHAFT

DRIVE SHAFT SYSTEM

10) Install circlip in the groove on DOJ outer race.

**NOTE:**

- Assure that the balls, cage and inner race are completely fitted in the outer race of DOJ.
- Exercise care not to place the matched position of circlip in the ball groove of outer race.
- Pull the shaft lightly and assure that the circlip is completely fitted in the groove.

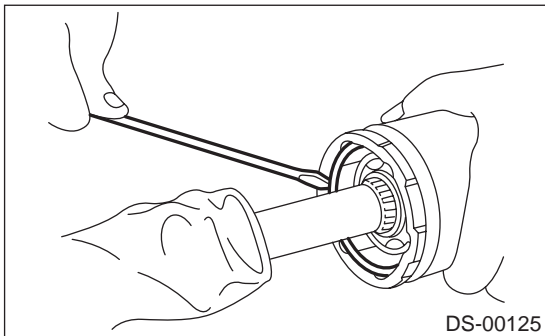

11) Apply an even coat of the specified grease [20 to 30 g (0.71 to 1.06 oz)] to the entire inner surface of boot. Also apply grease to shaft.

12) Install DOJ boot taking care not to twist it.

**NOTE:**

- The inside of the larger end of DOJ boot and the boot groove shall be cleaned so as to be free from grease and other substances.
- When installing DOJ boot, position outer race of DOJ at center of its travel.

13) Put a band through the clip and wind twice in alignment with band groove of boot.

**CAUTION:**  
**Use a new band.**

14) Pinch the end of band with pliers. Hold the clip and tighten securely.

**NOTE:**

When tightening boot, exercise care so that the air within the boot is appropriate.

15) Tighten band by using ST.

ST 925091000 BAND TIGHTENING TOOL

**NOTE:**

Tighten band until it cannot be moved by hand.

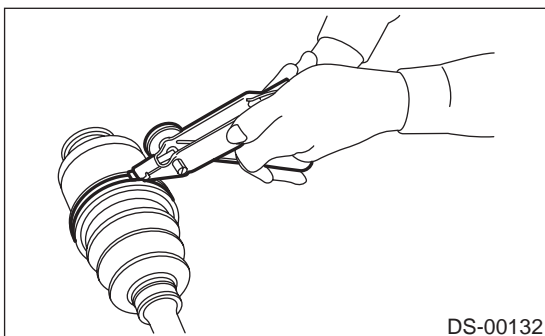

16) Tap on the clip with the punch provided at the end of ST.

ST 925091000 BAND TIGHTENING TOOL

**CAUTION:**

**Tap to an extent that the boot underneath is not damaged.**

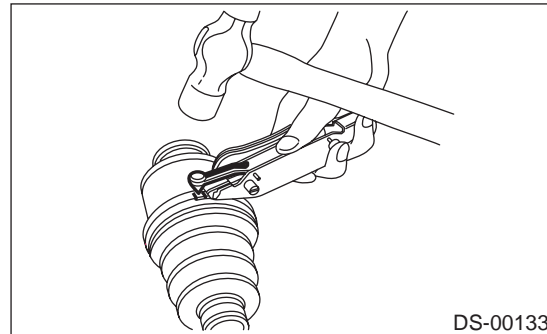

17) Cut off band with an allowance of about 10 mm (0.39 in) left from the clip and bend this allowance over the clip.

**CAUTION:**

**Be careful so that the end of the band is in close contact with clip.**

18) Fix up boot on BJ in the same manner.

**NOTE:**

Extend and retract DOJ to provide equal grease coating.

### E: INSPECTION

Check the removed parts for damage, wear, corrosion etc. If faulty, repair or replace.

1) DOJ (Double Offset Joint)

Check seizure, corrosion, damage, wear and excessive play.

2) SFJ (Shudder-less Free-ring tripod Joint)

Check seizure, corrosion, damage and excessive play.

3) Shaft

Check excessive bending, twisting, damage and wear.

4) BJ (Bell Joint)

Check seizure, corrosion, damage and excessive play.

5) Boot

Check for wear, warping, breakage or scratches.

6) Grease

Check for discoloration or fluidity.

### DS-37