

GENERAL DESCRIPTION

REAR SUSPENSION

1. General Description

A: SPECIFICATIONS

Item	Sedan	Wagon	OUTBACK
Camber (tolerance: $\pm 0^{\circ}45'$)	$-0^{\circ}30'$	$-0^{\circ}20'$	$-0^{\circ}10'$
Toe-in	0 \pm 3 mm (0 \pm 0.12 in) Each toe-in angle: $\pm 0^{\circ}15'$		
Wheel arch height [tolerance: $+12/-24$ mm ($+0.47/-0.94$ in)]	371 mm (14.61 in)	381 mm (15.00 in)	421 mm (16.57 in)
Thrust angle	0 \pm 30'		
Diameter of stabilizer	16 mm (0.63 in)		

NOTE:

- Front and rear toe-in and front camber can be adjusted. If toe-in or camber tolerance exceeds specifications, adjust toe-in and camber to the middle value of specification.
- The other items indicated in the specification table cannot be adjusted. If the other items exceed specifications, check suspension parts and connections for deformities; replace with new ones as required.

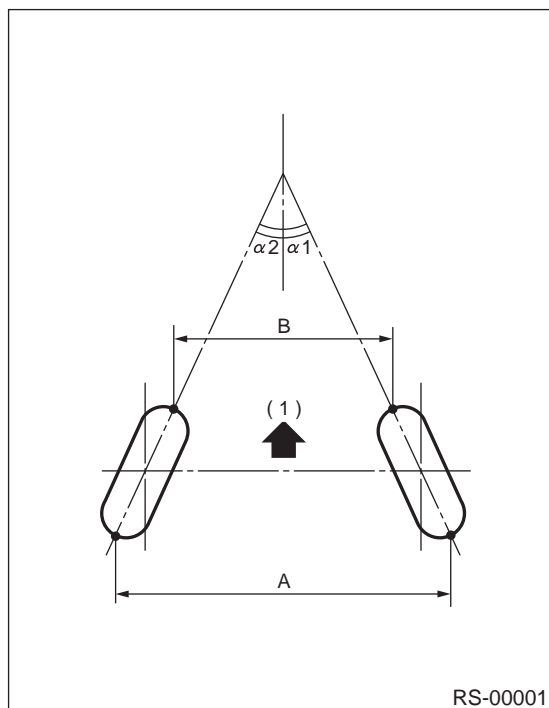

(1) Front

A - B = Positive: Toe-in, Negative: Toe-out

$\alpha 1, \alpha 2$: Each toe-in angle

RS-2

GENERAL DESCRIPTION

REAR SUSPENSION

B: COMPONENT

1. REAR SUSPENSION

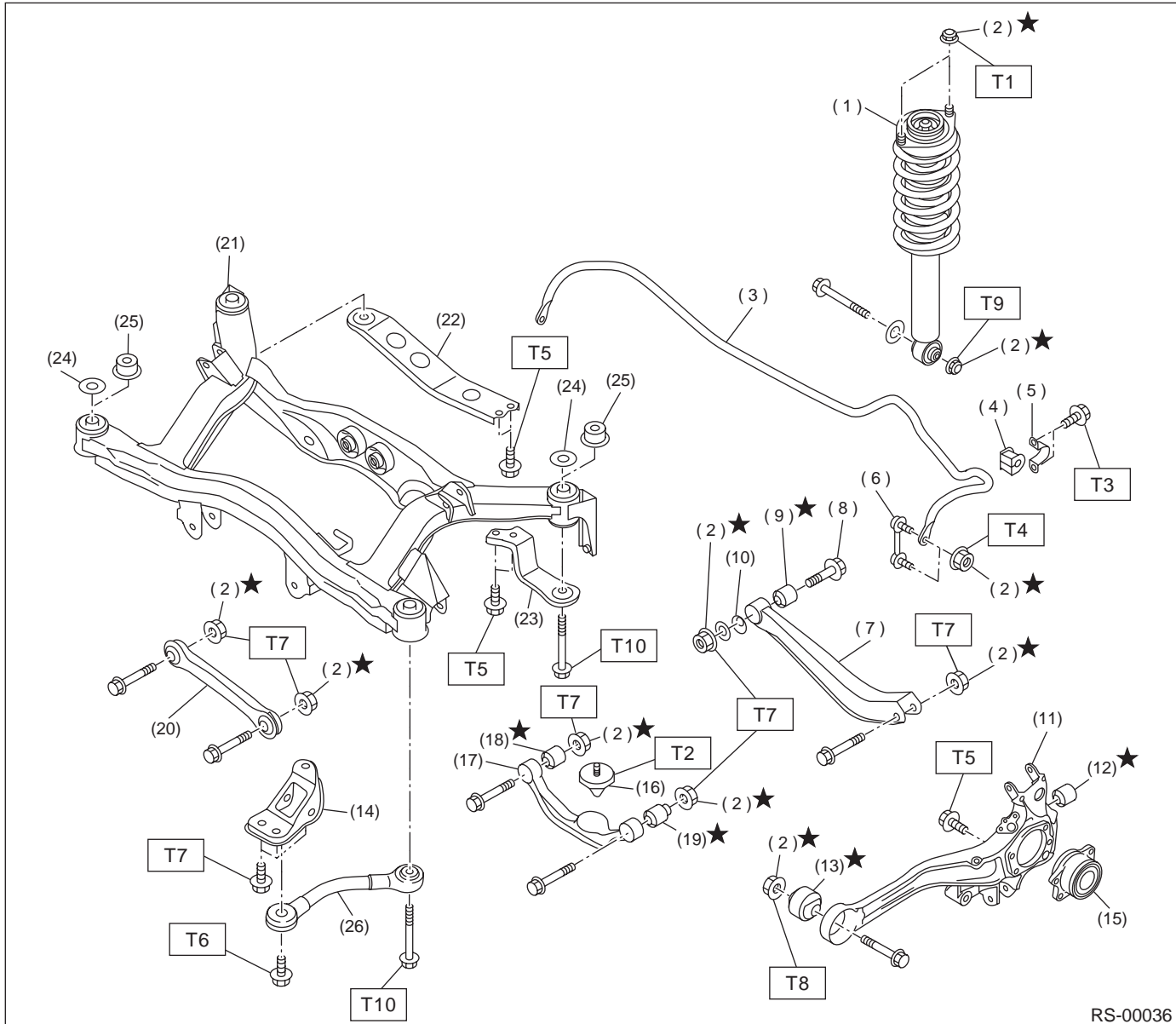

RS-00036

- | | |
|-----------------------------|---|
| (1) Shock absorber | (15) Hub bearing unit |
| (2) Self-locking nut | (16) Helper |
| (3) Stabilizer | (17) Link upper |
| (4) Stabilizer bushing | (18) Link upper bushing (Inside) |
| (5) Clamp | (19) Link upper bushing (Outside) |
| (6) Stabilizer link | (20) Link front |
| (7) Link rear | (21) Rear sub frame |
| (8) Adjusting bolt | (22) Support sub frame (RH) |
| (9) Link rear bushing | (23) Support sub frame (LH) |
| (10) Adjusting washer | (24) Stopper upper (Except OUTBACK model) |
| (11) Rear arm | (25) Stopper upper (OUTBACK MODEL) |
| (12) Rear arm rear bushing | (26) Support sub frame front |
| (13) Rear arm front bushing | |
| (14) Rear arm bracket | |

Tightening torque: N·m (kgf·m, ft·lb)

- | | |
|-------------|------------------------|
| T1: | 30 (3.1, 22.4) |
| T2: | 32 (3.3, 24) |
| T3: | 40 (4.1, 30) |
| T4: | 44 (4.5, 32.5) |
| T5: | 65 (6.6, 48) |
| T6: | 80 (8.2, 59) |
| T7: | 120 (12.2, 88) |
| T8: | 150 (15.3, 111) |
| T9: | 160 (16.3, 118) |
| T10: | 175 (17.8, 129) |

RS-3

GENERAL DESCRIPTION

REAR SUSPENSION

2. SHOCK ABSORBER

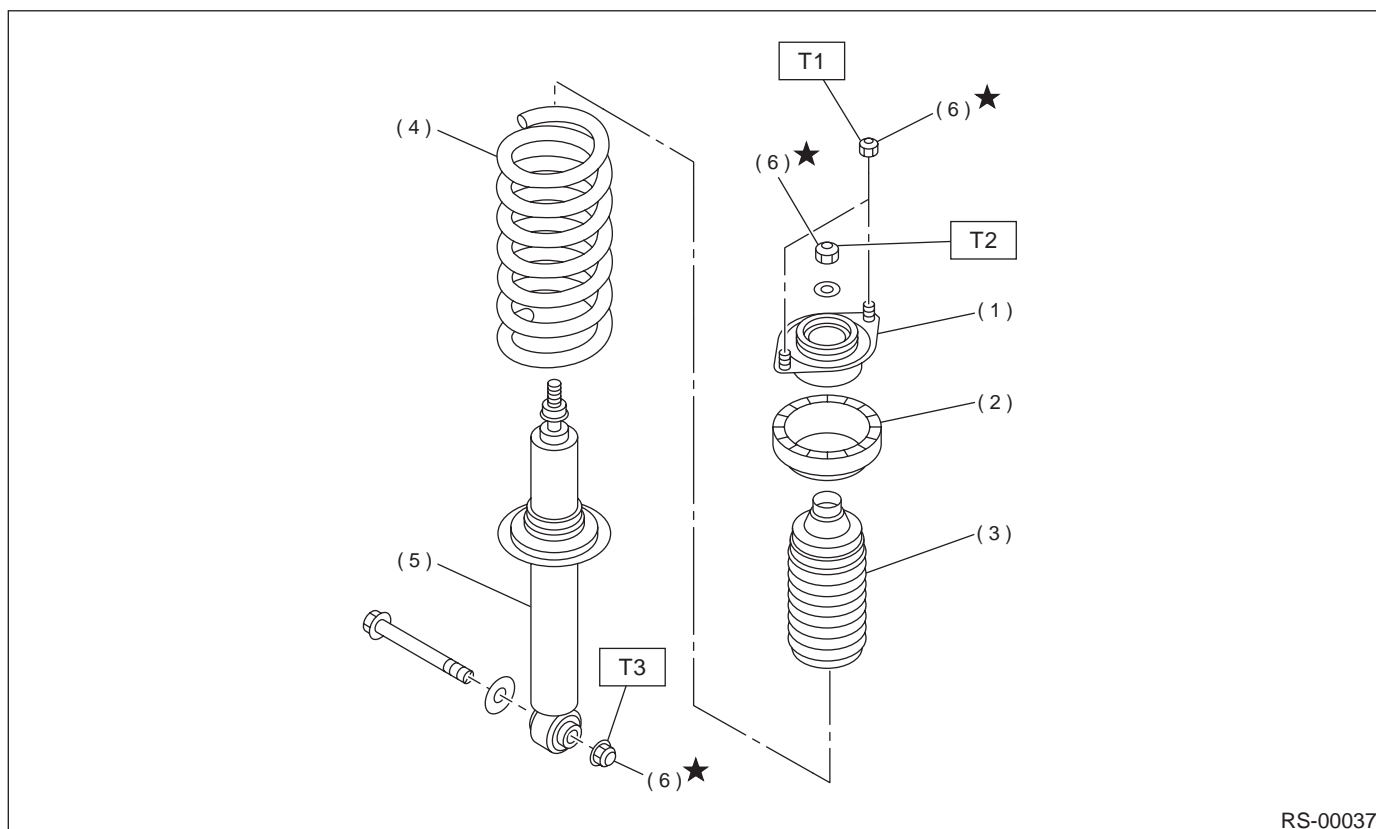

- | | |
|-----------------------|----------------------|
| (1) Mount | (4) Coil spring |
| (2) Rubber seat upper | (5) Shock absorber |
| (3) Dust cover | (6) Self-locking nut |

Tightening torque: N·m (kgf·m, ft·lb)

T1: 30 (3.1, 22.4)

T2: 35 (3.6, 26)

T3: 160 (16.3, 118)

RS-4

GENERAL DESCRIPTION

REAR SUSPENSION

C: CAUTION

- Wear working clothing, including a cap, protective goggles, and protective shoes during operation.
- Remove contamination including dirt and corrosion before removal, installation or disassembly.
- Keep the disassembled parts in order and protect them from dust or dirt.
- Before removal, installation or disassembly, be sure to clarify the failure. Avoid unnecessary removal, installation, disassembly, and replacement.
- Use SUBARU genuine grease etc. or the equivalent. Do not mix grease etc. with that of another grade or from other manufacturers.
- Be sure to tighten fasteners including bolts and nuts to the specified torque.
- Place shop jacks or safety stands at the specified points.
- Apply grease onto sliding or revolution surfaces before installation.
- Before installing O-rings or snap rings, apply sufficient amount of grease to avoid damage and deformation.
- Before securing a part on a vise, place cushioning material such as wood blocks, aluminum plate, or shop cloth between the part and the vise.
- Before disposing shock absorbers, be sure to bleed gas completely. Also, do not throw away in fire.

D: PREPARATION TOOL

1. SPECIAL TOOLS

ILLUSTRATION	TOOL NUMBER	DESCRIPTION	REMARKS
<p>ST-927380002</p>	927380002	ADAPTER	Used as an adapter for camber & caster gauge when measuring camber and caster. (1) 28199AC000 PLATE (2) 28199AC010 BOLT
<p>ST20099AE000</p>	20099AE000	INSTALLER & REMOVER	Used for replacing link rear bushing.

RS-5

GENERAL DESCRIPTION

REAR SUSPENSION

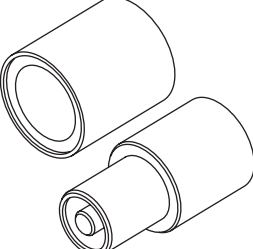
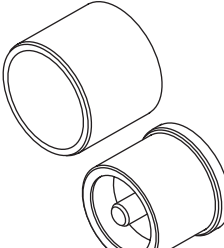
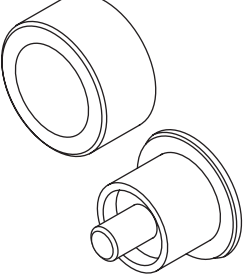
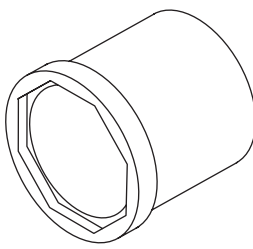
ILLUSTRATION	TOOL NUMBER	DESCRIPTION	REMARKS
 <p style="text-align: center;">ST20099AE010</p>	20099AE010	INSTALLER & REMOVER	Used for replacing link upper bushing.
 <p style="text-align: center;">ST20099AE020</p>	20099AE020	INSTALLER & REMOVER SET	Used for replacing rear arm front bushing.
 <p style="text-align: center;">ST20099AE040</p>	20099AE040	INSTALLER & REMOVER SET	Used for replacing rear arm rear bushing.
 <p style="text-align: center;">ST20099AE030</p>	20099AE030	HELPER SOCKET WRENCH	Used for replacing helper.

RS-6

GENERAL DESCRIPTION

REAR SUSPENSION

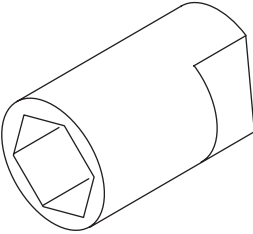
ILLUSTRATION	TOOL NUMBER	DESCRIPTION	REMARKS
 <p>ST-927760000</p>	927760000	STRUT MOUNT SOCKET	Used for disassembling and assembling strut and shock mount.

2. GENERAL PURPOSE TOOLS

TOOL NAME	REMARKS
Alignment gauge	Used for wheel alignment measurement.
Turning radius gauge	Used for wheel alignment measurement.
Toe-in gauge	Used for toe-in measurement.
Transmission jack	Used for suspension assembly/disassembly.
Bearing puller	Used for removing bushings.

RS-7