

SUBARU SELECT MONITOR

VDC (DIAGNOSTICS)

7. Subaru Select Monitor

A: OPERATION

1. READ DIAGNOSTIC TROUBLE CODE

1) Prepare Subaru Select Monitor kit.

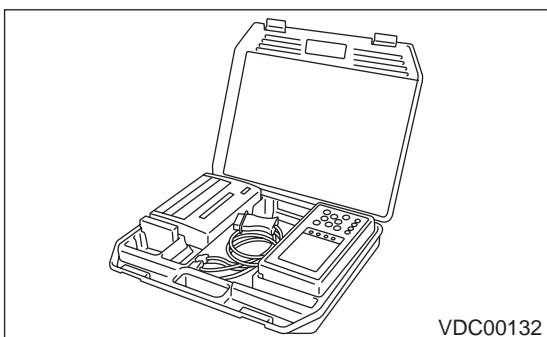

2) Connect diagnosis cable to Subaru Select Monitor.

3) Insert cartridge into Subaru Select Monitor.
<Ref. to VDC-10, SPECIAL TOOLS, PREPARATION TOOL, General Description.>

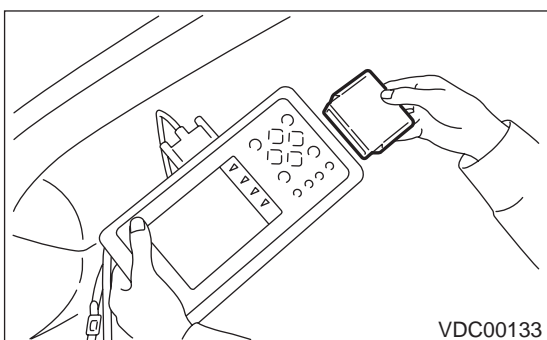

4) Connect Subaru Select Monitor to data link connector.

(1) Data link connector located in the lower portion of the instrument panel (on the driver's side).

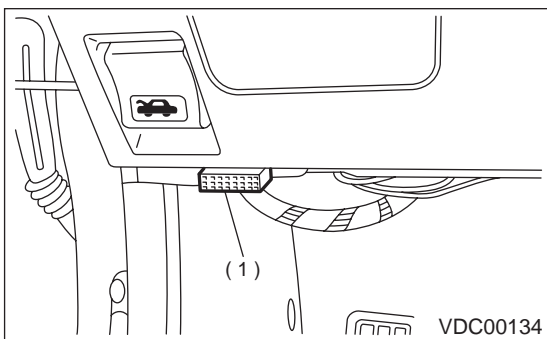

(1) Data link connector

(2) Connect diagnosis cable to data link connector.

5) Turn ignition switch to ON (engine OFF) and Subaru Select Monitor switch to ON.

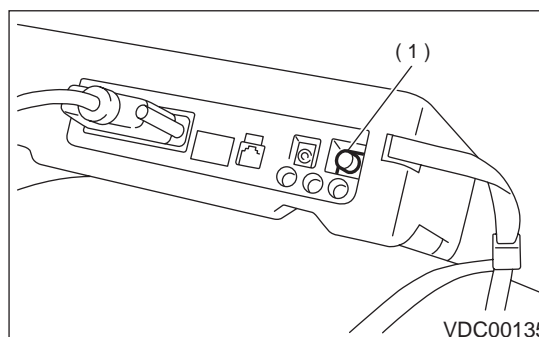

(1) Power switch

6) On the «Main Menu» display screen, select the {Each System Check} and press the [YES] key.

7) On the «System Selection Menu» display screen, select the {Brake Control System} and press the [YES] key.

8) Press the [YES] key after displayed the information of engine type.

9) On the «Brake Diagnosis» display screen, select the {Diagnostic Code(s) Display} and press the [YES] key.

10) On the «Diagnostic Code(s) Display» display screen, select the {Current Diagnostic Code(s)} or {History Diagnostic Code(s)} and press the [YES] key.

NOTE:

- For detailed operation procedure, refer to the SUBARU SELECT MONITOR OPERATION MANUAL.

- For detailed concerning diagnostic trouble codes, refer to the DIAGNOSTIC TROUBLE CODE LIST.

<Ref. to VDC-27, List of Diagnostic Trouble Code (DTC).>

- A maximum of 3 trouble codes are displayed in order of occurrence.

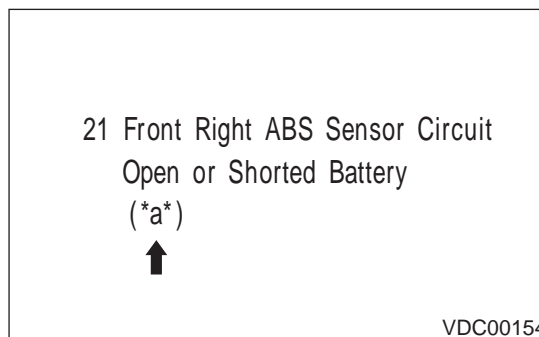

a refers to the troubles in order of occurrence (Latest, Old, Older).

VDC-20

SUBARU SELECT MONITOR

VDC (DIAGNOSTICS)

Display screen	Contents to be monitored
Latest	The most recent trouble code appears on the select monitor display.
Old	The second most recent trouble code appears on the select monitor display.
Older	The third most recent trouble code appears on the select monitor display.

2. READ CURRENT DATA

1) On the «Main Menu» display screen, select {Each System Check} and press the «YES» key.

2) On the «System Selection Menu» display screen, select {Brake Control System} and press «YES» key.

3) Press the «YES» key after the VDC type is displayed.

4) On the «Brake Control Diagnosis» display screen, select {Current Data Display & Save} and press the «YES» key.

5) On the «Data Display Menu» display screen, select {Data Display} and press the «YES» key.

6) Using the scroll key, move the display screen up or down until the desired data is shown.

- A list of the support data is shown in the following table.

Display screen	Contents to be monitored.	Unit of measure
FR wheel speed	Wheel speed detected by the Front Right ABS sensor is displayed.	km/h or MPH
FL wheel speed	Wheel speed detected by the Front Left ABS sensor is displayed.	km/h or MPH
RR wheel speed	Wheel speed detected by the Rear Right ABS sensor is displayed.	km/h or MPH
RL wheel speed	Wheel speed detected by the Rear Left ABS sensor is displayed.	km/h or MPH
Steering angle sensor	Steering wheel angle detected by the steering angle sensor is displayed.	deg
Yaw rate sensor	Vehicle's angular velocity detected by the yaw rate sensor is displayed.	deg/s
Lateral G sensor	Vehicle's lateral acceleration detected by the lateral G sensor is displayed.	V
Pressure sensor 1	Brake fluid pressure detected by the primary pressure sensor is displayed.	V
Pressure sensor 2	Brake fluid pressure detected by the secondary pressure sensor is displayed.	V
Longitudinal G sensor	Longitudinal G sensor is not equipped on vehicles after '00MY. But longitudinal G sensor will remain on monitor and 0 V will be displayed.	V
ABS CM power voltage	Voltage supplied to VDCCM is displayed.	V
Torque driver requires	Engine torque requested by the driver is displayed.	N·m
Current torque	Current engine torque is displayed.	N·m
Valve relay signal	Drive condition of the valve relay is displayed.	ON or OFF
Motor relay signal	Drive condition of the motor relay is displayed.	ON or OFF
VDC OFF lamp	ON operation of the VDC OFF indicator lamp is displayed.	ON or OFF
Motor relay monitor	Operating condition of the motor relay is displayed.	High or Low
PW signal	Accelerator position signal is displayed.	1 or 0
AET signal	Engine control start signal is displayed.	OPEN or GND
AEB signal	Engine control signal is displayed.	OPEN or GND
AEC signal	Engine control signal is displayed.	OPEN or GND
EAM signal	Engine control command signal is displayed.	1 or 0

NOTE:

For detailed operation procedure, refer to the SUBARU SELECT MONITOR OPERATION MANUAL.

VDC-21

SUBARU SELECT MONITOR

VDC (DIAGNOSTICS)

3. CLEAR MEMORY MODE

- 1) On the «Main Menu» display screen, select {2. Each System Check} and press the «YES» key.
- 2) On the «System Select Menu» display screen, select {Brake System} and press the «YES» key.
- 3) Press the «YES» key after the engine type is displayed.

4) On the «Brake Control Diagnosis» display screen, select {Clear Memory} and press the «YES» key.

5) When 'Done' and 'turn ignition switch OFF' are shown on the display screen, turn the Subaru Select Monitor and ignition switch to OFF.

NOTE:

For detailed operation procedure, refer to the SUBARU SELECT MONITOR OPERATION MANUAL.

4. FUNCTION CHECK

Display screen	Contents to be monitored	Index No.
ABS sequence control mode	Perform ABS sequence control by operating valve and pump motor sequentially.	<Ref. to VDC-16, ABS Sequence Control.>
VDC check mode	Perform VDC sequence control by operating valve and pump motor sequentially.	<Ref. to VDC-19, VDC Sequence Control.>
Set mode St. r. A. Sen. N & Lat. G Sen. Op	Set both the neutral position of the steering angle sensor and the zero "0" point of the lateral G sensor.	<Ref. to VDC-26, Steering Angle Sensor.>

VDC-22