

ENGINE MALFUNCTION INDICATOR LAMP (MIL)

ENGINE (DIAGNOSTICS)

16.Engine Malfunction Indicator Lamp (MIL)

A: PROCEDURE

1. Activation of check engine malfunction indicator lamp (MIL). <Ref. to EN(H4SO)-53, ACTIVATION OF CHECK ENGINE MALFUNCTION INDICATOR LAMP (MIL), Engine Malfunction Indicator Lamp (MIL).>
↓
2. Check engine malfunction indicator lamp (MIL) does not come on. <Ref. to EN(H4SO)-54, CHECK ENGINE MALFUNCTION INDICATOR LAMP (MIL) DOES NOT COME ON., Engine Malfunction Indicator Lamp (MIL).>
↓
3. Check engine malfunction indicator lamp (MIL) does not go off. <Ref. to EN(H4SO)-57, CHECK ENGINE MALFUNCTION INDICATOR LAMP (MIL) DOES NOT GO OFF., Engine Malfunction Indicator Lamp (MIL).>
↓
4. Check engine malfunction indicator lamp (MIL) does not blink at a cycle of 3 Hz. <Ref. to EN(H4SO)-58, CHECK ENGINE MALFUNCTION INDICATOR LAMP (MIL) DOES NOT BLINK AT A CYCLE OF 3 HZ., Engine Malfunction Indicator Lamp (MIL).>
↓
5. Check engine malfunction indicator lamp (MIL) remains blinking at a cycle of 3 Hz. <Ref. to EN(H4SO)-60, CHECK ENGINE MALFUNCTION INDICATOR LAMP (MIL) REMAINS BLINKING AT A CYCLE OF 3 HZ., Engine Malfunction Indicator Lamp (MIL).>

ENGINE MALFUNCTION INDICATOR LAMP (MIL)

ENGINE (DIAGNOSTICS)

B: ACTIVATION OF CHECK ENGINE MALFUNCTION INDICATOR LAMP (MIL)

1) When ignition switch is turned to ON (engine off), the CHECK ENGINE malfunction indicator lamp (MIL) in the combination meter illuminates.

NOTE:

If the MIL does not illuminate, perform diagnostics of the CHECK ENGINE light circuit or the combination meter circuit. <Ref. to EN(H4SO)-54, CHECK ENGINE MALFUNCTION INDICATOR LAMP (MIL) DOES NOT COME ON., Engine Malfunction Indicator Lamp (MIL).>

4) When ignition switch is turned to ON (engine off) or to "START" with the test mode connector connected, the MIL blinks at a cycle of 3 Hz.

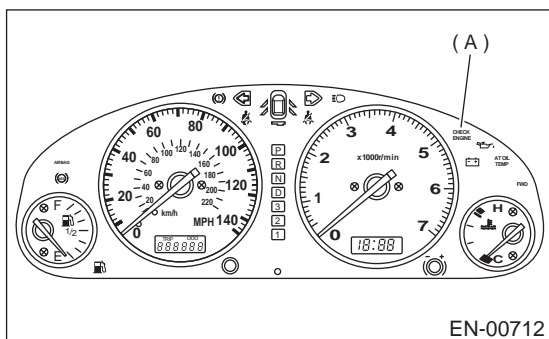
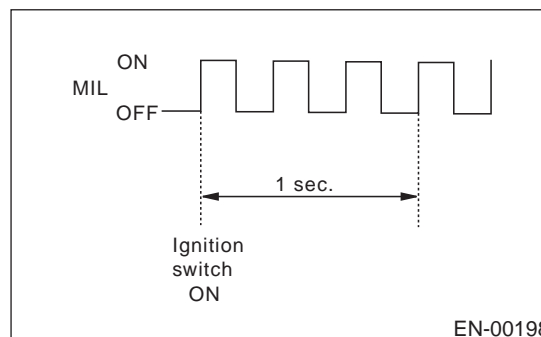

(A) Malfunction indicator lamp (MIL)

2) After starting the engine, the MIL goes out. If it does not, either the engine or the emission control system is malfunctioning.

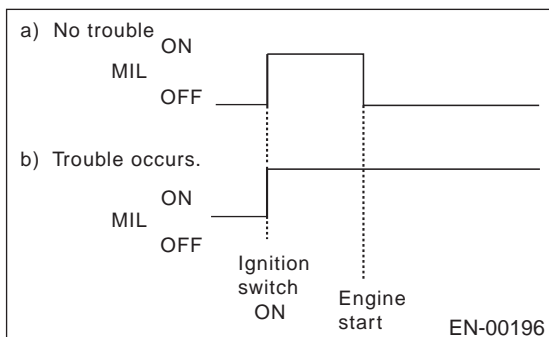

3) If the diagnosis system senses a misfire which could damage the catalyzer, the MIL will blink at a cycle of 1 Hz.

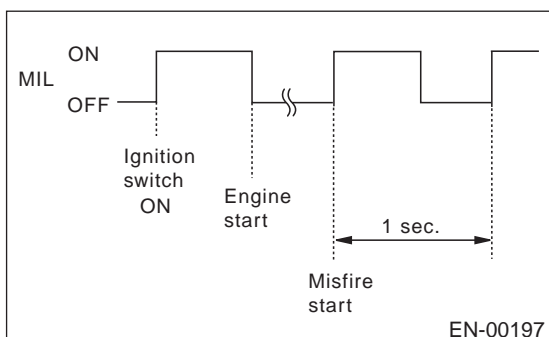

ENGINE MALFUNCTION INDICATOR LAMP (MIL)

ENGINE (DIAGNOSTICS)

C: CHECK ENGINE MALFUNCTION INDICATOR LAMP (MIL) DOES NOT COME ON.

DIAGNOSIS:

- The CHECK ENGINE malfunction indicator lamp (MIL) circuit is open or shorted.

TROUBLE SYMPTOM:

- When ignition switch is turned ON (engine OFF), MIL does not come on.

WIRING DIAGRAM:

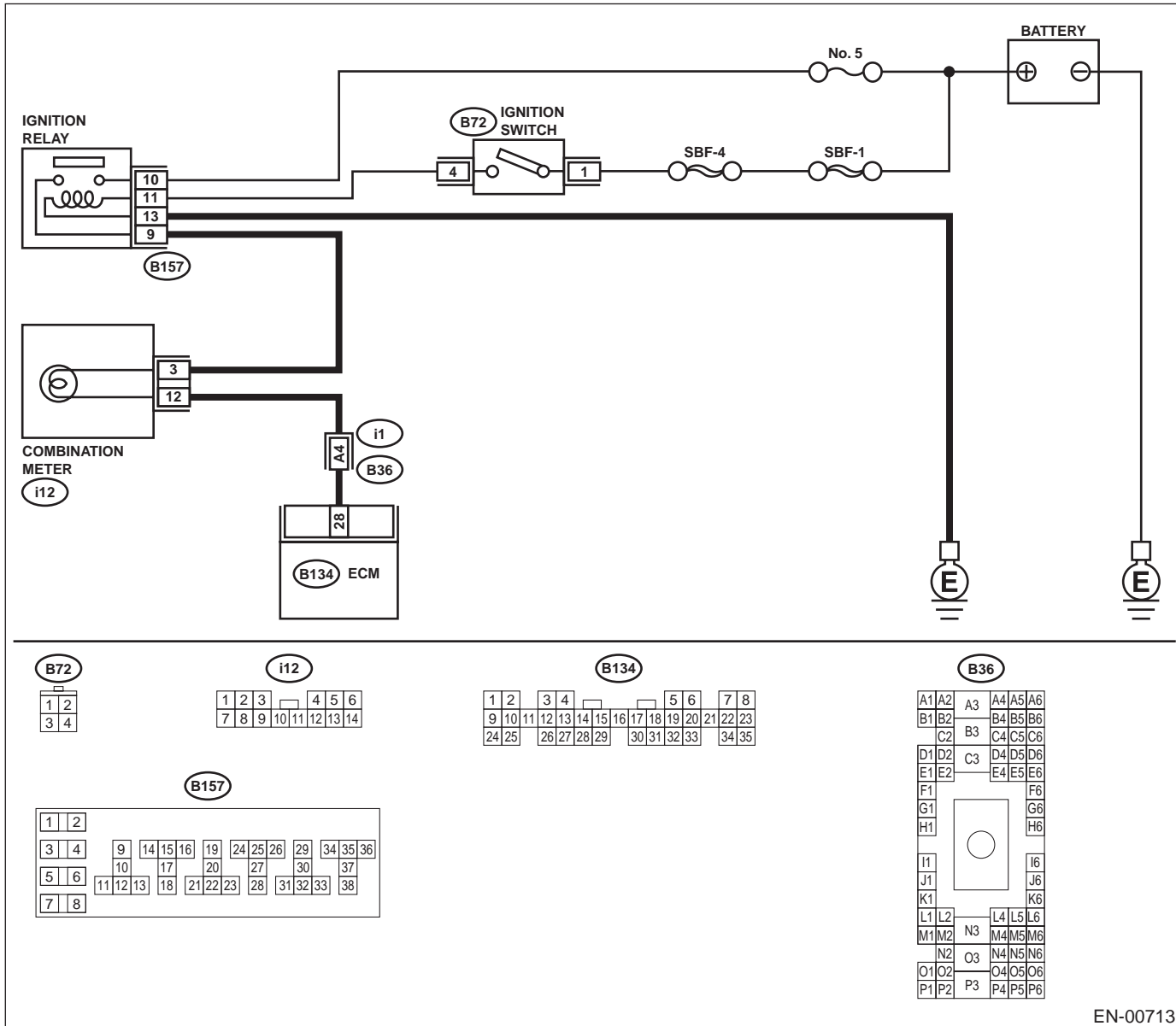

Step	Value	Yes	No
<p>1</p> <p>CHECK OUTPUT SIGNAL FROM ECM.</p> <p>1) Turn ignition switch to ON.</p> <p>2) Measure voltage between ECM connector and chassis ground.</p> <p>Connector & terminal (B134) No. 28 (+) — Chassis ground (-):</p> <p>Is the measured value less than the specified value?</p>	1 V	Go to step 4.	Go to step 2.

ENGINE MALFUNCTION INDICATOR LAMP (MIL)

ENGINE (DIAGNOSTICS)

Step	Value	Yes	No
2 CHECK POOR CONTACT. Does the MIL come on when shaking or pulling ECM connector and harness?	MIL illuminates.	Repair poor contact in ECM connector.	Go to step 3.
3 CHECK ECM CONNECTOR. Is ECM connector correctly connected?	Connected.	Replace ECM. <Ref. to FU(H4SO)-47, Engine Control Module.>	Repair connection of ECM connector.
4 CHECK HARNESS BETWEEN COMBINATION METER AND ECM CONNECTOR. 1) Turn ignition switch to OFF. 2) Remove combination meter. <Ref. to IDI-12, Combination Meter Assembly.> 3) Disconnect connector from ECM and combination meter. 4) Measure resistance of harness between ECM and combination meter connector. Connector & terminal (B134) No. 28 — (i12) No. 12: Is the measured value less than the specified value?	1 Ω	Go to step 5.	Repair harness and connector. NOTE: In this case, repair the following: <ul style="list-style-type: none"> • Open circuit in harness between ECM and combination meter connector • Poor contact in coupling connector
5 CHECK POOR CONTACT. Check poor contact in combination meter connector. Is there poor contact in combination meter connector?	There is poor contact.	Repair poor contact in combination meter connector.	Go to step 6.
6 CHECK HARNESS BETWEEN COMBINATION METER AND IGNITION SWITCH CONNECTOR. 1) Turn ignition switch to ON. 2) Measure voltage between combination meter connector and chassis ground. Connector & terminal (i12) No. 3 (+) — Chassis ground (-): Does the measured value exceed the specified value?	10 V	Go to step 7.	Check the following and repair if necessary. NOTE: <ul style="list-style-type: none"> • Broken down ignition relay. • Blown out fuse (No. 5). • If replaced fuse (No. 5) blows easily, check the harness for short circuit of harness between fuse (No. 5) and ignition relay connector. • Open or short circuit in harness between fuse (No. 5) and battery terminal • Open circuit in harness between fuse (No. 5) and ignition relay connector • Poor contact in ignition relay connector • Poor contact in ignition switch connector

ENGINE MALFUNCTION INDICATOR LAMP (MIL)

ENGINE (DIAGNOSTICS)

	Step	Value	Yes	No
7	CHECK LAMP BULB. Remove engine malfunction indicator lamp bulb. Is lamp bulb condition OK?	OK	Repair combination meter connector.	Replace lamp bulb.

ENGINE MALFUNCTION INDICATOR LAMP (MIL)

ENGINE (DIAGNOSTICS)

D: CHECK ENGINE MALFUNCTION INDICATOR LAMP (MIL) DOES NOT GO OFF.

DIAGNOSIS:

- The CHECK ENGINE malfunction indicator lamp (MIL) circuit is shorted.

TROUBLE SYMPTOM:

- Although MIL comes on when engine runs, trouble code is not shown on Subaru select monitor or OBD-II general scan tool display.

WIRING DIAGRAM:

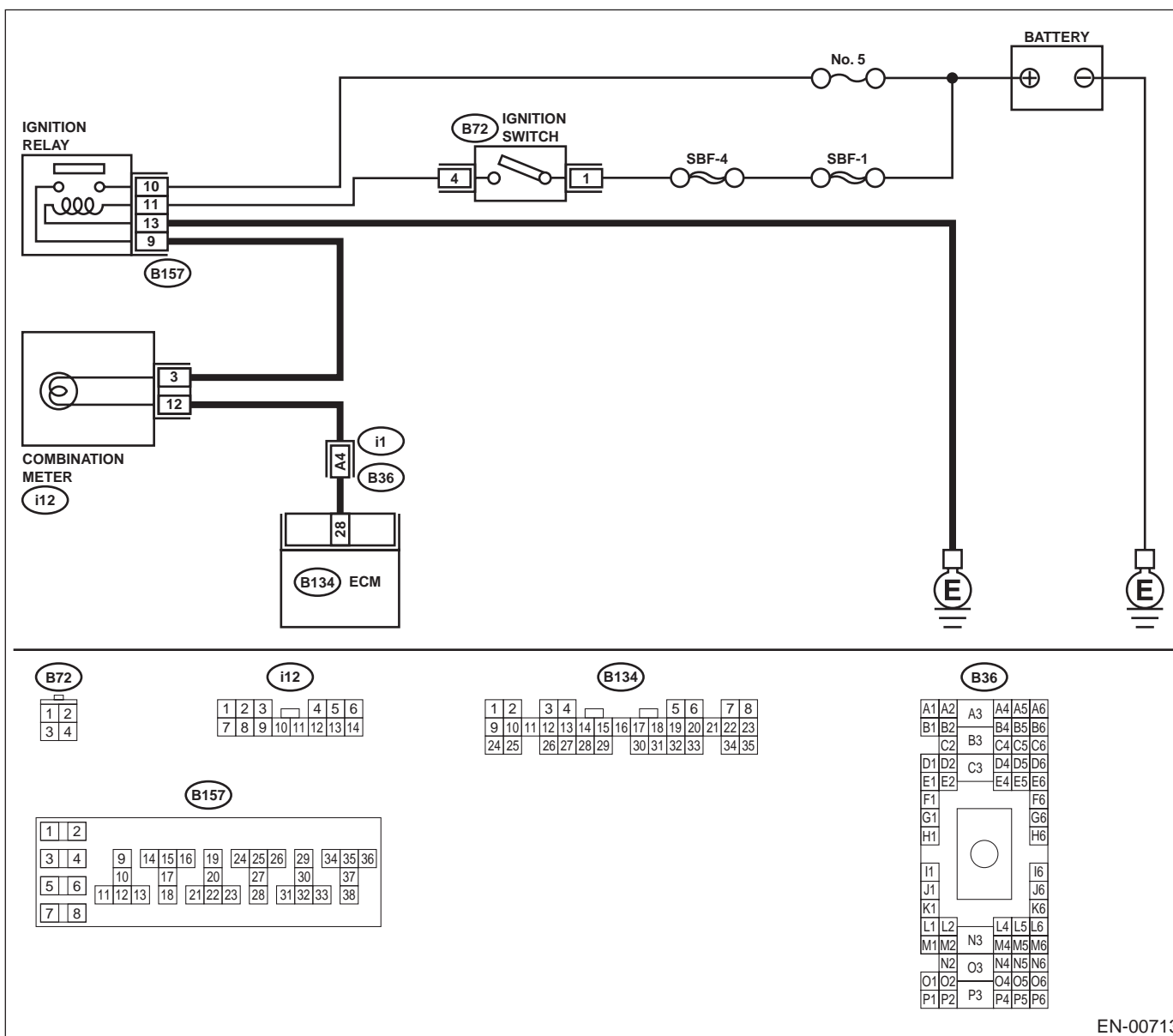

Step	Value	Yes	No
1 CHECK HARNESS BETWEEN COMBINATION METER AND ECM CONNECTOR. 1) Turn ignition switch to OFF. 2) Disconnect connector from ECM. 3) Turn ignition switch to ON. Does the MIL come on?	MIL illuminates.	Repair short circuit in harness between combination meter and ECM connector.	Replace ECM. <Ref. to FU(H4SO)-47, Engine Control Module.>

ENGINE MALFUNCTION INDICATOR LAMP (MIL)

ENGINE (DIAGNOSTICS)

E: CHECK ENGINE MALFUNCTION INDICATOR LAMP (MIL) DOES NOT BLINK AT A CYCLE OF 3 HZ.

- **DIAGNOSIS:**
 - The CHECK ENGINE malfunction indicator lamp (MIL) circuit is open or shorted.
 - Test mode connector circuit is in open.
- **TROUBLE SYMPTOM:**
 - When inspection mode, MIL does not blink at a cycle of 3 Hz.
- **WIRING DIAGRAM:**

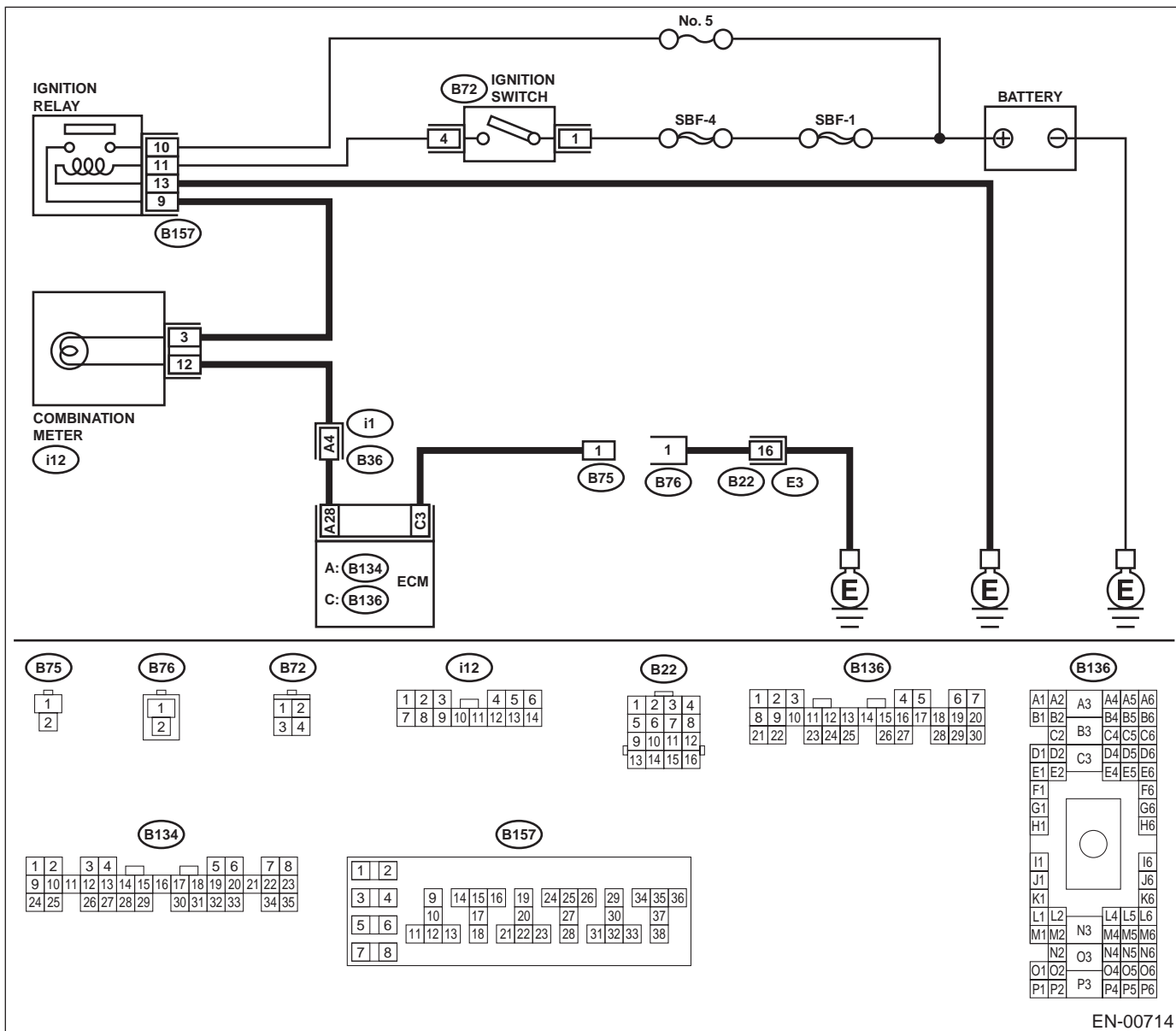

ENGINE MALFUNCTION INDICATOR LAMP (MIL)

ENGINE (DIAGNOSTICS)

Step	Value	Yes	No
1 CHECK STATUS OF CHECK ENGINE MALFUNCTION INDICATOR LAMP (MIL). 1) Turn ignition switch to OFF. 2) Disconnect test mode connector. 3) Turn ignition switch to ON. (engine OFF) Does the MIL come on?	MIL illuminates.	Go to step 2.	Repair the MIL circuit. <Ref. to EN(H4SO)-54, CHECK ENGINE MALFUNCTION INDICATOR LAMP (MIL) DOES NOT COME ON., Engine Malfunction Indicator Lamp (MIL).>
2 CHECK HARNESS BETWEEN COMBINATION METER AND ECM CONNECTOR. 1) Turn ignition switch to OFF. 2) Disconnect connector from ECM. 3) Turn ignition switch to ON. Does the MIL come on?	MIL illuminates.	Repair ground short circuit in harness between combination meter and ECM connector.	Go to step 3.
3 CHECK HARNESS BETWEEN TEST MODE CONNECTOR AND CHASSIS GROUND. 1) Turn ignition switch to OFF. 2) Disconnect connector from ECM. 3) Measure resistance of harness between test mode connector and chassis ground. Connector & terminal (B76) No. 1 — Chassis ground: Is the measured value less than the specified value?	1 Ω	Go to step 4.	Repair harness and connector. NOTE: In this case, repair the following: • Open circuit in harness between test mode connector and chassis ground
4 CHECK POOR CONTACT. Check poor contact in ECM connector. Is there poor contact in ECM connector?	There is poor contact.	Repair poor contact in ECM connector.	Go to step 5.
5 CHECK HARNESS BETWEEN ECM AND TEST MODE CONNECTOR. 1) Connect test mode connector. 2) Measure resistance of harness between ECM and chassis ground. Connector & terminal (B136) No. 3 — Chassis ground: Is the measured value less than the specified value?	1 Ω	Go to step 6.	Repair open circuit in harness between ECM and test mode connector.
6 CHECK POOR CONTACT. Check poor contact in ECM connector. Is there poor contact in ECM connector?	There is poor contact.	Repair poor contact in ECM connector.	Replace ECM. <Ref. to FU(H4SO)-47, Engine Control Module.>

ENGINE MALFUNCTION INDICATOR LAMP (MIL)

ENGINE (DIAGNOSTICS)

F: CHECK ENGINE MALFUNCTION INDICATOR LAMP (MIL) REMAINS BLINKING AT A CYCLE OF 3 HZ.

- **DIAGNOSIS:**
 - Test mode connector circuit is shorted.
- **TROUBLE SYMPTOM:**
 - MIL blinks at a cycle of 3 Hz when ignition switch is turned to ON.
- **WIRING DIAGRAM:**

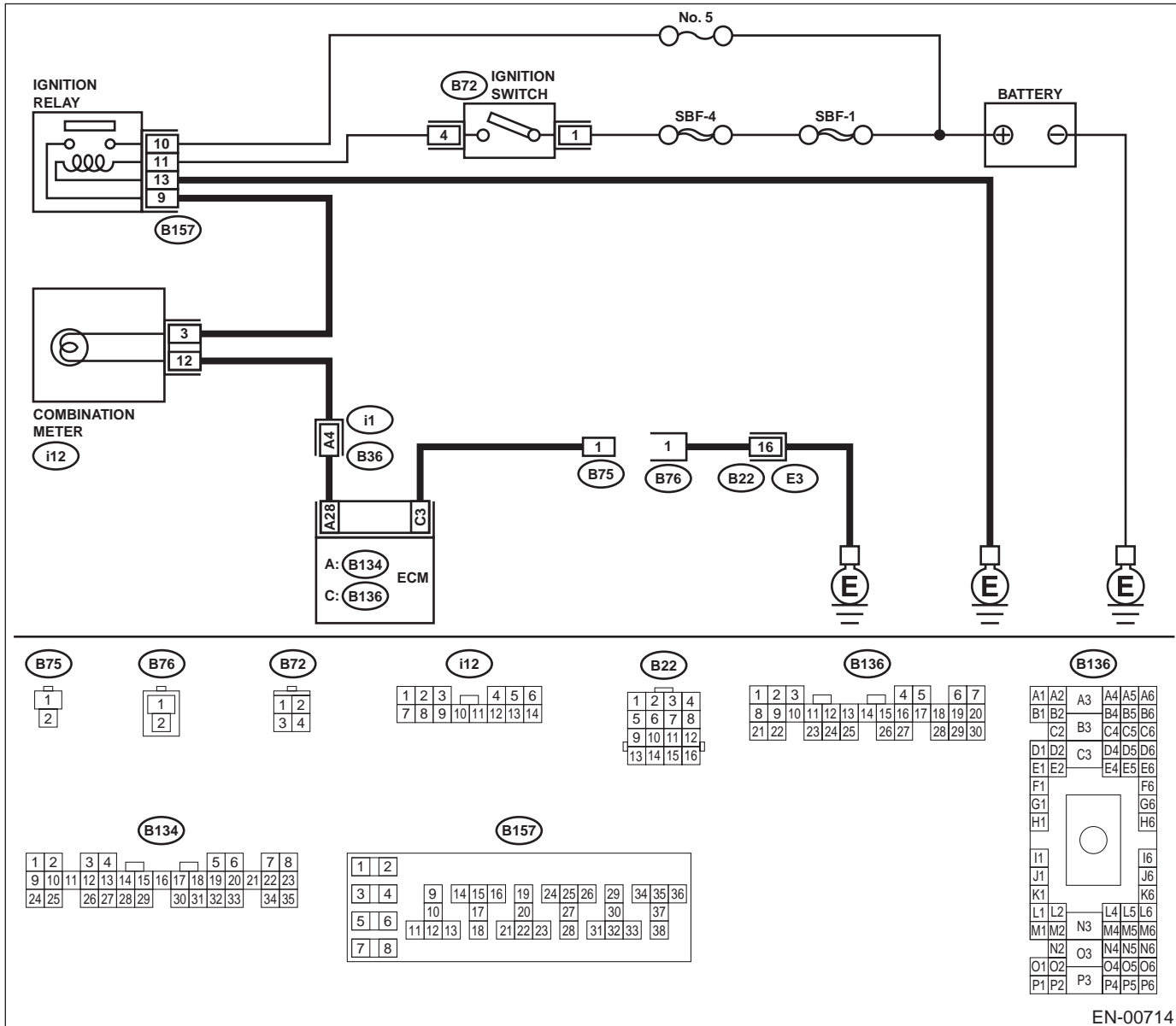

Step	Value	Yes	No
1 CHECK TEST MODE CONNECTOR. 1) Disconnect test mode connector. 2) Turn ignition switch to ON. Does MIL flash on and off?	MIL illuminates.	Go to step 2.	System is in good order. NOTE: MIL blinks at a cycle of 3 Hz when test mode connector is connected.

ENGINE MALFUNCTION INDICATOR LAMP (MIL)

ENGINE (DIAGNOSTICS)

Step	Value	Yes	No
<p>2</p> <p>CHECK HARNESS BETWEEN ECM CONNECTOR AND ENGINE GROUNDING TERMINAL.</p> <p>1) Turn ignition switch to OFF. 2) Disconnect connector from ECM. 3) Measure resistance of harness between ECM connector and chassis ground.</p> <p>Connector & terminal (B136) No. 3 — Chassis ground: Does the measured value exceed the specified value?</p>	1 MΩ	Replace ECM. <Ref. to FU(H4SO)-47, Engine Control Module.>	Repair short circuit in harness between ECM and test mode connector.