

DIAGNOSTICS FOR ENGINE STARTING FAILURE

ENGINE (DIAGNOSTICS)

17. Diagnostics for Engine Starting Failure

A: PROCEDURE

1. Inspection of starter motor circuit. <Ref. to EN(H4SO)-64, STARTER MOTOR CIRCUIT, Diagnostics for Engine Starting Failure.>
↓
2. Inspection of ECM power supply and ground line. <Ref. to EN(H4SO)-68, CONTROL MODULE POWER SUPPLY AND GROUND LINE, Diagnostics for Engine Starting Failure.>
↓
3. Inspection of ignition control system. <Ref. to EN(H4SO)-72, IGNITION CONTROL SYSTEM, Diagnostics for Engine Starting Failure.>
↓
4. Inspection of fuel pump circuit. <Ref. to EN(H4SO)-76, FUEL PUMP CIRCUIT, Diagnostics for Engine Starting Failure.>
↓
5. Inspection of fuel injector circuit. <Ref. to EN(H4SO)-80, FUEL INJECTOR CIRCUIT, Diagnostics for Engine Starting Failure.>

EN(H4SO)-62

DIAGNOSTICS FOR ENGINE STARTING FAILURE

ENGINE (DIAGNOSTICS)

MEMO:

EN(H4SO)-63

DIAGNOSTICS FOR ENGINE STARTING FAILURE

ENGINE (DIAGNOSTICS)

B: STARTER MOTOR CIRCUIT

CAUTION:

After repair or replacement of faulty parts, conduct CLEAR MEMORY MODE <Ref. to EN(H4SO)-49, Clear Memory Mode.> and INSPECTION MODE <Ref. to EN(H4SO)-42, Inspection Mode.> .

• WIRING DIAGRAM:

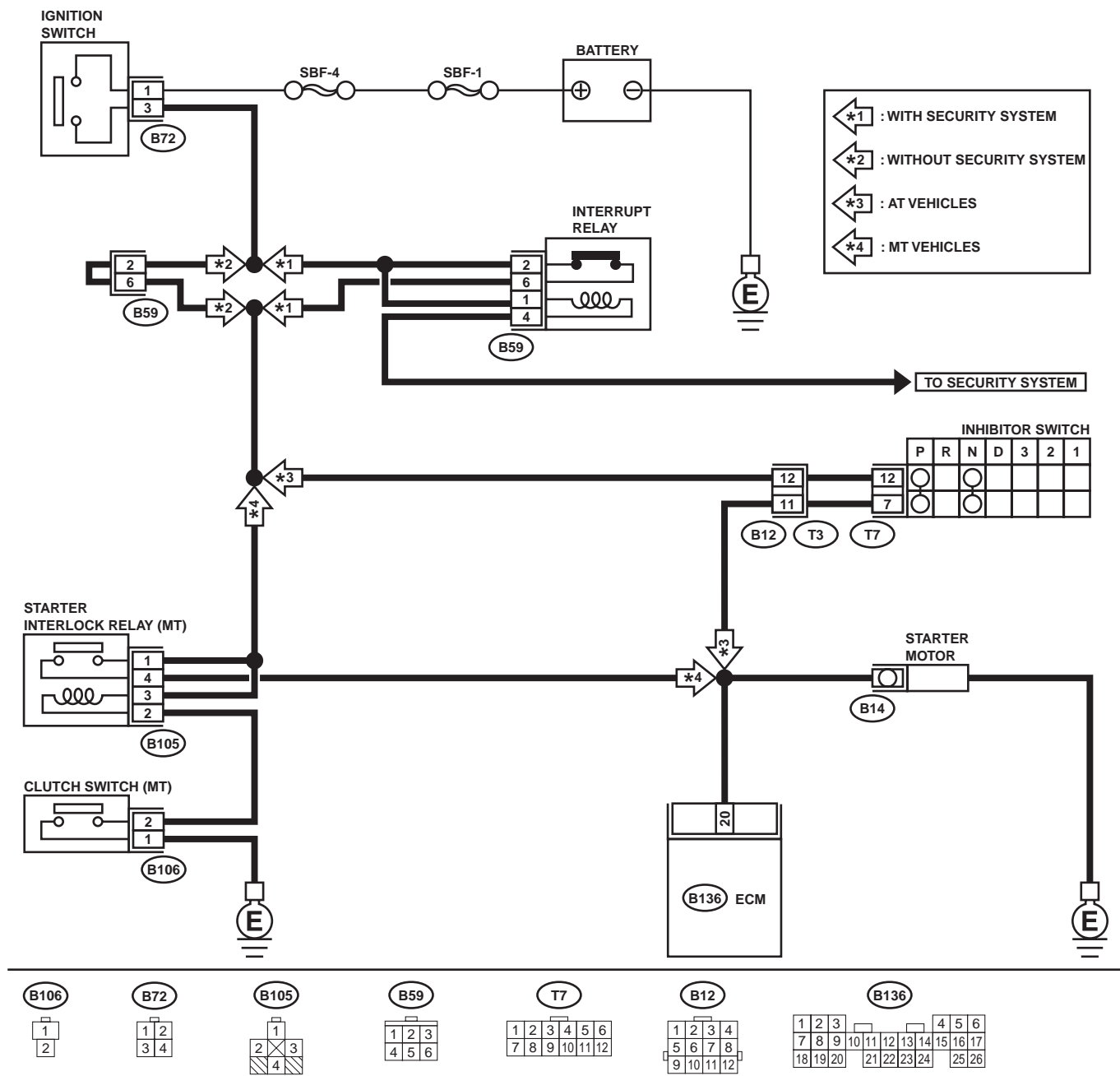

EN-00715

DIAGNOSTICS FOR ENGINE STARTING FAILURE

ENGINE (DIAGNOSTICS)

Step	Value	Yes	No
1 CHECK OPERATION OF STARTER MOTOR. Does the starter motor operates, when the switch is ON?	Operates.	Go to step 2.	Go to step 3.
2 CHECK DTC. Is DTC displayed?	DTC indicated.	Check DTC using "List of Diagnostic Trouble Code (DTC)". <Ref. to EN(H4SO)-82, List of Diagnostic Trouble Code (DTC).>	Repair poor contact in ECM connector.
3 CHECK INPUT SIGNAL FOR STARTER MOTOR. 1) Turn the ignition switch to OFF. 2) Disconnect the connector from starter motor. 3) Turn the ignition switch to ST. 4) Measure the power supply voltage between starter motor connector terminal and engine ground. Connector & terminal (B14) No. 1 (+) — Engine ground (-): Is the measured value more than specified value? NOTE: •On AT vehicles, place the selector lever in the "P" or "N" position. •On MT vehicles, depress the clutch pedal.	10 V	Go to step 4.	Go to step 5.
4 CHECK GROUND CIRCUIT OF STARTER MOTOR. 1) Turn the ignition switch to OFF. 2) Disconnect the terminal from starter motor. 3) Measure the resistance of ground cable between ground cable terminal and engine ground. Is the measured value less than specified value?	5 Ω	Check the starter motor. <Ref. to SC(H4SO)-7, Starter.>	Repair open circuit of ground cable.
5 CHECK HARNESS BETWEEN BATTERY AND IGNITION SWITCH CONNECTOR. 1) Disconnect the connector from ignition switch. 2) Measure the power supply voltage between ignition switch connector and chassis ground. Connector & terminal (B72) No. 1 (+) — Chassis ground (-): Does the measured value exceed the specified value?	10 V	Go to step 6.	Repair open circuit in harness between ignition switch and battery, and check fuse SBF No. 4 and SBF No. 1.
6 CHECK IGNITION SWITCH. 1) Disconnect the connector from ignition switch. 2) Measure the resistance between ignition switch terminals while turning ignition switch to the "ST" position. Terminals No. 1 — No. 3: Is the measured value less than specified value?	5 Ω	Go to step 7.	Replace the ignition switch.

DIAGNOSTICS FOR ENGINE STARTING FAILURE

ENGINE (DIAGNOSTICS)

Step	Value	Yes	No
7 CHECK TRANSMISSION TYPE. Is the target AT vehicle?	Target is AT vehicle.	Go to step 8 .	Go to step 10 .
8 CHECK INPUT VOLTAGE OF INHIBITOR SWITCH. 1) Turn the ignition switch to OFF. 2) Disconnect the connector from inhibitor switch. 3) Connect the connector to ignition switch. 4) Measure the input voltage between inhibitor switch connector terminal and engine ground while turning ignition switch to ST. Connector & terminal (B12) No. 12 (+) — Engine ground (-): Does the measured value exceed the specified value?	10 V	Go to step 9 .	Repair open or ground short circuit in harness between inhibitor switch and ignition switch. NOTE: Check security system (if equipped). <Ref. to SL-22, INSPECTION, Security System.>
9 CHECK INHIBITOR SWITCH. 1) Place the selector lever in the "P" or "N" position. 2) Measure the resistance between inhibitor switch terminals. Connector & terminal (T3) No. 11 — No. 12: Is the measured value less than specified value?	1 Ω	Repair open or ground short circuit in harness between inhibitor switch and starter motor.	Replace the inhibitor switch. <Ref. to AT-50, REMOVAL, Inhibitor Switch.>
10 CHECK INPUT VOLTAGE OF STARTER INTERLOCK RELAY. 1) Turn the ignition switch to OFF. 2) Disconnect the connector from starter interlock relay. 3) Connect the connector to ignition switch. 4) Measure the input voltage between starter interlock relay connector and chassis ground while turning ignition switch to ST. Connector & terminal (B225) No. 28 (+) — Chassis ground (-): (B225) No. 26 (+) — Chassis ground (-): Does the measured value exceed the specified value?	10 V	Go to step 11 .	Repair open or ground short circuit in harness between starter interlock relay and ignition switch. NOTE: Check security system (if equipped). <Ref. to SL-22, INSPECTION, Security System.>
11 CHECK STARTER INTERLOCK RELAY. 1) Connect the battery to starter interlock relay terminals No. 26 and No. 24. 2) Measure the resistance between starter interlock relay terminals. Terminals No. 27 — No. 28: Is the measured value less than specified value?	1 Ω	Go to step 12 .	Replace the starter interlock relay.
12 CHECK GROUND CIRCUIT OF CLUTCH SWITCH. 1) Disconnect the connector from clutch switch. 2) Measure the resistance between clutch switch connector and chassis ground. Connector & terminal (B106) No. 1 — Chassis ground: Is the measured value less than specified value?	1 Ω	Go to step 13 .	Repair open circuit of ground cable.

DIAGNOSTICS FOR ENGINE STARTING FAILURE

ENGINE (DIAGNOSTICS)

Step	Value	Yes	No
13 CHECK CLUTCH SWITCH. 1) Measure the resistance between clutch switch terminal while depressing the clutch pedal. Terminals No. 1 — No. 2: Is the measured value less than specified value?	1 Ω	Go to step 14.	Replace the clutch switch. <Ref. to CL-25, REMOVAL, Clutch Switch.>
14 CHECK CLUTCH SWITCH CIRCUIT. 1) Connect the connector to clutch switch. 2) Measure the resistance between starter interlock relay connector and chassis ground while depressing the clutch pedal. Connector & terminal (B225) No. 24 — Chassis ground: Is the measured value less than specified value?	1 Ω	Repair ground short circuit in harness between starter interlock relay and starter motor.	Repair open circuit in harness between starter interlock relay and clutch switch.

DIAGNOSTICS FOR ENGINE STARTING FAILURE

ENGINE (DIAGNOSTICS)

C: CONTROL MODULE POWER SUPPLY AND GROUND LINE

CAUTION:

After repair or replacement of faulty parts, conduct Clear Memory Mode <Ref. to EN(H4SO)-49, OPERATION, Clear Memory Mode.> and Inspection Mode. <Ref. to EN(H4SO)-42, OPERATION, Inspection Mode.>

• **WIRING DIAGRAM:**

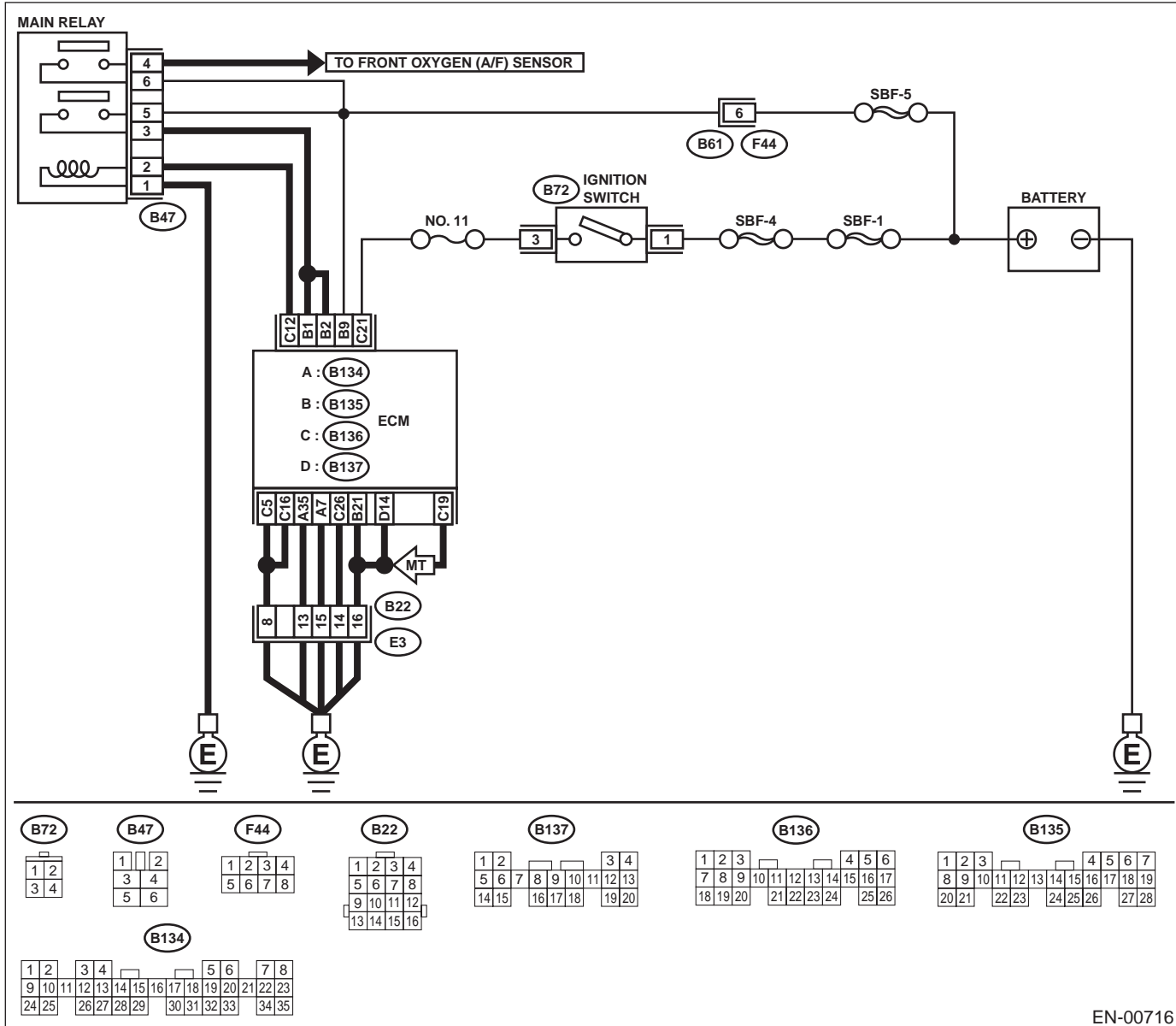

DIAGNOSTICS FOR ENGINE STARTING FAILURE

ENGINE (DIAGNOSTICS)

Step	Value	Yes	No
<p>1 CHECK MAIN RELAY. 1) Turn the ignition switch to OFF. 2) Remove main relay. 3) Connect battery to main relay terminals No. 1 and No. 2. 4) Measure resistance between main relay terminals.</p> <p>Terminals No. 3 — No. 5: No. 4 — No. 6:</p> <p>Is the measured value less than the specified value?</p>	10 Ω	Go to step 2.	Replace main relay.
<p>2 CHECK GROUND CIRCUIT OF ECM. 1) Disconnect connector from ECM. 2) Measure resistance of harness between ECM and chassis ground.</p> <p>Connector & terminal (B134) No. 7 — Chassis ground: (B134) No. 35 — Chassis ground: (B135) No. 21 — Chassis ground: (B136) No. 5 — Chassis ground: (B136) No. 16 — Chassis ground: (B136) No. 26 — Chassis ground: (B137) No. 14 — Chassis ground: (B136) No. 19 — Chassis ground (MT):</p> <p>Is the measured value less than the specified value?</p>	5 Ω	Go to step 3.	Repair open circuit in harness between ECM connector and engine grounding terminal.
<p>3 CHECK INPUT VOLTAGE OF ECM. Measure voltage between ECM connector and chassis ground.</p> <p>Connector & terminal (B135) No. 9 (+) — Chassis ground (-):</p> <p>Does the measured value exceed the specified value?</p>	10 V	Go to step 4.	Repair ground short circuit of power supply circuit.
<p>4 CHECK INPUT VOLTAGE OF ECM. 1) Turn ignition switch to ON. 2) Measure voltage between ECM connector and chassis ground.</p> <p>Connector & terminal (B136) No. 21(+) — Chassis ground (-):</p> <p>Does the measured value exceed the specified value?</p>	10 V	Go to step 5.	Repair open or ground short circuit of power supply circuit.
<p>5 CHECK HARNESS BETWEEN ECM AND MAIN RELAY CONNECTOR. 1) Turn ignition switch to OFF. 2) Measure resistance between ECM and chassis ground.</p> <p>Connector & terminal (B136) No. 12 — Chassis ground:</p> <p>Does the measured value exceed the specified value?</p>	1 MΩ	Go to step 6.	Repair ground short circuit in harness between ECM connector and main relay connector.

DIAGNOSTICS FOR ENGINE STARTING FAILURE

ENGINE (DIAGNOSTICS)

Step	Value	Yes	No
6 CHECK OUTPUT VOLTAGE FROM ECM. 1) Connect connector to ECM. 2) Turn ignition switch to ON. 3) Measure voltage between ECM connector and chassis ground. Connector & terminal (B136) No. 12 (+) — Chassis ground (-): Does the measured value exceed the specified value?	10 V	Go to step 7.	Replace ECM.
7 CHECK INPUT VOLTAGE OF MAIN RELAY. Check voltage between main relay connector and chassis ground. Connector & terminal (B47) No. 2 (+) — Chassis ground (-): Does the measured value exceed the specified value?	10 V	Go to step 8.	Repair open circuit in harness between ECM connector and main relay connector.
8 CHECK GROUND CIRCUIT OF MAIN RELAY. 1) Turn ignition switch to OFF. 2) Measure resistance between main relay connector and chassis ground. Connector & terminal (B47) No. 1 — Chassis ground: Is the measured value less than the specified value?	5 Ω	Go to step 9.	Repair open circuit between main relay and chassis ground.
9 CHECK INPUT VOLTAGE OF MAIN RELAY. Measure voltage between main relay connector and chassis ground. Connector & terminal (B47) No. 5 (+) — Chassis ground (-): (B47) No. 6 (+) — Chassis ground (-): Does the measured value exceed the specified value?	10 V	Go to step 10.	Repair open or ground short circuit in harness of power supply circuit.
10 CHECK INPUT VOLTAGE OF ECM. 1) Connect main relay connector. 2) Turn ignition switch to ON. 3) Measure voltage between ECM connector and chassis ground. Connector & terminal (B135) No. 1 (+) — Chassis ground (-): (B135) No. 2 (+) — Chassis ground (-): Does the measured value exceed the specified value?	10 V	Check ignition control system. <Ref. to EN(H4SO)-72, IGNITION CONTROL SYSTEM, Diagnostics for Engine Starting Failure.>	Repair open or ground short circuit in harness between ECM connector and main relay connector.

DIAGNOSTICS FOR ENGINE STARTING FAILURE

ENGINE (DIAGNOSTICS)

MEMO:

EN(H4SO)-71

DIAGNOSTICS FOR ENGINE STARTING FAILURE

ENGINE (DIAGNOSTICS)

D: IGNITION CONTROL SYSTEM

CAUTION:

After repair or replacement of faulty parts, conduct Clear Memory Mode <Ref. to EN(H4SO)-49, OPERATION, Clear Memory Mode.> and Inspection Mode <Ref. to EN(H4SO)-42, OPERATION, Inspection Mode.> .

• **WIRING DIAGRAM:**

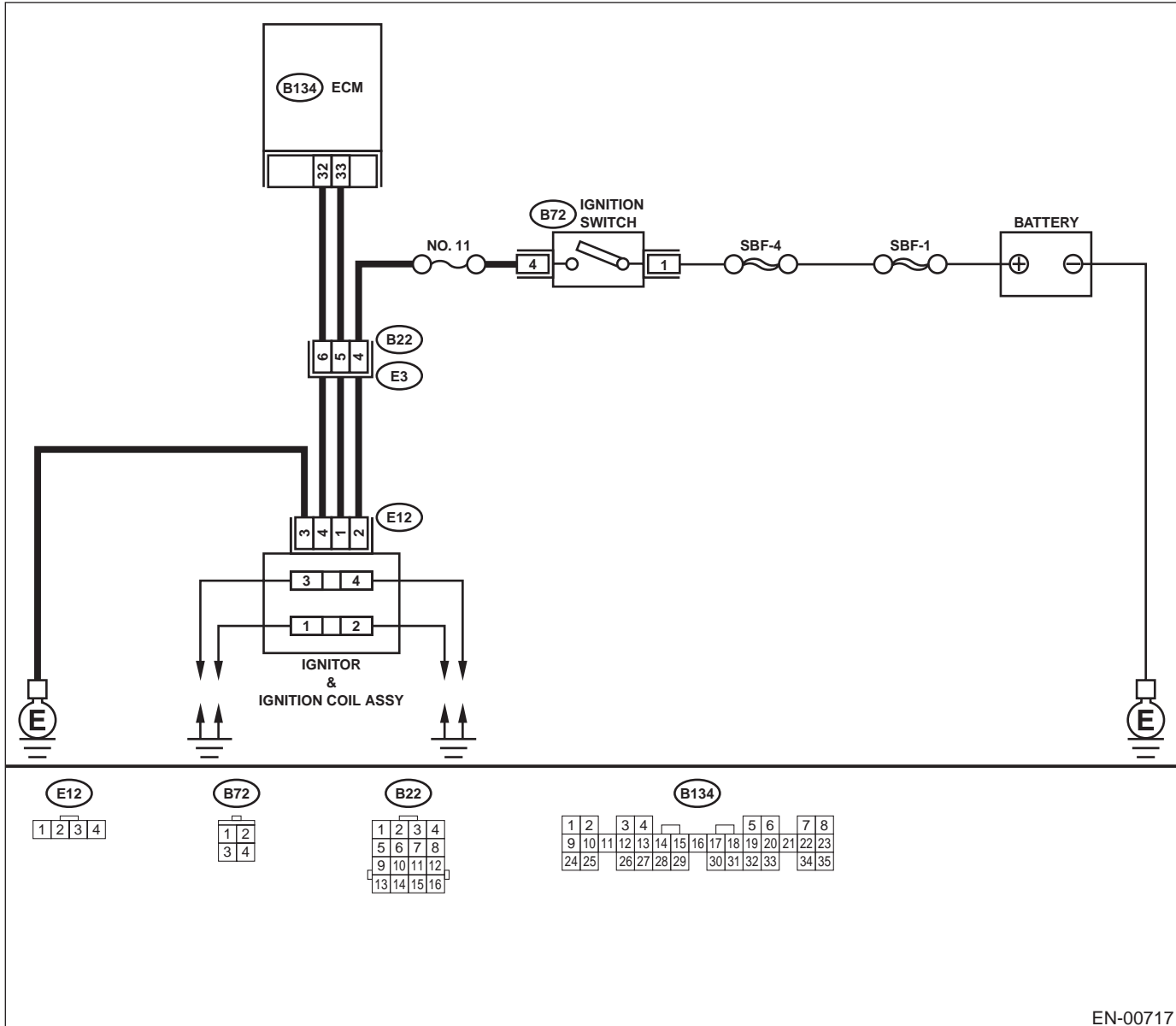

Step	Value	Yes	No
1 CHECK SPARK PLUG CONDITION. 1) Remove the spark plug. <Ref. to IG(H4SO)-4, REMOVAL, Spark Plug.> 2) Check the spark plug condition. <Ref. to IG(H4SO)-5, INSPECTION, Spark Plug.> Is the spark plug's status OK?	OK	Go to step 2.	Replace the spark plug.

DIAGNOSTICS FOR ENGINE STARTING FAILURE

ENGINE (DIAGNOSTICS)

Step	Value	Yes	No
<p>2</p> <p>CHECK IGNITION SYSTEM FOR SPARKS.</p> <p>1) Remove plug cord cap from each spark plug.</p> <p>2) Install new spark plug on plug cord cap.</p> <p>CAUTION: Do not remove spark plug from engine.</p> <p>3) Contact spark plug's thread portion on engine.</p> <p>4) While opening throttle valve fully, crank engine to check that spark occurs at each cylinder.</p> <p>Does spark occur at each cylinder?</p>	Spark occurs.	Check fuel pump system. <Ref. to EN(H4SO)-76, FUEL PUMP CIRCUIT, Diagnostics for Engine Starting Failure.>	Go to step 3.
<p>3</p> <p>CHECK POWER SUPPLY CIRCUIT FOR IGNITION COIL & IGNITOR ASSEMBLY.</p> <p>1) Turn ignition switch to OFF.</p> <p>2) Disconnect connector from ignition coil & ignitor assembly.</p> <p>3) Turn ignition switch to ON.</p> <p>4) Measure power supply voltage between ignition coil & ignitor assembly connector and engine ground.</p> <p>Connector & terminal (E12) No. 2 (+) — Engine ground (-):</p> <p>Does the measured value exceed the specified value?</p>	10 V	Go to step 4.	Repair harness and connector. NOTE: In this case, repair the following: • Open circuit in harness between ignition coil & ignitor assembly, and ignition switch connector • Poor contact in coupling connectors
<p>4</p> <p>CHECK HARNESS OF IGNITION COIL & IGNITOR ASSEMBLY GROUND CIRCUIT.</p> <p>1) Turn ignition switch to OFF.</p> <p>2) Measure resistance between ignition coil & ignitor assembly connector and engine ground.</p> <p>Connector & terminal (E12) No. 3 — Engine ground:</p> <p>Is the measured value less than the specified value?</p>	5 Ω	Go to step 5.	Repair harness and connector. NOTE: In this case, repair the following: • Open circuit in harness between ignition coil & ignitor assembly connector and engine grounding terminal
<p>5</p> <p>CHECK IGNITION COIL & IGNITOR ASSEMBLY.</p> <p>1) Remove spark plug cords.</p> <p>2) Measure resistance between spark plug cord contact portions to check secondary coil.</p> <p>Terminals No. 1 — No. 2: No. 3 — No. 4:</p> <p>Is the measured value within the specified range?</p>	10 - 15 kΩ	Go to step 6.	Replace ignition coil & ignitor assembly. <Ref. to IG(H4SO)-7, Ignition Coil and Ignitor Assembly.>

DIAGNOSTICS FOR ENGINE STARTING FAILURE

ENGINE (DIAGNOSTICS)

Step	Value	Yes	No
6 CHECK INPUT SIGNAL FOR IGNITION COIL & IGNITOR ASSEMBLY. 1) Connect connector to ignition coil & ignitor assembly. 2) Check if voltage varies synchronously with engine speed when cranking, while monitoring voltage between ignition coil & ignitor assembly connector and engine ground. Connector & terminal <i>(E12) No. 1 (+) — Engine ground (-):</i> <i>(E12) No. 4 (+) — Engine ground (-):</i> Does the measured value exceed the specified value?	10 V	Go to step 7.	Replace ignition coil & ignitor assembly. <Ref. to IG(H4SO)-7, Ignition Coil and Ignitor Assembly.>
7 CHECK HARNESS BETWEEN ECM AND IGNITION COIL & IGNITOR ASSEMBLY CONNECTOR. 1) Turn ignition switch to OFF. 2) Disconnect connector from ECM. 3) Disconnect connector from ignition coil & ignitor assembly. 4) Measure resistance of harness between ECM and ignition coil & ignitor assembly connector. Connector & terminal <i>(B134) No. 33 — (E12) No. 1:</i> <i>(B134) No. 32 — (E12) No. 4:</i> Is the measured value less than the specified value?	1 Ω	Go to step 8.	Repair harness and connector. NOTE: In this case, repair the following: <ul style="list-style-type: none"> • Open circuit in harness between ECM and ignition coil & ignitor assembly connector • Poor contact in coupling connector
8 CHECK HARNESS BETWEEN ECM AND IGNITION COIL & IGNITOR ASSEMBLY CONNECTOR. Measure resistance of harness between ECM and engine ground. Connector & terminal: <i>(B134) No. 32 — Engine ground:</i> <i>(B134) No. 33 — Engine ground:</i> Does the measured value exceed the specified value?	1 M Ω	Go to step 9.	Repair ground short circuit in harness between ECM and ignition coil & ignitor assembly connector.
9 CHECK POOR CONTACT. Check poor contact in ECM connector. Is there poor contact in ECM connector?	There is poor contact.	Repair poor contact in ECM connector.	Check fuel pump circuit. <Ref. to EN(H4SO)-76, FUEL PUMP CIRCUIT, Diagnostics for Engine Starting Failure.>

DIAGNOSTICS FOR ENGINE STARTING FAILURE

ENGINE (DIAGNOSTICS)

MEMO:

EN(H4SO)-75

DIAGNOSTICS FOR ENGINE STARTING FAILURE

ENGINE (DIAGNOSTICS)

E: FUEL PUMP CIRCUIT

CAUTION:

After repair or replacement of faulty parts, conduct Clear Memory Mode <Ref. to EN(H4SO)-49, OPERATION, Clear Memory Mode.> and Inspection Mode <Ref. to EN(H4SO)-42, OPERATION, Inspection Mode.> .

• **WIRING DIAGRAM:**

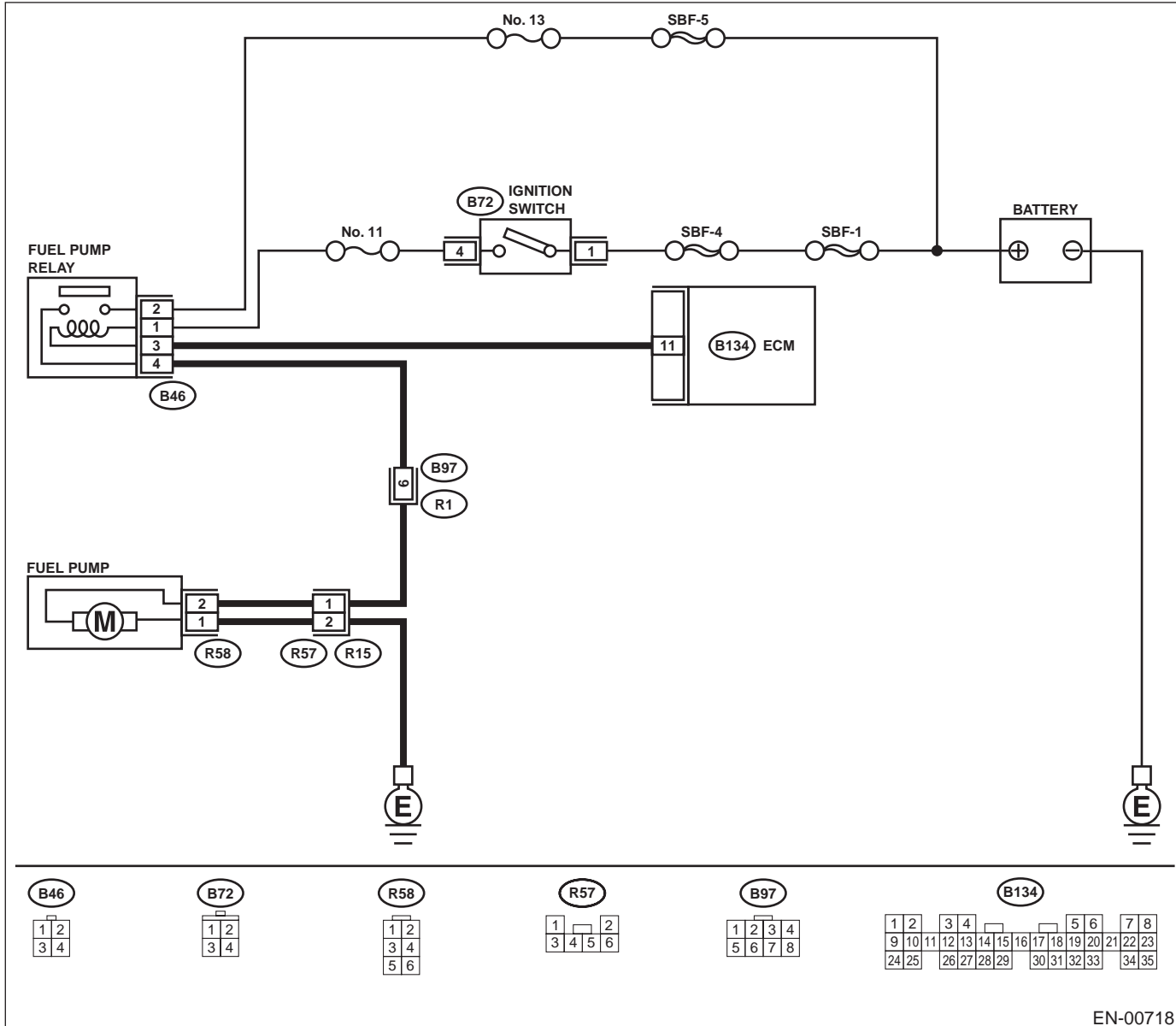

EN-00718

DIAGNOSTICS FOR ENGINE STARTING FAILURE

ENGINE (DIAGNOSTICS)

Step	Value	Yes	No
<p>1 CHECK OPERATING SOUND OF FUEL PUMP. Make sure that fuel pump is in operation for two seconds when turning ignition switch to ON. Does fuel pump produce operating sound? NOTE: Fuel pump operation can also be executed using Subaru Select Monitor (Function mode: FD01). For the procedure, refer to "Compulsory Valve Operation Check Mode". <Ref. to EN(H4SO)-50, Compulsory Valve Operation Check Mode.></p>	Operating sound produced.	Check fuel injector circuit. <Ref. to EN(H4SO)-80, FUEL INJECTOR CIRCUIT, Diagnostics for Engine Starting Failure.>	Go to step 2.
<p>2 CHECK GROUND CIRCUIT OF FUEL PUMP. 1) Turn ignition switch to OFF. 2) Remove fuel pump access hole lid located on the right rear of trunk compartment floor (Sedan) or luggage compartment floor (Wagon). 3) Disconnect connector from fuel pump. 4) Measure resistance of harness connector between fuel pump and chassis ground. Connector & terminal (R58) No. 1 — Chassis ground: Is the measured value less than the specified value?</p>	5 Ω	Go to step 3.	Repair harness and connector. NOTE: In this case, repair the following: • Open circuit in harness between fuel pump connector and chassis grounding terminal • Poor contact in coupling connector
<p>3 CHECK POWER SUPPLY TO FUEL PUMP. 1) Turn ignition switch to ON. 2) Measure voltage of power supply circuit between fuel pump connector and chassis ground. Connector & terminal (R58) No. 2 (+) — Chassis ground (-): Does the measured value exceed the specified value?</p>	10 V	Replace fuel pump. <Ref. to FU(H4SO)-69, Fuel Pump.>	Go to step 4.
<p>4 CHECK HARNESS BETWEEN FUEL PUMP AND FUEL PUMP RELAY CONNECTOR. 1) Turn ignition switch to OFF. 2) Measure resistance of harness connector between fuel pump and fuel pump relay. Connector & terminal (R58) No. 2 — (B46) No. 4: Is the measured value less than the specified value?</p>	1 Ω	Go to step 5.	Repair harness and connector. NOTE: In this case, repair the following: • Open circuit in harness between fuel pump connector and chassis grounding terminal • Poor contact in coupling connectors
<p>5 CHECK HARNESS BETWEEN FUEL PUMP AND FUEL PUMP RELAY CONNECTOR. Measure resistance of harness between fuel pump and fuel pump relay connector. Connector & terminal (R58) No. 2 — Chassis ground: Is the measured value less than the specified value?</p>	1 MΩ	Go to step 6.	Repair short circuit in harness between fuel pump and fuel pump relay connector.

DIAGNOSTICS FOR ENGINE STARTING FAILURE

ENGINE (DIAGNOSTICS)

Step	Value	Yes	No
6 CHECK FUEL PUMP RELAY. 1) Disconnect connectors from fuel pump relay and main relay. 2) Remove fuel pump relay and main relay with bracket. 3) Connect battery to fuel pump relay connector terminals No. 1 and No. 3. 4) Measure resistance between connector terminals of fuel pump relay. Terminals No. 2 — No. 4: Is the measured value less than the specified value?	10 Ω	Go to step 7.	Replace fuel pump relay. <Ref. to FU(H4SO)-49, Fuel Pump Relay.>
7 CHECK HARNESS BETWEEN ECM AND FUEL PUMP RELAY CONNECTOR. 1) Disconnect connectors from ECM. 2) Measure resistance of harness between ECM and fuel pump relay connector. Connector & terminal (B134) No. 11 — (B46) No. 3: Is the measured value less than the specified value?	1 Ω	Go to step 8.	Repair open circuit in harness between ECM and fuel pump relay connector.
8 CHECK POOR CONTACT. Check poor contact in ECM connector. Is there poor contact in ECM connector?	There is poor contact.	Repair poor contact in ECM connector.	Check fuel injector circuit. <Ref. to EN(H4SO)-80, FUEL INJECTOR CIRCUIT, Diagnostics for Engine Starting Failure.>

DIAGNOSTICS FOR ENGINE STARTING FAILURE

ENGINE (DIAGNOSTICS)

MEMO:

EN(H4SO)-79

DIAGNOSTICS FOR ENGINE STARTING FAILURE

ENGINE (DIAGNOSTICS)

F: FUEL INJECTOR CIRCUIT

CAUTION:

- Check or repair only faulty parts.
- After repair or replacement of faulty parts, conduct Clear Memory Mode <Ref. to EN(H4SO)-49, OPERATION, Clear Memory Mode.> and Inspection Mode. <Ref. to EN(H4SO)-42, OPERATION, Inspection Mode.>

• **WIRING DIAGRAM:**

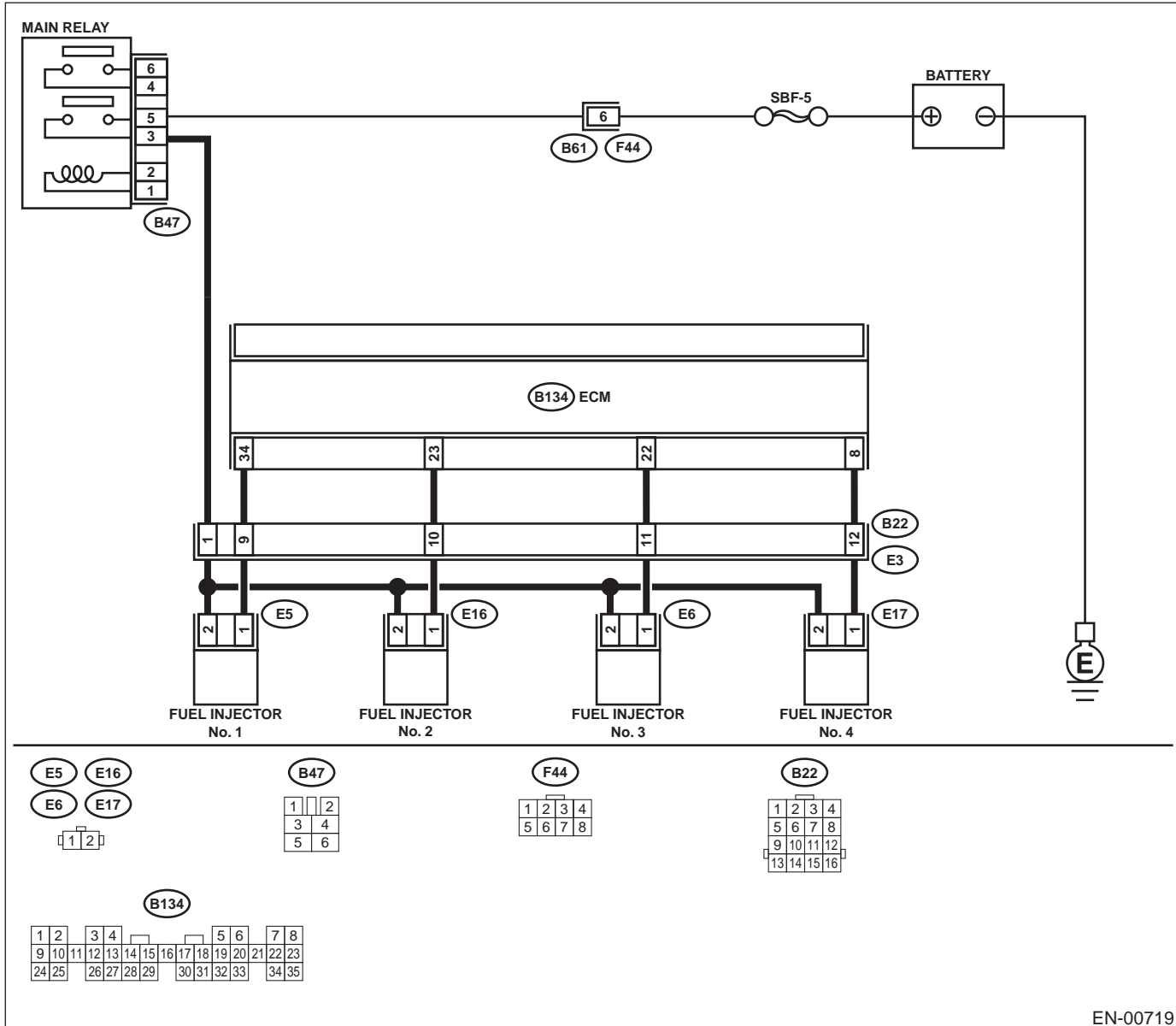

EN-00719

Step	Value	Yes	No
<p>1</p> <p>CHECK OPERATION OF EACH FUEL INJECTOR.</p> <p>While cranking the engine, check that each fuel injector emits "operating" sound. Use a sound scope or attach a screwdriver to injector for this check.</p> <p>Does the fuel injector produce "operating" sound?</p>	<p>Operating sound produced.</p>	<p>Check fuel pressure. <Ref. to ME(H4SO)-28, INSPECTION, Fuel Pressure.></p>	<p>Go to step 2.</p>

DIAGNOSTICS FOR ENGINE STARTING FAILURE

ENGINE (DIAGNOSTICS)

Step	Value	Yes	No
<p>2 CHECK POWER SUPPLY TO EACH FUEL INJECTOR.</p> <p>1) Turn ignition switch to OFF. 2) Disconnect connector from fuel injector. 3) Turn ignition switch to ON. 4) Measure power supply voltage between the fuel injector terminal and engine ground.</p> <p>Connector & terminal #1 (E5) No. 2 (+) — Engine ground (-): #2 (E16) No. 2 (+) — Engine ground (-): #3 (E6) No. 2 (+) — Engine ground (-): #4 (E17) No. 2 (+) — Engine ground (-):</p> <p>Does the measured value exceed the specified value?</p>	10 V	Go to step 3.	<p>Repair harness and connector.</p> <p>NOTE: In this case, repair the following:</p> <ul style="list-style-type: none"> • Open circuit in harness between main relay and fuel injector connector • Poor contact in main relay connector • Poor contact in coupling connector • Poor contact in fuel injector connector
<p>3 CHECK HARNESS BETWEEN ECM AND FUEL INJECTOR CONNECTOR.</p> <p>1) Disconnect connector from ECM and fuel injector. 2) Measure resistance of harness between ECM and fuel injector connector.</p> <p>Connector & terminal (B134) No. 34 — (E5) No. 1: (B134) No. 23 — (E16) No. 1: (B134) No. 22 — (E6) No. 1: (B134) No. 8 — (E17) No. 1:</p> <p>Is the measured value less than the specified value?</p>	1 Ω	Go to step 4.	<p>Repair harness and connector.</p> <p>NOTE: In this case, repair the following:</p> <ul style="list-style-type: none"> • Open circuit in harness between ECM and fuel injector connector • Poor contact in coupling connector
<p>4 CHECK HARNESS BETWEEN ECM AND FUEL INJECTOR CONNECTOR.</p> <p>Measure resistance of harness between ECM and fuel injector connector.</p> <p>Connector & terminal (B134) No. 34 — Chassis ground: (B134) No. 23 — Chassis ground: (B134) No. 22 — Chassis ground: (B134) No. 8 — Chassis ground:</p> <p>Does the measured value exceed the specified value?</p>	1 MΩ	Go to step 5.	<p>Repair ground short circuit in harness between ECM and fuel injector connector.</p>
<p>5 CHECK EACH FUEL INJECTOR.</p> <p>1) Turn ignition switch to OFF. 2) Measure resistance between each fuel injector terminals.</p> <p>Terminals No. 1 — No. 2:</p> <p>Is the measured value within the specified range?</p>	5 - 20 Ω	Go to step 6.	<p>Replace faulty fuel injector.</p>
<p>6 CHECK POOR CONTACT.</p> <p>Check poor contact in ECM connector. Is there poor contact in ECM connector?</p>	There is poor contact.	Repair poor contact in ECM connector.	<p>Inspection using "General Diagnostic Table". <Ref. to EN(H4SO)-360, INSPECTION, General Diagnostic Table.></p>