

## FRONT EXHAUST PIPE

EXHAUST

### 2. Front Exhaust Pipe

#### A: REMOVAL

1) Disconnect battery ground cable.

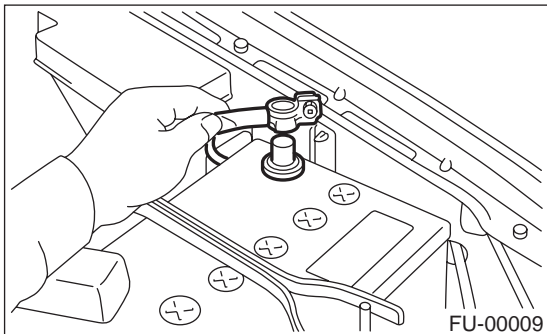

2) Disconnect front oxygen (A/F) sensor connector.

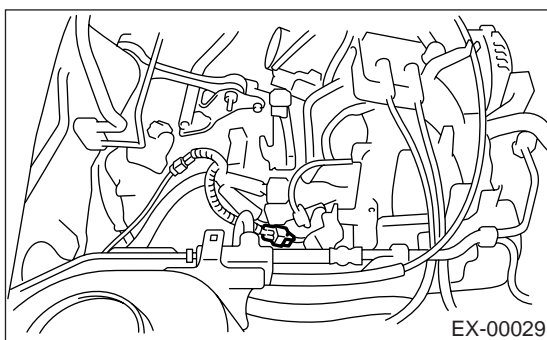

3) Disconnect rear oxygen sensor connector.

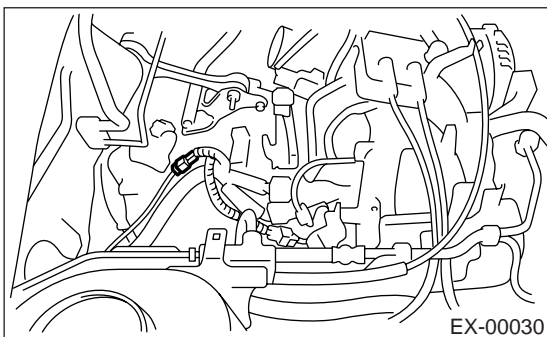

4) Lift-up the vehicle.

5) Separate front and center exhaust pipe assembly from rear exhaust pipe.

#### WARNING:

Be careful, exhaust pipe is hot.

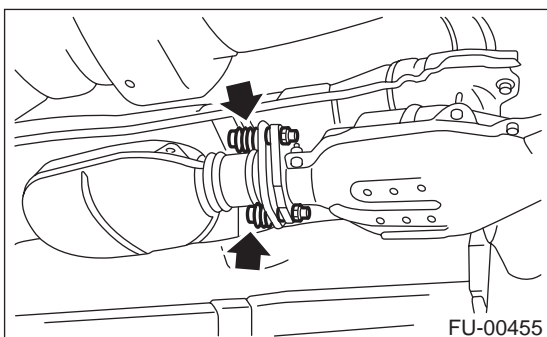

6) Remove under cover.

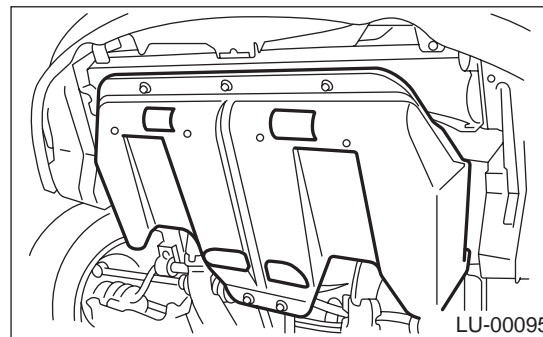

7) Remove nuts which hold front exhaust pipe onto cylinder heads.

#### CAUTION:

Be careful not to pull down front and center exhaust pipe assembly.

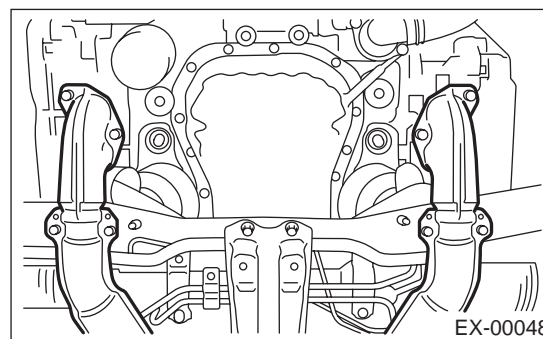

8) Remove bolt which installs front and center exhaust pipe assembly to hanger bracket.

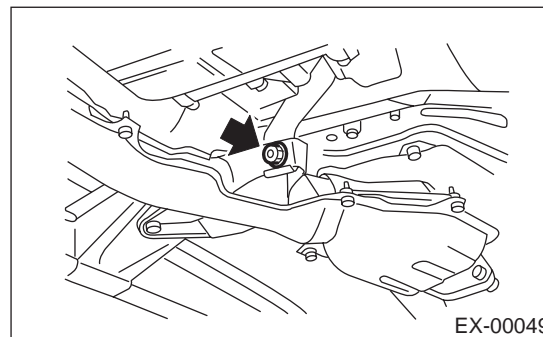

9) Remove front and center exhaust pipe assembly from the vehicle.

#### CAUTION:

- Be careful not to let front and center exhaust pipe assembly fall off when removing as it is quite heavy.
- After removing front and center exhaust assembly, do not apply excessive pulling force on rear exhaust pipe.

EX(H4SO)-5

## FRONT EXHAUST PIPE

### EXHAUST

10) Separate front exhaust pipe from center exhaust pipe.

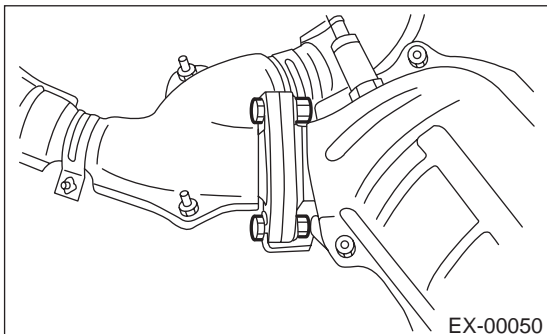

**Tightening torque:**

**30 N·m (3.1 kgf·m, 22.4 ft·lb)**

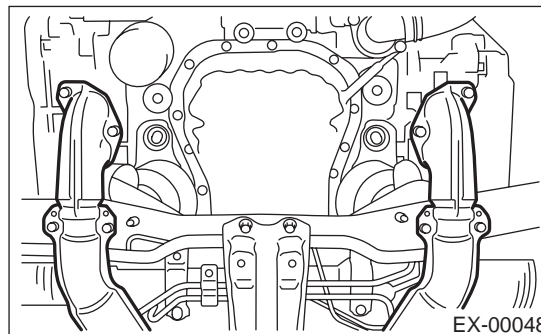

### B: INSTALLATION

1) Install front exhaust pipe to center exhaust pipe.

NOTE:

Replace gaskets with new ones.

**Tightening torque:**

**30 N·m (3.1 kgf·m, 22.4 ft·lb)**

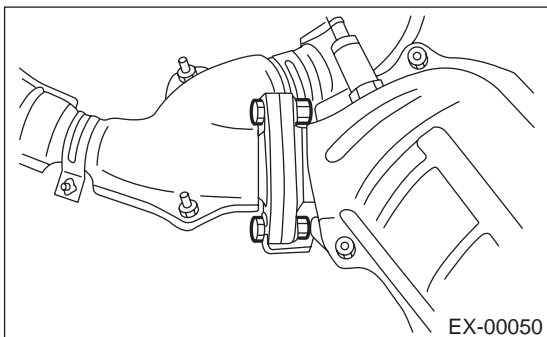

5) Install under cover.

6) Tighten bolts which install front and center exhaust pipe assembly to rear exhaust pipe.

**Tightening torque:**

**18 N·m (1.8 kgf·m, 13.0 ft·lb)**

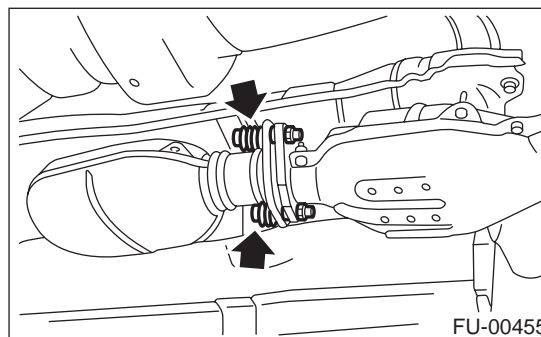

2) Install front and center exhaust pipe assembly to the vehicle.

3) Temporarily tighten bolt which installs front and center exhaust pipe assembly to hanger bracket.

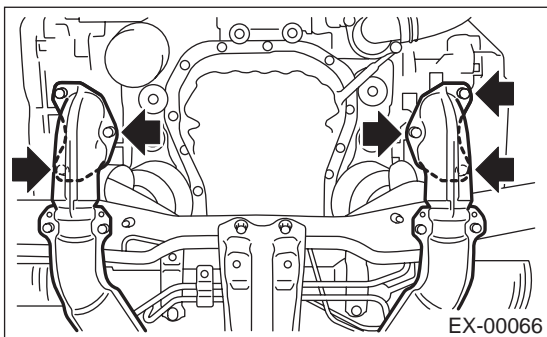

7) Tighten bolt which holds front and center exhaust pipe assembly to hanger bracket.

**Tightening torque:**

**35 N·m (3.6 kgf·m, 26.0 ft·lb)**

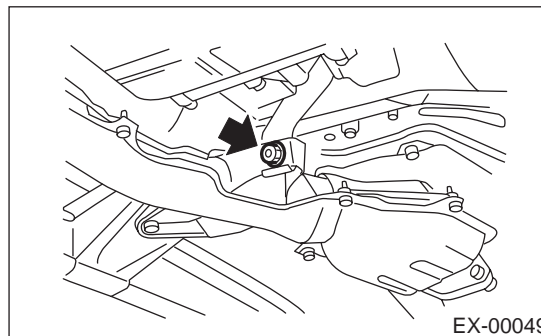

4) Tighten nuts which hold front exhaust pipe onto cylinder heads.

8) Lower the vehicle.

## FRONT EXHAUST PIPE

EXHAUST

9) Connect rear oxygen sensor connector.

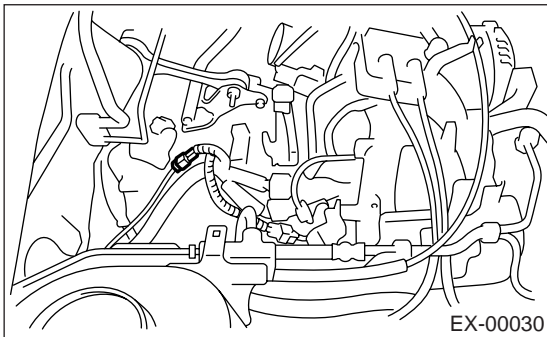

10) Connect front oxygen (A/F) sensor connector.

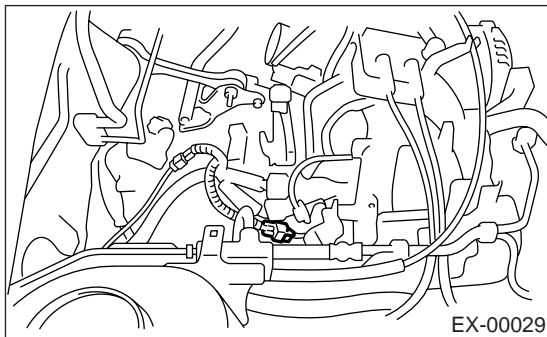

11) Connect battery ground cable.

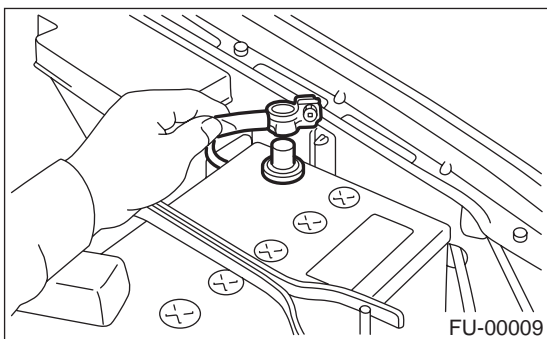

### C: INSPECTION

- 1) Make sure there are no exhaust leaks from connections and welds.
- 2) Make sure there are no holes or rusting.