

IDLE AIR CONTROL SOLENOID VALVE

FUEL INJECTION (FUEL SYSTEMS)

11. Idle Air Control Solenoid Valve

A: REMOVAL

- 1) Disconnect battery ground cable.

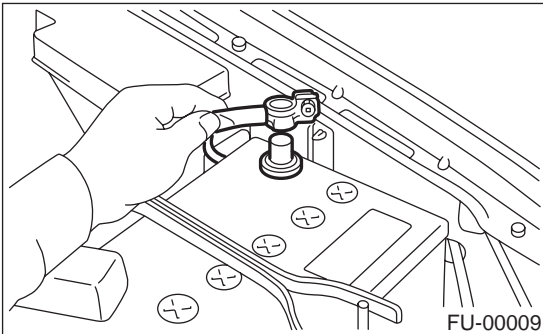

- 2) Disconnect connector from idle air control solenoid valve.

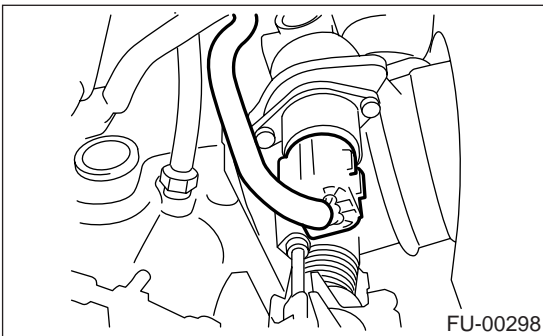

- 3) Remove idle air control solenoid valve from throttle body.

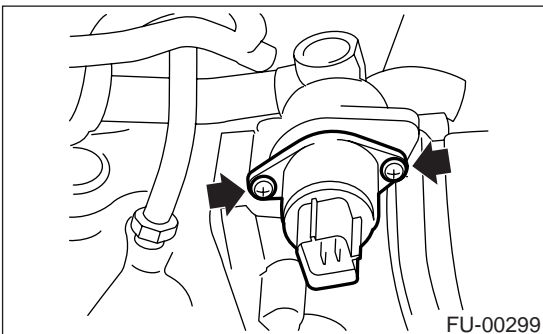

B: INSTALLATION

Install in the reverse order of removal.

NOTE:

Always use a new gasket.

Tightening torque:

2.4 N·m (0.24 kgf-m, 1.7 ft-lb)

