

FUEL INJECTOR

FUEL INJECTION (FUEL SYSTEMS)

14. Fuel Injector

A: REMOVAL

1. RH SIDE

- 1) Release fuel pressure.
<Ref. to FU(H4SO)-50, RELEASING OF FUEL PRESSURE, OPERATION, Fuel.>
- 2) Open fuel flap lid, and remove fuel filler cap.
- 3) Disconnect battery ground cable.

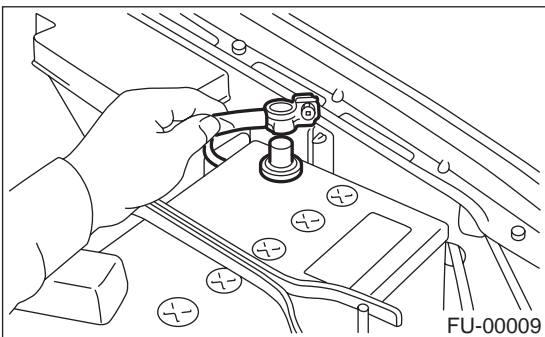

- 4) Remove resonator chamber.
<Ref. to IN(H4SO)-7, REMOVAL, Resonator Chamber.>
- 5) Remove spark plug cords from spark plugs (#1 and #3 cylinders).

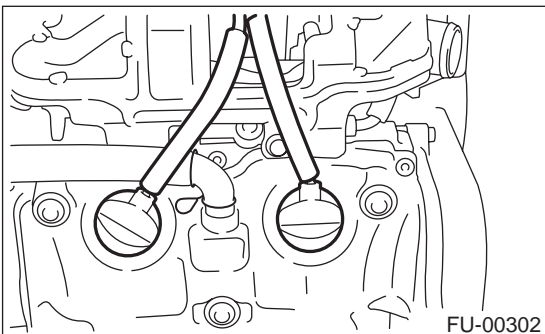

- 6) Remove power steering pump and tank from brackets.

- (1) Remove front V-belt.
<Ref. to ME(H4SO)-42, REMOVAL, V-belt.>

- (2) Remove bolts which hold power steering pipes onto intake manifold protector.

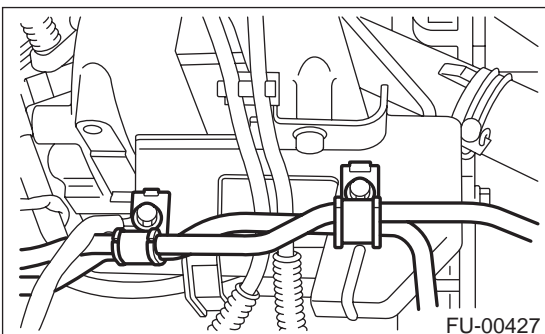

- (3) Remove bolts which install power steering pump to bracket.

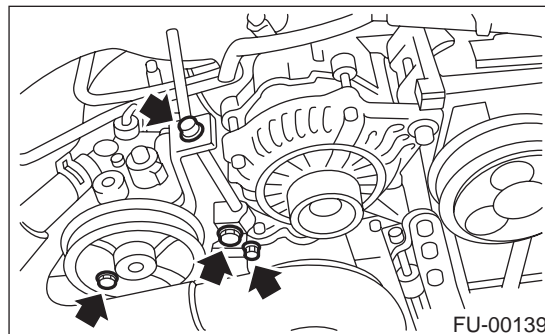

- (4) Disconnect connector from power steering pump switch.

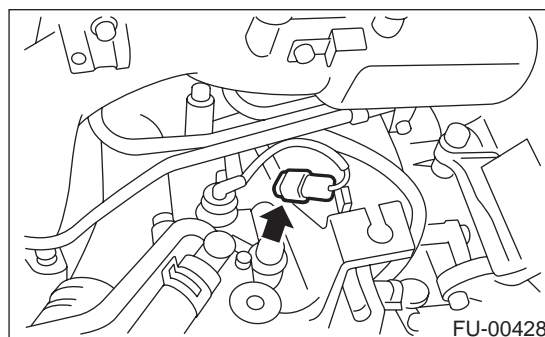

- (5) Remove power steering tank from the bracket by pulling it upwards.

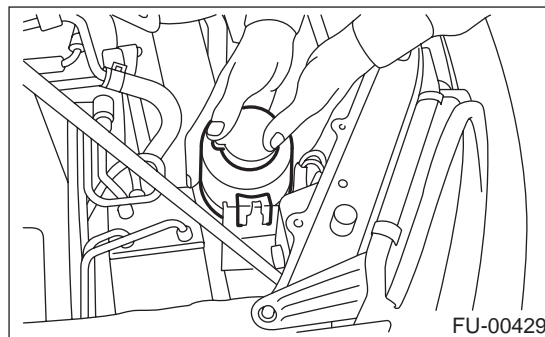

- (6) Place power steering pump and tank on the right side wheel apron.

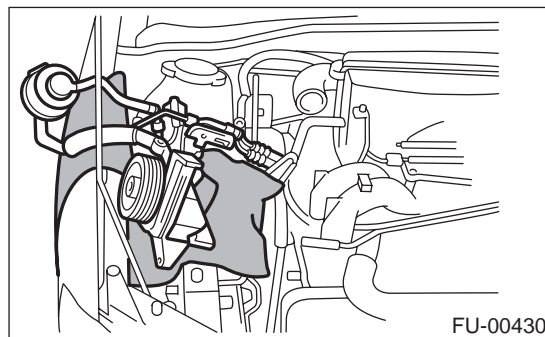

FUEL INJECTOR

FUEL INJECTION (FUEL SYSTEMS)

7) Remove fuel pipe protector RH.

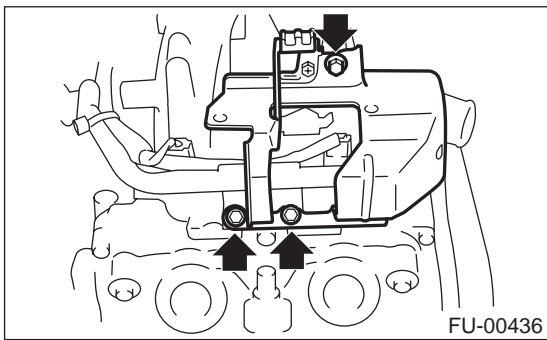

8) Disconnect connector from fuel injector.

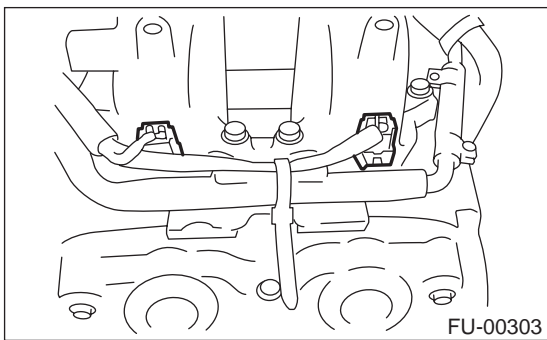

9) Remove bolts which hold injector pipe to intake manifold.

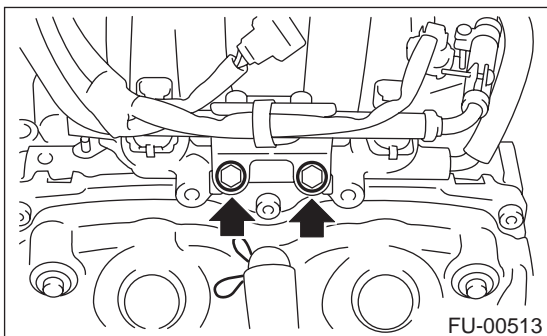

10) Remove bolt which install injector pipe to intake manifold.

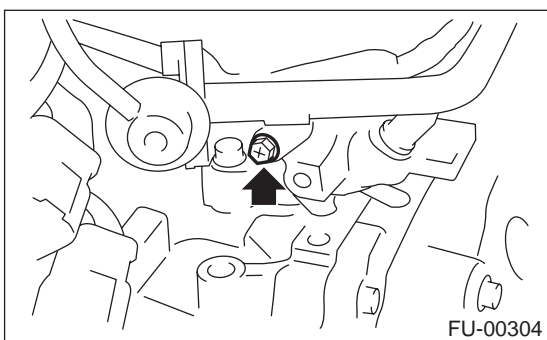

11) Remove fuel injector from intake manifold.

(1) Remove fuel injector securing clip.

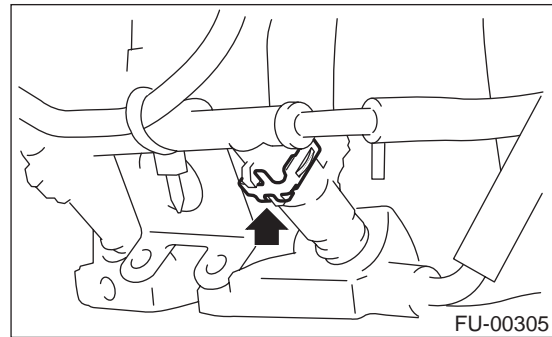

(2) Remove fuel injector while lifting up fuel injector pipe.

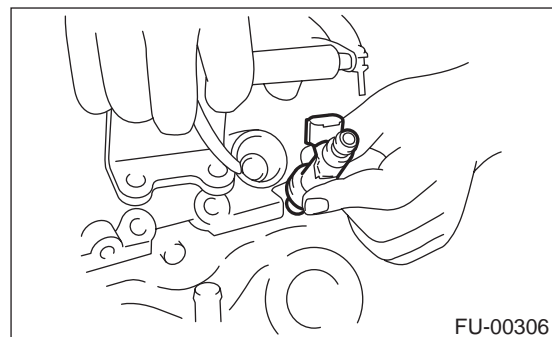

FUEL INJECTOR

FUEL INJECTION (FUEL SYSTEMS)

2. LH SIDE

- 1) Release fuel pressure. <Ref. to FU(H4SO)-50, RELEASING OF FUEL PRESSURE, OPERATION, Fuel.>
- 2) Open fuel flap lid, and remove fuel filler cap.
- 3) Disconnect battery ground cable.

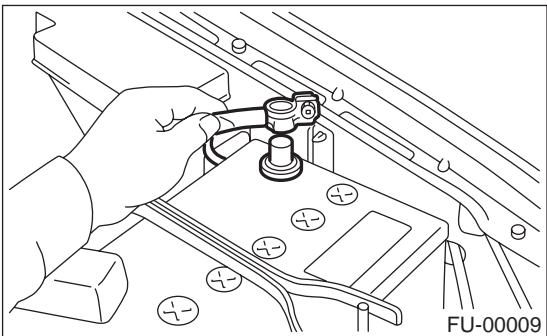

- 4) Remove two bolts which install washer tank on body.

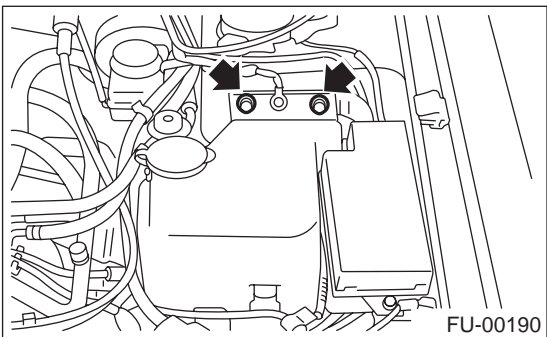

- 5) Disconnect connector from front window washer motor.
- 6) Disconnect connector from rear gate glass washer motor.

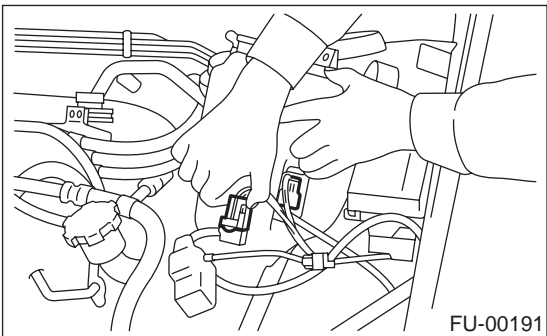

- 7) Disconnect rear window glass washer hose from washer motor, then plug connection with a suitable cap.

- 8) Move washer tank, and secure it away from working area.

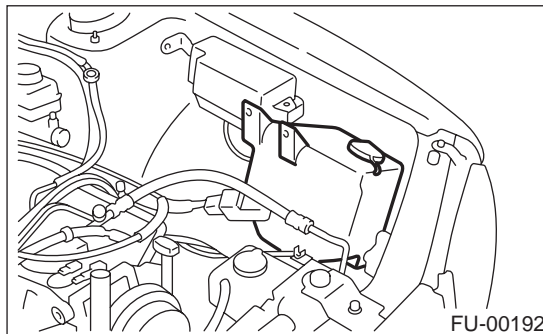

- 9) Remove spark plug cords from spark plugs (#2 and #4 cylinders).

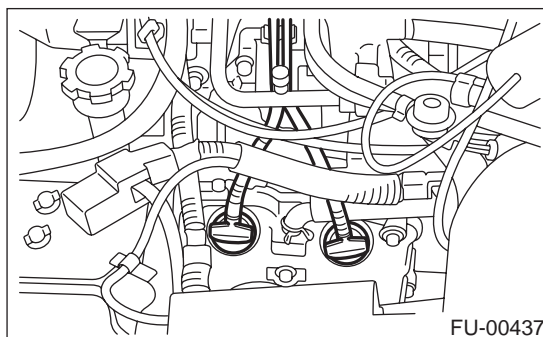

- 10) Remove fuel pipe protector LH.

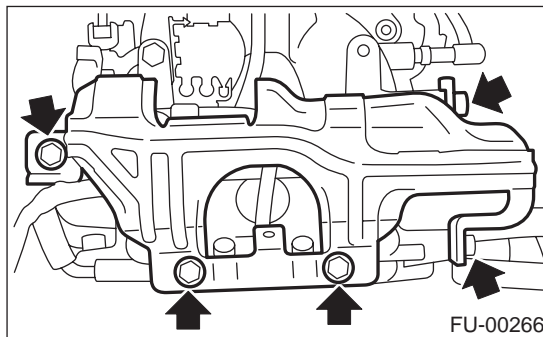

- 11) Disconnect connector from fuel injector.

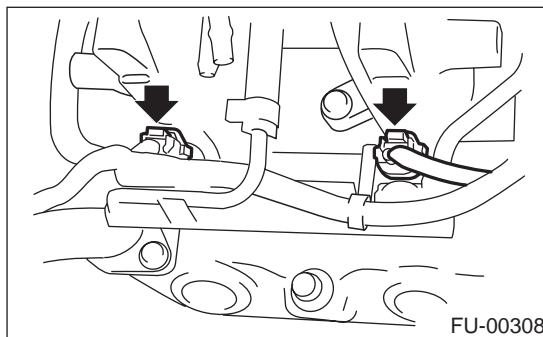

FUEL INJECTOR

FUEL INJECTION (FUEL SYSTEMS)

12) Remove bolt which holds injector pipe to intake manifold.

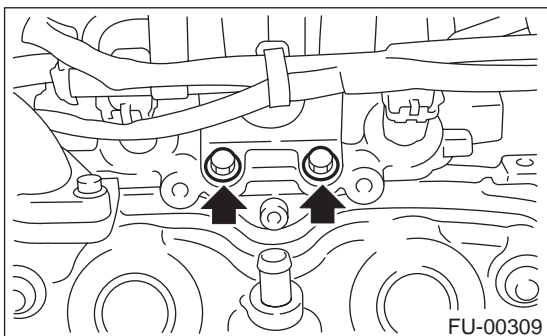

13) Remove bolt which holds fuel pipe on the left side intake manifold.

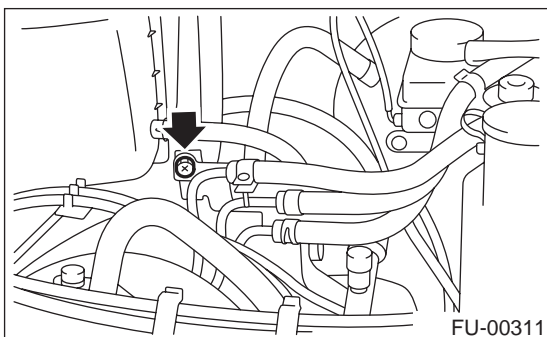

14) Remove fuel injector from intake manifold.
(1) Remove fuel injector securing clip.

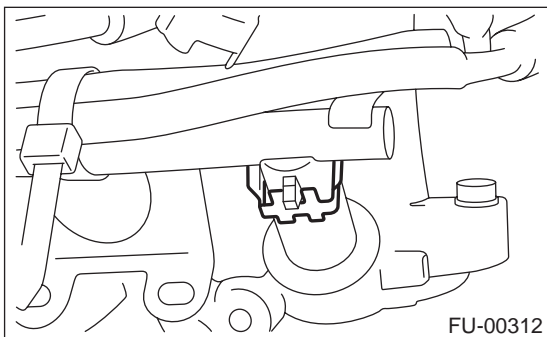

(2) Remove fuel injector while lifting up fuel injector pipe.

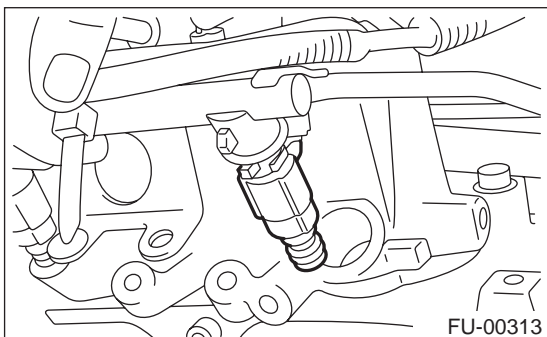

B: INSTALLATION

1. RH SIDE

Install in the reverse order of removal.

NOTE:

Replace O-rings with new ones.

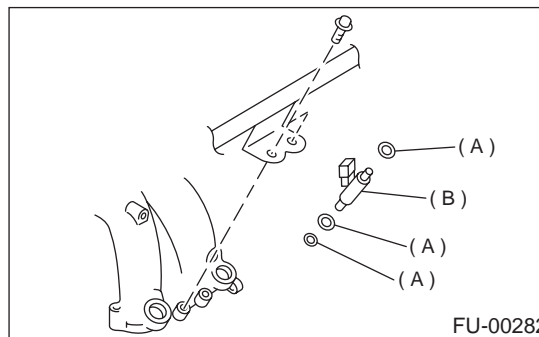

(A) O-ring

(B) Fuel injector

Tightening torque:

5.0 N·m (0.51 kgf-m, 3.7 ft-lb)

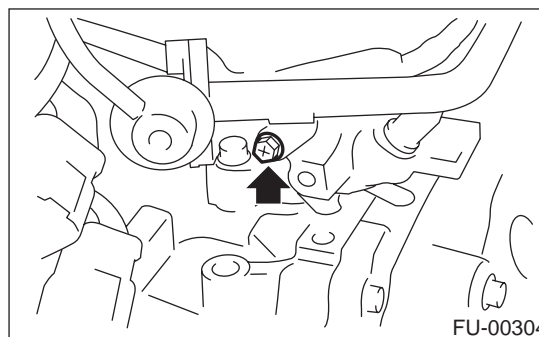

Tightening torque:

19 N·m (0.19 kgf-m, 1.4 ft-lb)

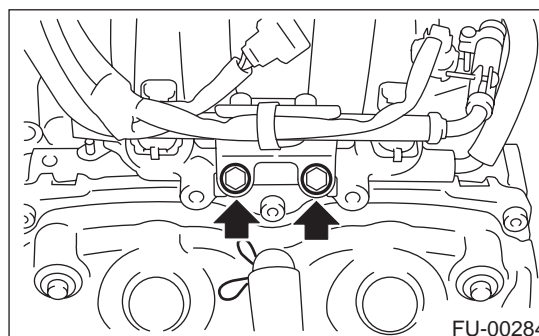

FUEL INJECTOR

FUEL INJECTION (FUEL SYSTEMS)

Tightening torque:

19 N·m (0.19 kgf-m, 1.4 ft-lb)

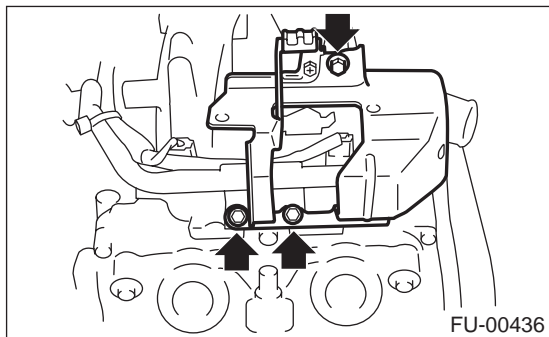

Tightening torque:

19 N·m (1.9 kgf-m, 13.7 ft-lb)

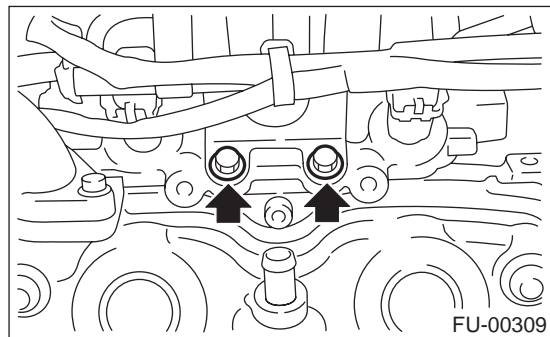

2. LH SIDE

Install in the reverse order of removal.

NOTE:

Replace O-rings with new ones.

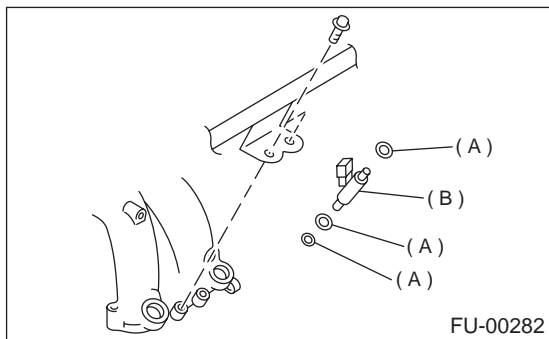

- (A) O-ring
- (B) Fuel injector

Tightening torque:

19 N·m (1.9 kgf-m, 13.7 ft-lb)

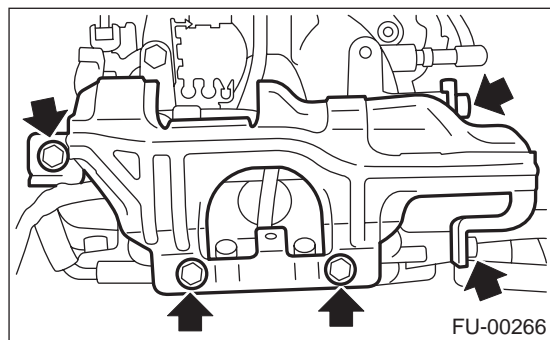

Tightening torque:

5.0 N·m (0.51 kgf-m, 3.7 ft-lb)

