

GENERAL DESCRIPTION

INTAKE (INDUCTION)

1. General Description

A: COMPONENT

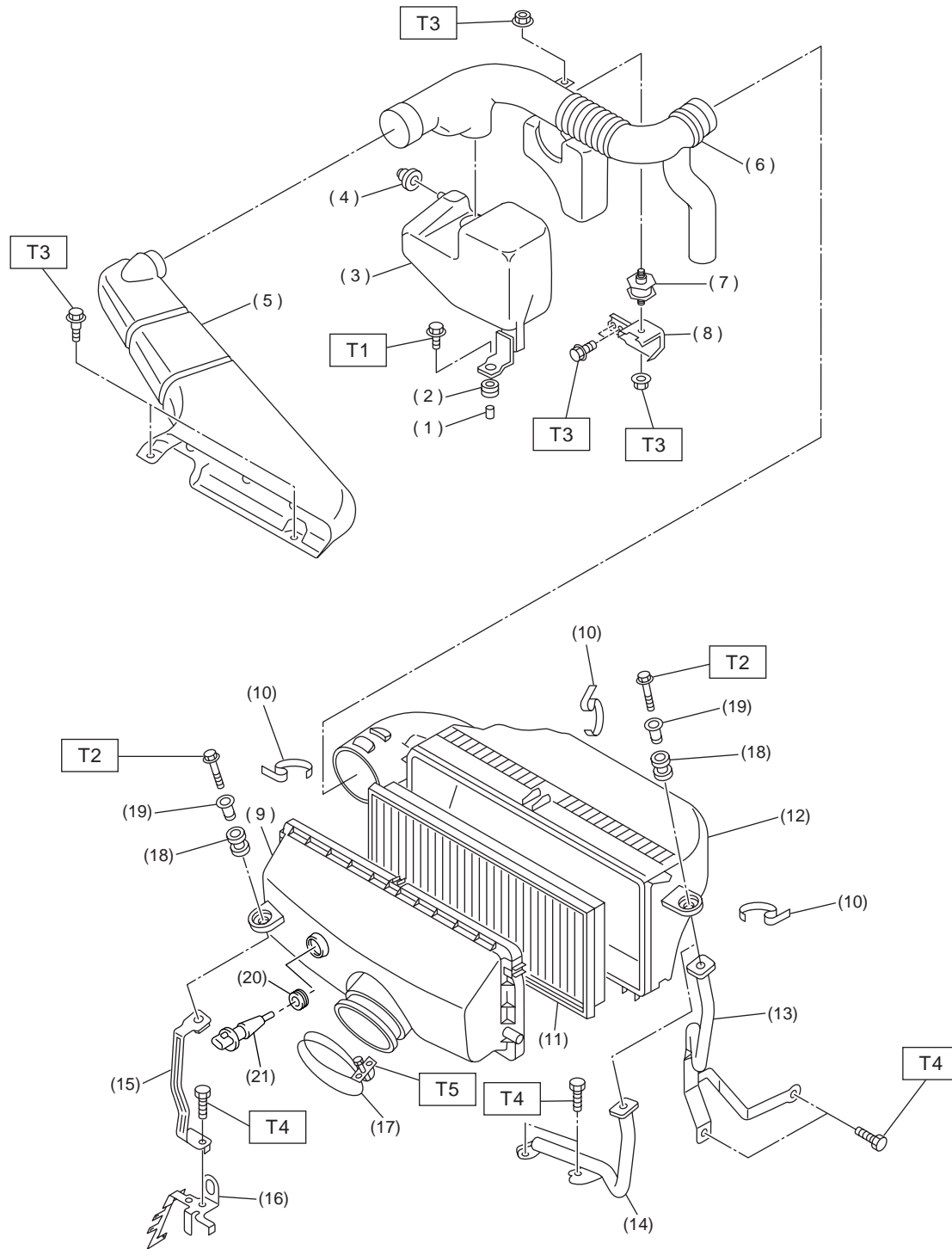

IN-00057

IN(H4SO)-2

GENERAL DESCRIPTION

INTAKE (INDUCTION)

(1) Spacer	(11) Air cleaner element	(19) Spacer
(2) Bushing	(12) Air cleaner case B	(20) Grommet
(3) Resonator chamber	(13) Air cleaner case stay LH (MT vehicles)	(21) Intake air temperature sensor
(4) Cushion rubber		
(5) Air intake duct A	(14) Air cleaner case stay LH (AT vehicles)	Tightening torque: N·m (kgf-m, ft-lb)
(6) Air intake duct B		T1: 33 (3.4, 24.6)
(7) Cushion	(15) Air cleaner case stay RH	T2: 6.5 (0.66, 4.8)
(8) Bracket	(16) Engine harness bracket	T3: 7.5 (0.76, 5.5)
(9) Air cleaner case A	(17) Clamp	T4: 16 (1.6, 11.6)
(10) Clip	(18) Bushing	T5: 3 (0.3, 2.2)

B: CAUTION

- Wear working clothing, including a cap, protective goggles, and protective shoes during operation.
- Remove contamination including dirt and corrosion before removal, installation or disassembly.
- Keep the disassembled parts in order and protect them from dust or dirt.
- Before removal, installation or disassembly, be sure to clarify the failure. Avoid unnecessary removal, installation, disassembly, and replacement.
- Be careful not to burn your hands, because each part on the vehicle is hot after running.
- Be sure to tighten fasteners including bolts and nuts to the specified torque.
- Place shop jacks or safety stands at the specified points.
- Before disconnecting electrical connectors of sensor or units, be sure to disconnect ground cable from battery.