

VALVE CLEARANCE

MECHANICAL

8. Valve Clearance

A: INSPECTION

CAUTION:

Inspection and adjustment of valve clearance should be performed while engine is cold.

- 1) Set the vehicle onto the lift.
- 2) Lift-up the vehicle.
- 3) Remove under cover.

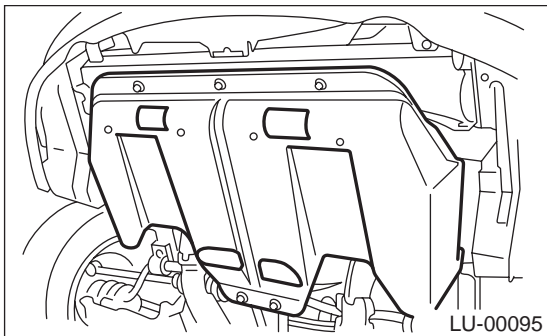

- 4) Lower the vehicle.
- 5) Disconnect battery ground cable.

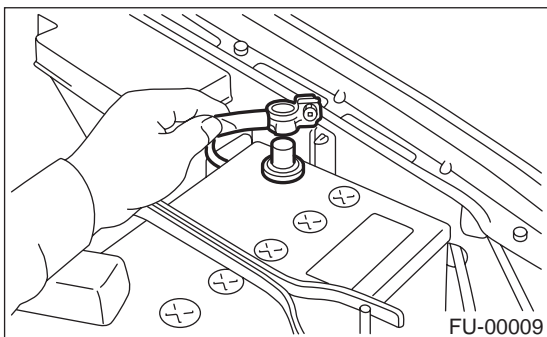

- 6) Remove timing belt cover (LH).

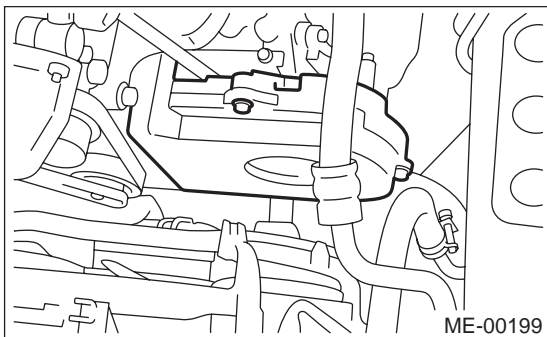

- 7) When inspecting #1 and #3 cylinders;

- (1) Remove air intake duct as a unit.

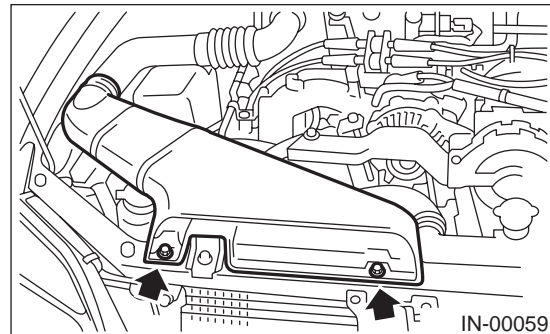

- (2) Remove bolt, and then remove resonator chamber.

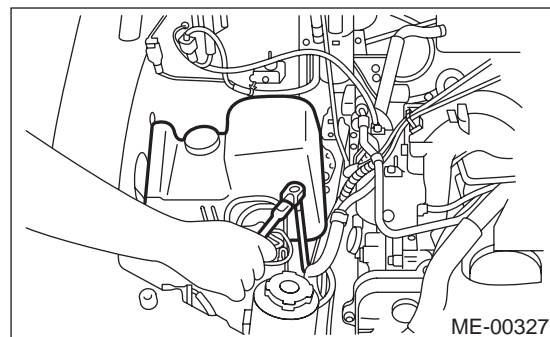

- (3) Disconnect spark plug cords from spark plugs (#1 and #3 cylinders).

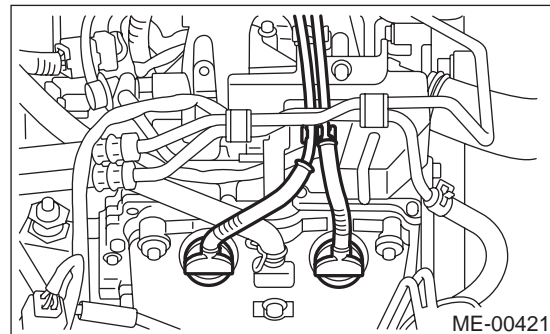

- (4) Disconnect PCV hose from rocker cover (RH).
- (5) Remove bolts, then remove rocker cover (RH).

VALVE CLEARANCE

MECHANICAL

- 8) When inspecting #2 and #4 cylinders;
(1) Disconnect battery cables, and then remove battery and battery carrier.

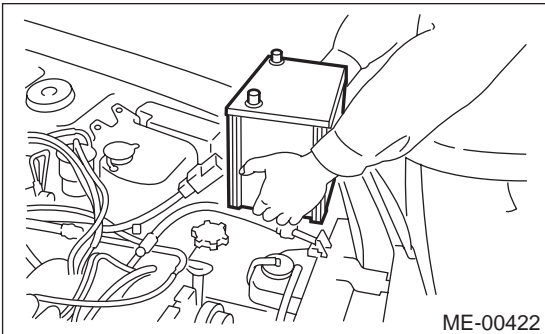

- (2) Remove the two bolts which hold washer tank.

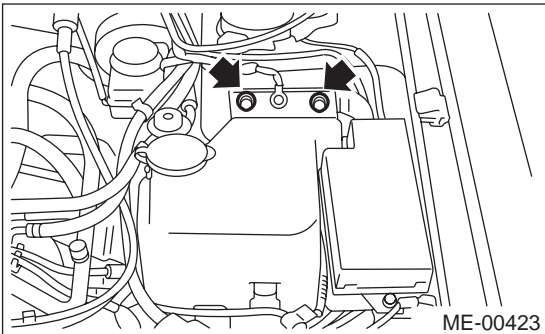

- (3) Disconnect washer motor connectors.

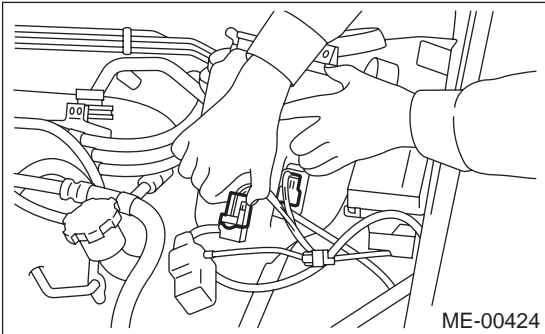

- (4) Move washer tank to forward.

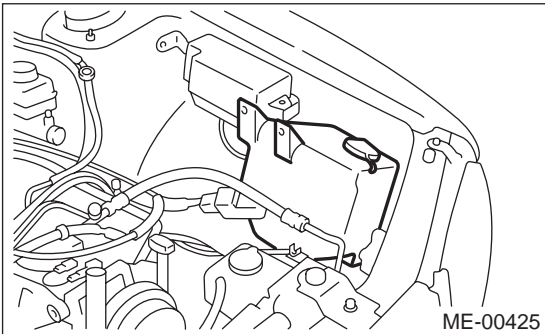

- (5) Disconnect spark plug cords from spark plugs (#2 and #4 cylinders).
(6) Disconnect PCV hose from rocker cover (LH).
(7) Remove bolts, then remove rocker cover (LH).

- 9) Set #1 cylinder piston to top dead center of compression stroke by rotating crankshaft pulley clockwise.

NOTE:

When arrow mark (A) on camshaft sprocket (LH) comes exactly to the top, #1 cylinder piston is brought to the top dead center of compression stroke.

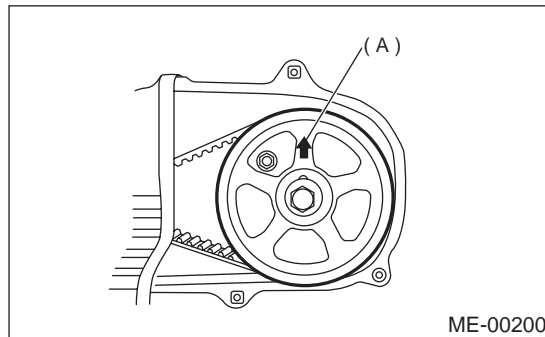

- 10) Measure #1 cylinder valve clearance by using thickness gauge.

NOTE:

- Insert the thickness gauge in as horizontal a direction as possible with respect to the valve stem end face.
- Measure exhaust valve clearances while lifting-up the vehicle.

Valve clearance:

Intake;

$0.20 \pm 0.02 \text{ mm (0.0079} \pm 0.0008 \text{ in)}$

Exhaust;

$0.25 \pm 0.02 \text{ mm (0.0098} \pm 0.0008 \text{ in)}$

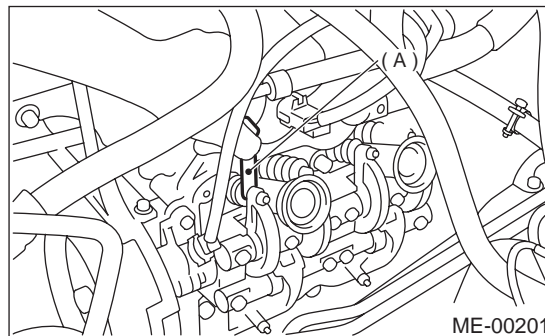

(A) Thickness gauge

VALVE CLEARANCE

MECHANICAL

11) If necessary, adjust the valve clearance. <Ref. to ME(H4SO)-31, ADJUSTMENT, Valve Clearance.>

12) Similar to measurement procedures used for #1 cylinder, measure #2, #3 and #4 cylinder valve clearances.

NOTE:

- Be sure to set cylinder pistons to their respective top dead centers on compression stroke before measuring valve clearances.
- To set #3, #2 and #4 cylinder pistons to their top dead centers on compression stroke, turn crankshaft pulley clockwise 90° at a time starting with arrow mark on left-hand camshaft sprocket facing up.

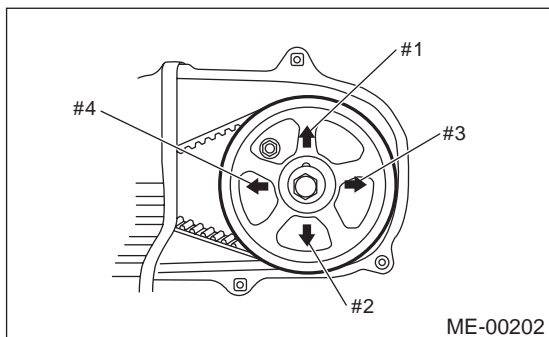

13) After inspection, install the related parts in the reverse order of removal.

Tightening torque:

**Resonator chamber;
32 N·m (3.3 kgf·m, 24 ft·lb)**

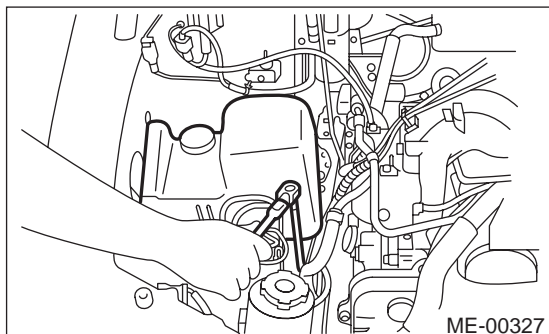

B: ADJUSTMENT

NOTE:

Adjustment of valve clearance should be performed while engine is cold.

1) Set #1 cylinder piston to top dead center of compression stroke by rotating crankshaft pulley clockwise.

NOTE:

When arrow mark (A) on camshaft sprocket (LH) comes exactly to the top, #1 cylinder piston is brought to the top dead center of compression stroke.

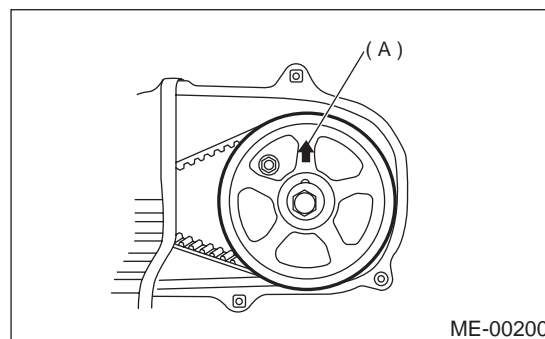

2) Adjust the #1 cylinder valve clearance.

- (1) Loosen the valve rocker nut and screw.
- (2) Place suitable thickness gauge.
- (3) While noting valve clearance, tighten valve rocker adjust screw.
- (4) When specified valve clearance is obtained, tighten valve rocker nut.

Tightening torque:

10 N·m (1.0 kgf·m, 7.2 ft·lb)

NOTE:

- Insert the thickness gauge in as horizontal a direction as possible with respect to the valve stem end face.
- Adjust exhaust valve clearances while lifting-up the vehicle.

VALVE CLEARANCE

MECHANICAL

Valve clearance:

Intake;

$0.20 \pm 0.02 \text{ mm}$ ($0.0079 \pm 0.0008 \text{ in}$)

Exhaust;

$0.25 \pm 0.02 \text{ mm}$ ($0.0098 \pm 0.0008 \text{ in}$)

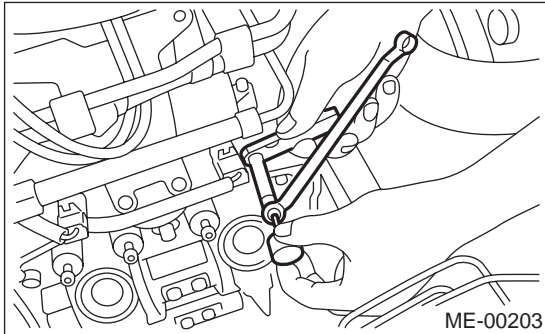

- 3) Ensure that valve clearances are within specifications.
- 4) Turn crankshaft two complete rotations until #1 cylinder piston is again set to top dead center on compression stroke.
- 5) Ensure that valve clearances are within specifications. If necessary, readjust valve clearances.
- 6) Similar to adjustment procedures used for #1 cylinder, adjust #2, #3 and #4 cylinder valve clearances.

NOTE:

- Be sure to set cylinder pistons to their respective top dead centers on compression stroke before adjusting valve clearances.
- To set #3, #2 and #4 cylinder pistons to their top dead centers on compression stroke, turn crankshaft pulley clockwise 90° at a time starting with arrow mark on left-hand camshaft sprocket facing up.

