

CRANKSHAFT PULLEY

MECHANICAL

13. Crankshaft Pulley

A: REMOVAL

1) Remove V-belt. <Ref. to ME(H4SO)-42, REMOVAL, V-belt.>

2) Remove crankshaft pulley bolt. To lock crankshaft, use ST.

ST 499977100

CRANKSHAFT PULLEY WRENCH

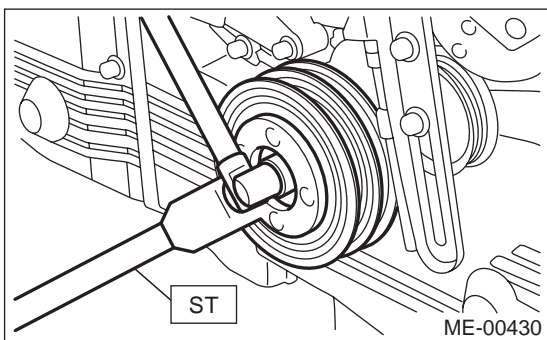

3) Remove crankshaft pulley.

B: INSTALLATION

1) Install crankshaft pulley.

2) Install pulley bolt.

To lock crankshaft, use ST.

ST 499977100 CRANKSHAFT PULLEY WRENCH

(1) Clean the crankshaft pulley thread using an air gun.

(2) Apply engine oil to the crankshaft pulley bolt seat and thread.

(3) Tighten the bolts temporarily with tightening torque of 44 N·m (4.5 kgf·m, 33 ft·lb).

(4) Tighten the crankshaft pulley bolts.

Tightening torque:

177 N·m (18.0 kgf·m, 130.2 ft·lb)

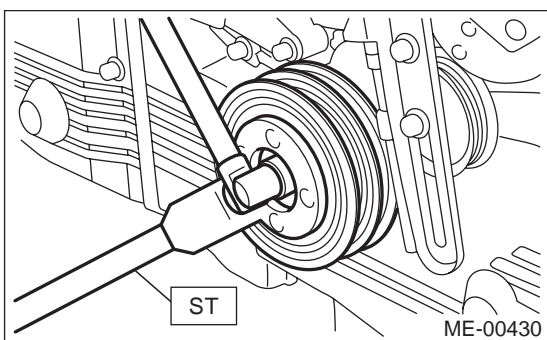

3) Confirm that the tightening angle of the crankshaft pulley bolt is 65 degrees or more. If not, conduct the following procedures (1) through (4).

(1) Replace the crankshaft pulley bolts and clean them.

Crankshaft pulley bolt:

12369AA011

(2) Clean the crankshaft thread using an air gun.

(3) Apply engine oil to the crankshaft pulley bolt seat and thread.

(4) Tighten the bolts temporarily with tightening torque of 44 N·m (4.5 kgf·m, 33 ft·lb).

(5) Tighten the crankshaft pulley bolts keeping them in an angle between 65 degrees and 75 degrees.

NOTE:

Conduct the tightening procedures by confirming the turning angle of the crankshaft pulley bolt referring to the gauge indicated on the belt cover.

4) Install A/C belt tensioner.

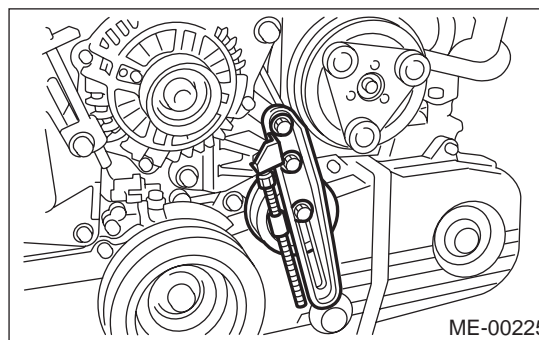

5) Install A/C belt.

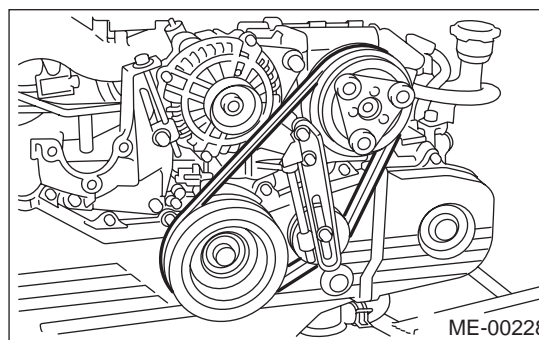

C: INSPECTION

1) Make sure the V-belt is not worn or otherwise damaged.

2) Check the tension of the belt. <Ref. to ME(H4SO)-43, INSPECTION, V-belt.>