

RADIATOR

COOLING

7. Radiator

A: REMOVAL

1) Disconnect battery ground cable.

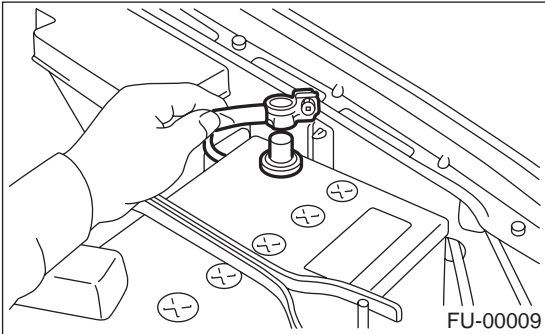

2) Lift-up the vehicle.

3) Remove under cover.

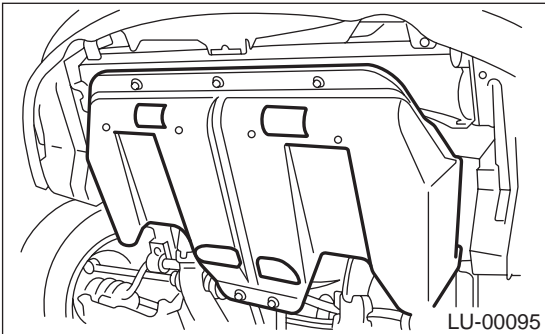

4) Drain engine coolant completely. <Ref. to CO(H6DO)-22, DRAINING OF ENGINE COOLANT, REPLACEMENT, Engine Coolant.>

5) Disconnect connectors of radiator main fan motor (A) and sub fan motor (B).

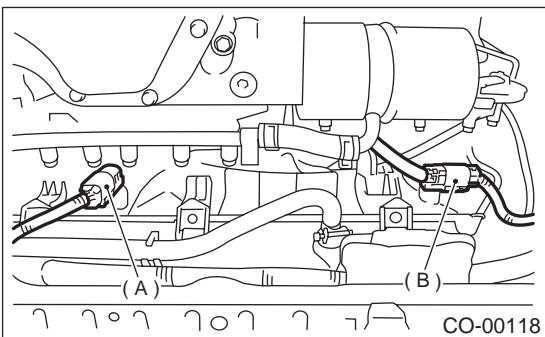

6) Disconnect radiator outlet hose from radiator.

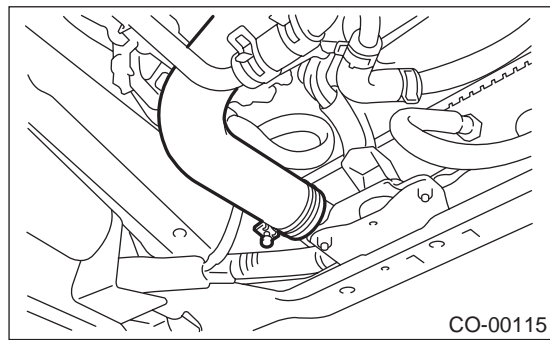

7) Disconnect ATF cooler hoses from radiator.

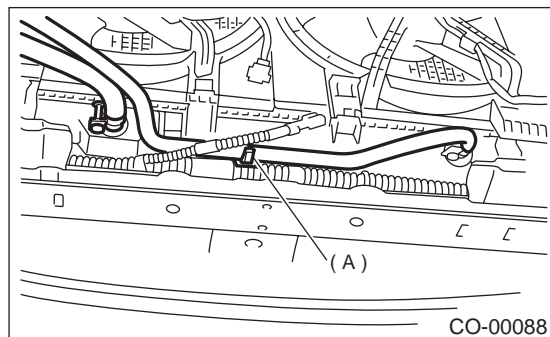

(A) Clip

8) Lower the vehicle.

9) Remove air intake duct.

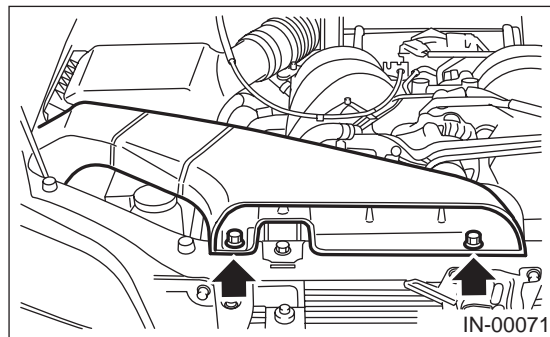

10) Disconnect over flow hose.

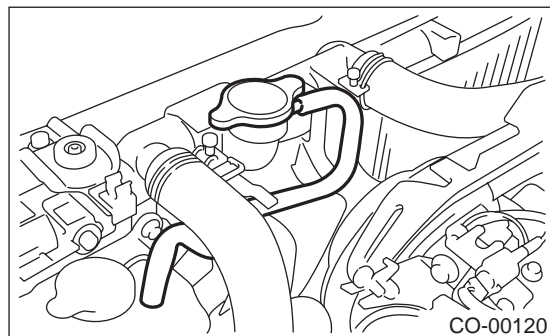

RADIATOR

COOLING

11) Remove reservoir tank.

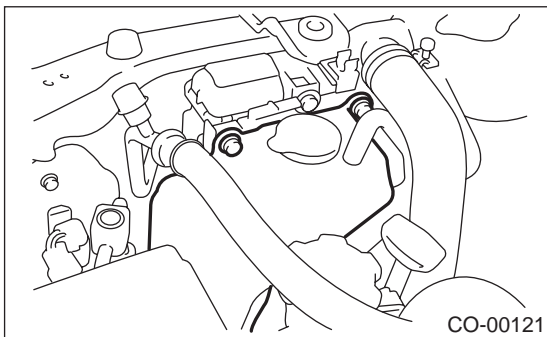

12) Disconnect radiator inlet hoses from radiator.

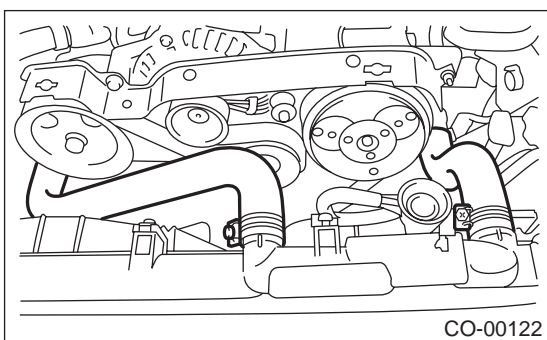

13) Remove radiator upper brackets.

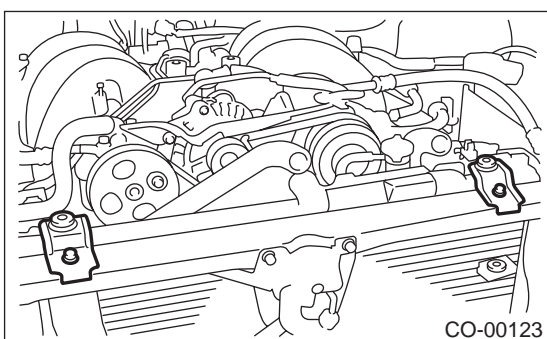

14) Detach power steering hose from the clip on the radiator.

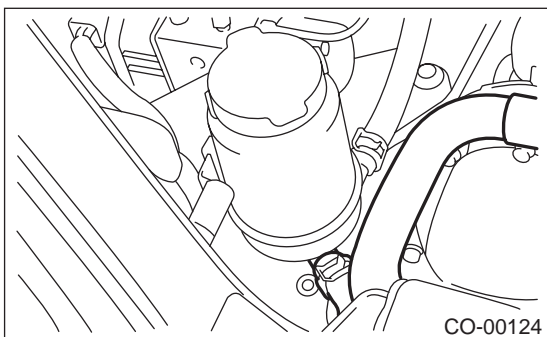

15) While slightly lifting radiator, slide it to left.

16) Lift radiator up and away from vehicle.

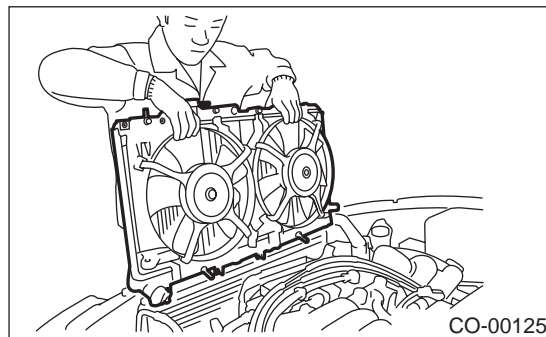

B: INSTALLATION

1) Attach radiator mounting cushions to holes on the vehicle.

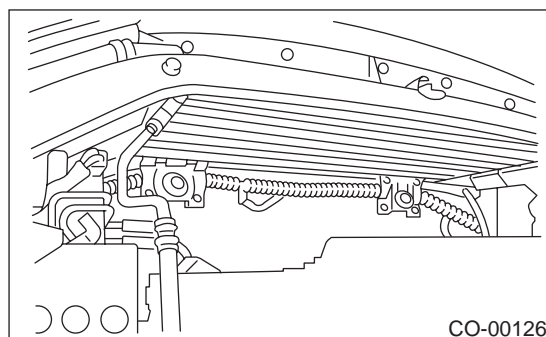

2) Install radiator while fitting radiator pins to cushions.

NOTE:

Fit pins on lower side of radiator into cushions on body side.

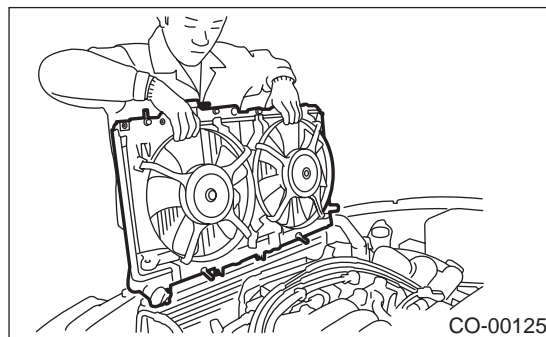

RADIATOR

COOLING

3) Install radiator brackets and tighten bolts.

Tightening torque:
12 N·m (1.2 kgf·m, 8.7 ft·lb)

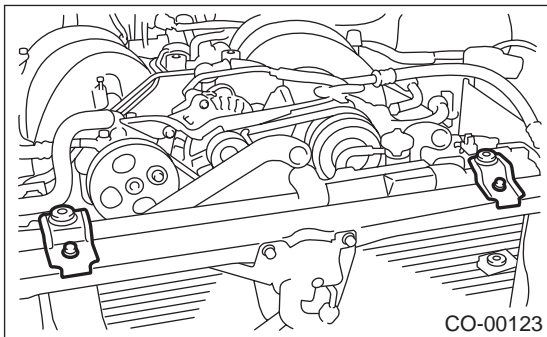

4) Attach power steering hose to the radiator.

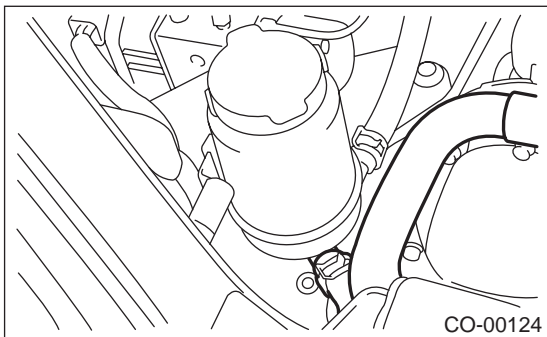

5) Connect radiator inlet hoses.

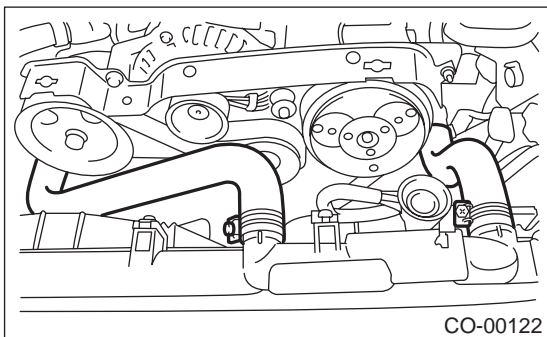

6) Install reservoir tank.

Tightening torque:
4.9 N·m (0.50 kgf·m, 3.6 ft·lb)

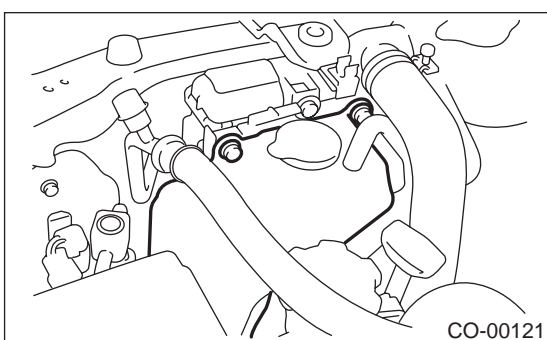

7) Install air intake duct.

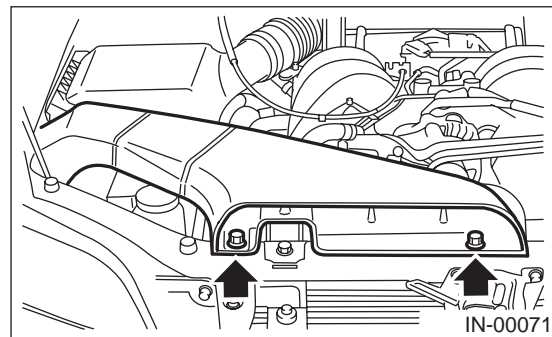

8) Lift-up the vehicle.

9) Connect ATF cooler hoses.

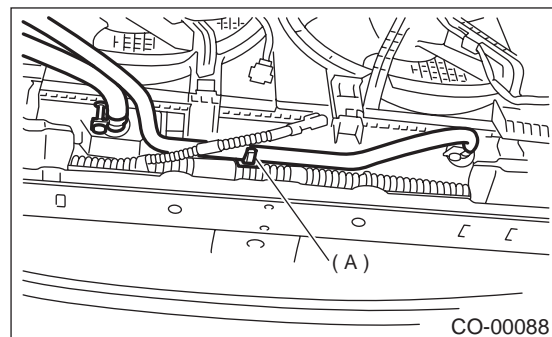

(A) Clip

10) Connect connectors to radiator main fan motor (A) and sub fan motor (B).

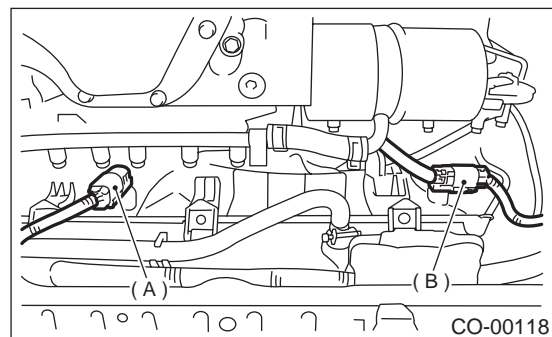

11) Connect radiator outlet hose.

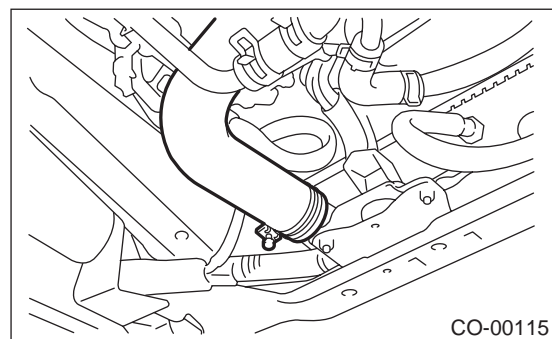

RADIATOR

COOLING

12) Install under cover.

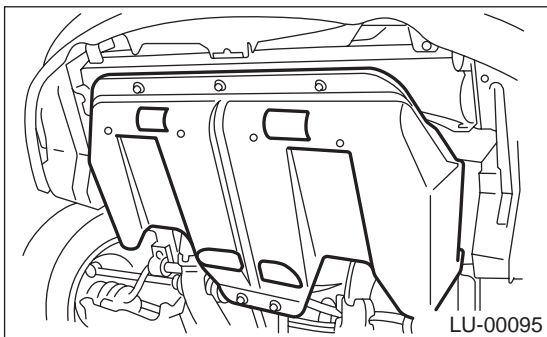

13) Lower the vehicle.

14) Connect battery ground cable.

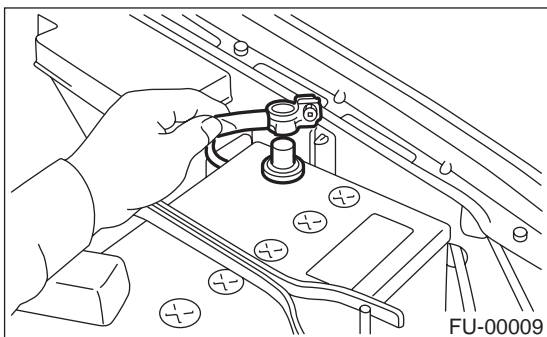

15) Fill coolant. <Ref. to CO(H6DO)-22, FILLING OF ENGINE COOLANT, REPLACEMENT, Engine Coolant.>

16) Check ATF level. <Ref. to AT-30, INSPECTION, Automatic Transmission Fluid.>

C: INSPECTION

1) Remove radiator cap, top off radiator, and attach tester to radiator in place of cap.

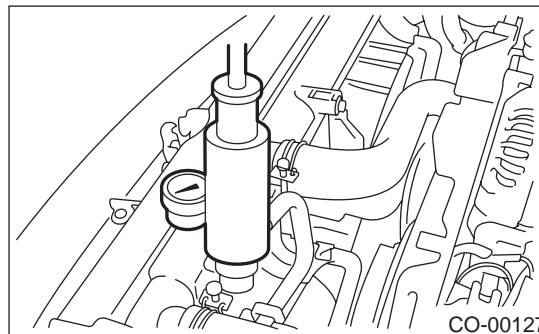

2) Apply a pressure of 157 kPa (1.6 kg/cm², 23 psi) to radiator to check if:

- (1) Engine coolant leaks at/around radiator.
- (2) Engine coolant leaks at/around hoses or connections.

CAUTION:

- Engine should be off.
- Wipe engine coolant from check points in advance.
- Be careful to prevent engine coolant from spurting out when removing tester.
- Be careful also not to deform filler neck of radiator when installing or removing tester.