

INSPECTION MODE

ENGINE (DIAGNOSTICS)

12. Inspection Mode

A: OPERATION

Carry out trouble diagnosis shown in the following DTC table.

When performing trouble diagnosis which is not shown in the DTC table, refer to the next item Drive cycle.

<Ref. to EN(H6DO)-57, Drive Cycle.>

DTC No.	Item
P0030	HO2S Heater control circuit (Bank 1 Sensor 1)
P0031	HO2S Heater control circuit low (Bank 1 Sensor 1)
P0032	HO2S Heater control circuit high (Bank 1 Sensor 1)
P0037	HO2S Heater control circuit low (Bank 1 Sensor 2)
P0038	HO2S Heater control circuit high (Bank 1 Sensor 2)
P0050	HO2S Heater control circuit (Bank 2 Sensor 1)
P0051	HO2S Heater control circuit low (Bank 2 Sensor 1)
P0052	HO2S Heater control circuit high (Bank 2 Sensor 1)
P0068	Manifold absolute pressure/barometric pressure circuit range/performance
P0107	Manifold absolute pressure/barometric pressure circuit low input
P0108	Manifold absolute pressure/barometric pressure circuit high input
P0112	Intake air temperature circuit low input
P0113	Intake air temperature circuit high input
P0117	Engine coolant temperature circuit low input
P0118	Engine coolant temperature circuit high input
P0122	Throttle/pedal position sensor/switch "A" circuit low input
P0123	Throttle/pedal position sensor/switch "A" circuit high input
P0129	Barometric pressure too low
P0130	O2 sensor circuit (Bank 1 Sensor 1)
P0134	O2 sensor circuit no activity detected (Bank 1 Sensor 1)
P0137	O2 sensor circuit low voltage (Bank 1 Sensor 2)
P0138	O2 sensor circuit high voltage (Bank 1 Sensor 2)
P0150	O2 sensor circuit (Bank 2 Sensor 1)
P0154	O2 sensor circuit no activity detected (Bank 2 Sensor 1)
P0182	Fuel temperature sensor "A" circuit low input
P0183	Fuel temperature sensor "A" circuit high input
P0230	Fuel pump primary circuit
P0327	Knock sensor 1 circuit low input (Bank 1 or Single sensor)
P0328	Knock sensor 1 circuit high input (Bank 1 or Single sensor)
P0332	Knock sensor 2 circuit low input (Bank 2)
P0333	Knock sensor 2 circuit high input (Bank 2)
P0335	Crankshaft position sensor "A" circuit
P0336	Crankshaft position sensor "A" circuit range/performance
P0340	Camshaft position sensor "A" circuit (Bank 1 or Single Sensor)
P0341	Camshaft position sensor "A" circuit range/performance (Bank 1 or Single Sensor)
P0447	Evaporative emission control system vent control circuit open
P0448	Evaporative emission control system vent control circuit shorted
P0452	Evaporative emission control system pressure sensor low input
P0458	Evaporative emission control system purge control valve circuit low
P0462	Fuel level sensor circuit low input
P0463	Fuel level sensor circuit high input
P0502	Vehicle speed sensor circuit low input
P0503	Vehicle speed sensor intermittent/erratic/high
P0508	Idle control system circuit low
P0509	Idle control system circuit high

INSPECTION MODE

ENGINE (DIAGNOSTICS)

DTC No.	Item
P0512	Starter request circuit
P0519	Idle air control circuit system performance
P0558	Alternator circuit low input
P0559	Alternator circuit high input
P0565	Cruise control on signal
P0604	Internal control module random access memory (RAM) error
P0661	Intake manifold tuning valve control circuit low - bank 1
P0662	Intake manifold tuning valve control circuit high - bank 2
P0691	Cooling fan 1 control circuit low
P0692	Cooling fan 1 control circuit high
P0703	Torque converter/brake switch "B" circuit
P0705	Transmission range sensor circuit (PRNDL input)
P0710	Transmission fluid temperature sensor circuit
P0716	Input/turbine speed sensor circuit range/performance
P0720	Output speed sensor circuit
P0726	Engine speed input circuit range/performance
P0731	Gear 1 incorrect ratio
P0732	Gear 2 incorrect ratio
P0733	Gear 3 incorrect ratio
P0734	Gear 4 incorrect ratio
P0741	Torque converter clutch circuit performance or stuck off
P0743	Torque converter clutch circuit electrical
P0748	Pressure control solenoid "A" electrical
P0753	Shift solenoid "A" electrical
P0758	Shift solenoid "B" electrical
P0771	Shift solenoid "E" performance or stuck off
P0778	Pressure control solenoid "B" electrical
P0785	Shift/timing solenoid
P0851	Neutral switch input circuit low
P0852	Neutral switch input circuit high
P0864	TCM communication circuit range/performance
P0865	TCM communication circuit low
P0866	TCM communication circuit high
P1110	Atmospheric pressure sensor circuit malfunction (low input)
P1111	Atmospheric pressure sensor circuit malfunction (high input)
P1134	A/F sensor micro-computer problem
P1152	O2 sensor circuit range/performance (low) (Bank 1 Sensor 1)
P1153	O2 sensor circuit range/performance (high) (Bank 1 Sensor 2)
P1154	O2 sensor circuit range/performance (low) (Bank 2 Sensor 1)
P1155	O2 sensor circuit range/performance (high) (Bank 2 Sensor 1)
P1400	Fuel tank pressure control solenoid valve circuit low
P1420	Fuel tank pressure control solenoid valve circuit high
P1443	Vent control solenoid valve function problem
P1446	Fuel tank sensor control valve circuit low
P1447	Fuel tank sensor control valve circuit high
P1518	Starter switch circuit low input
P1560	Back-up voltage circuit malfunction
P1698	Engine torque control cut signal circuit malfunction (low input)
P1699	Engine torque control cut signal circuit malfunction (high input)
P1700	Throttle position sensor circuit malfunction for AT

INSPECTION MODE

ENGINE (DIAGNOSTICS)

DTC No.	Item
P1711	Engine torque control signal #1 circuit malfunction
P1712	Engine torque control signal #2 circuit malfunction

INSPECTION MODE

ENGINE (DIAGNOSTICS)

1. PREPARATION FOR THE INSPECTION MODE

- 1) Make sure that fuel remains approx. half amount [20 to 40 ℓ (5.3 — 10.6 US gal, 4.4 — 8.8 Imp gal)], and battery voltage is 12V or more.
- 2) Raise the vehicle using a garage jack and place on safety stands or drive the vehicle onto free rollers.

WARNING:

- Before raising the vehicle, ensure parking brakes are applied.
- Do not use a pantograph jack in place of a safety stand.
- Secure a rope or wire to the front and rear towing or tie-down hooks to prevent the lateral runout of front wheels.
- Do not abruptly depress/release clutch pedal or accelerator pedal during works even when engine is operating at low speeds since this may cause vehicle to jump off free rollers.
- In order to prevent the vehicle from slipping due to vibration, do not place any wooden blocks or similar items between the safety stands and the vehicle.
- Since the rear wheels will also rotate, do not place anything near them. Also, make sure that nobody goes in front of the vehicle.

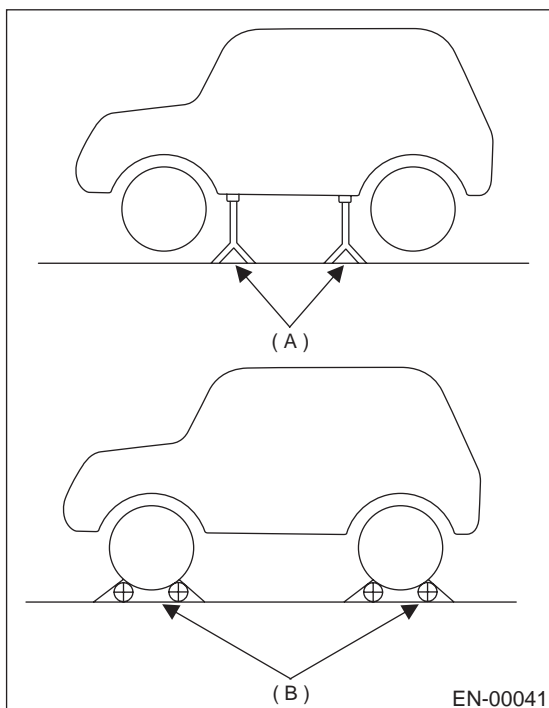

(A) Safety stand

(B) Free rollers

- 3) Warm up engine.

2. SUBARU SELECT MONITOR

- 1) After performing diagnostics and clearing the memory, check for any remaining unresolved trouble data. <Ref. to EN(H6DO)-59, Clear Memory Mode.>
- 2) Prepare Subaru Select Monitor kit. <Ref. to EN(H6DO)-9, PREPARATION TOOL, General Description.>



- 3) Connect diagnosis cable to Subaru Select Monitor.
- 4) Insert cartridge into Subaru Select Monitor. <Ref. to EN(H6DO)-9, PREPARATION TOOL, General Description.>

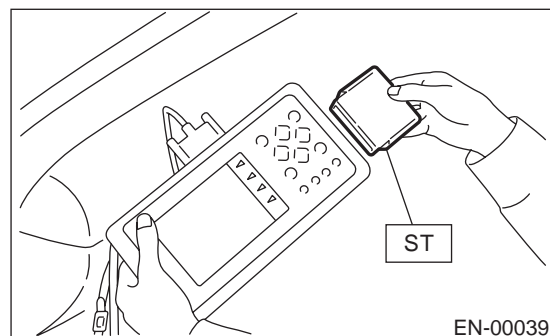

- 5) Connect test mode connector at the lower portion of instrument panel (on the driver's side).

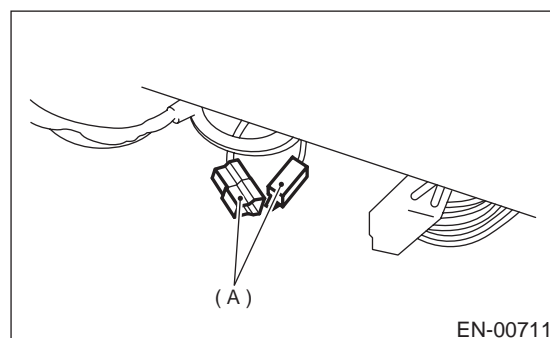

(A) Test mode connector

INSPECTION MODE

ENGINE (DIAGNOSTICS)

6) Connect Subaru Select Monitor to data link connector.

(1) Connect Subaru Select Monitor to data link connector (A) located in the lower portion of the instrument panel (on the driver's side).

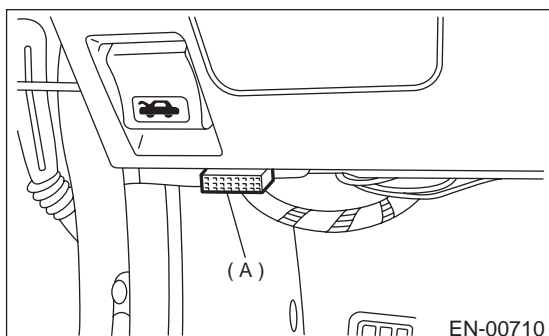

(A) Data link connector

(2) Connect diagnosis cable to data link connector.

CAUTION:

Do not connect scan tools except for Subaru Select Monitor and OBD-II general scan tool.

7) Turn ignition switch to ON (engine OFF) and Subaru Select Monitor switch to ON.

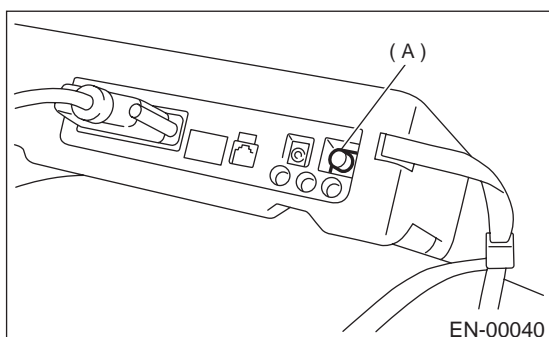

(A) Power switch

8) On the «Main Menu» display screen, select the {2. Each System Check} and press the [YES] key.

9) On the «System Selection Menu» display screen, select the {Engine Control System} and press the [YES] key.

10) Press the [YES] key after displayed the information of engine type.

11) On the «Engine Diagnosis» display screen, select the {Dealer Check Mode Procedure} and press the [YES] key.

12) When the "Perform Inspection (Dealer Check Mode?)" is shown on the display screen, press the [YES] key.

13) Perform subsequent procedures as instructed on the display screen.

• If trouble still remains in the memory, the corresponding diagnostic trouble code (DTC) appears on the display screen.

NOTE:

• For detailed operation procedure, refer to the SUBARU SELECT MONITOR OPERATION MANUAL.

• For detailed concerning diagnostic trouble codes, refer to the List of Diagnostic Trouble Code (DTC).

<Ref. to EN(H6DO)-93, List of Diagnostic Trouble Code (DTC).>

• Release the parking brake.

• The speed difference between front and rear wheels may light either the ABS warning light, but this indicates no malfunctions. When engine control diagnosis is finished, perform the ABS memory clearance procedure of self-diagnosis system.

3. OBD-II GENERAL SCAN TOOL

1) After performing diagnostics and clearing the memory, check for any remaining unresolved trouble data: <Ref. to EN(H6DO)-59, Clear Memory Mode.>

2) Connect test mode connector at the lower side of the instrument panel (on the driver's side).

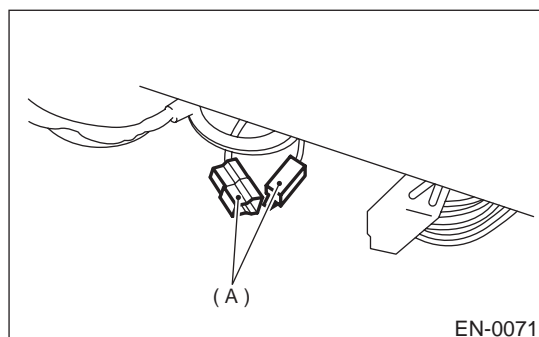

(A) Test mode connector

INSPECTION MODE

ENGINE (DIAGNOSTICS)

3) Connect the OBD-II general scan tool to its data link connector in the lower portion of the instrument panel (on the driver's side).

CAUTION:

Do not connect the scan tools except for Subaru Select Monitor and OBD-II general scan tool.

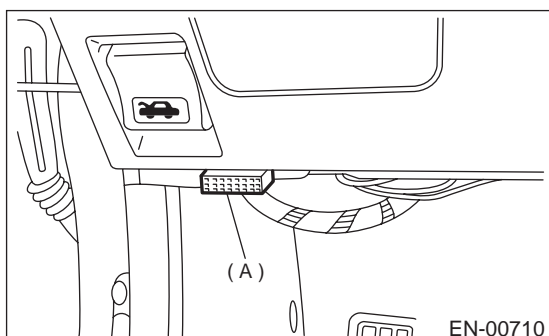

(A) Data link connector

4) Start the engine.

NOTE:

Ensure the selector lever is placed in the "P" position before starting.

5) Using the selector lever or shift lever, turn the "P" position switch and the "N" position switch to ON.

6) Depress the brake pedal to turn the brake switch ON.

7) Keep engine speed in the 2,500 — 3,000 rpm range for 40 seconds.

8) Place the selector lever or shift lever in the "D" position and drive the vehicle at 5 to 10 km/h (3 to 6 MPH).

NOTE:

- On AWD vehicles, release the parking brake.
- The speed difference between front and rear wheels may light the ABS warning light, but this indicates no malfunctions. When engine control diagnosis is finished, perform the ABS memory clearance procedure of self-diagnosis system.

9) Using the OBD-II general scan tool, check for diagnostic trouble code(s) and record the result(s).

NOTE:

- For detailed operation procedures, refer to the OBD-II General Scan Tool Instruction Manual.
- For detailed concerning diagnostic trouble codes, refer to the List of Diagnostic Trouble Code (DTC).

<Ref. to EN(H6DO)-93, List of Diagnostic Trouble Code (DTC).>