

FUEL DELIVERY, RETURN AND EVAPORATION LINES

FUEL INJECTION (FUEL SYSTEMS)

30. Fuel Delivery, Return and Evaporation Lines

A: REMOVAL

- 1) Set vehicle on the lift.
- 2) Release fuel pressure. <Ref. to FU(H6DO)-50, RELEASING OF FUEL PRESSURE, OPERATION, Fuel.>
- 3) Open fuel filler flap lid and remove fuel filler cap.
- 4) Remove fuel tank. <Ref. to FU(H6DO)-53, REMOVAL, Fuel Tank.>
- 5) Remove fuel filler pipe. <Ref. to FU(H6DO)-61, REMOVAL, Fuel Filler Pipe.>
- 6) Remove floor mat. <Ref. to EI-50, REMOVAL, Floor Mat.>
- 7) Remove fuel delivery pipes and hoses, fuel return pipes and hoses, evaporation pipes and hoses.

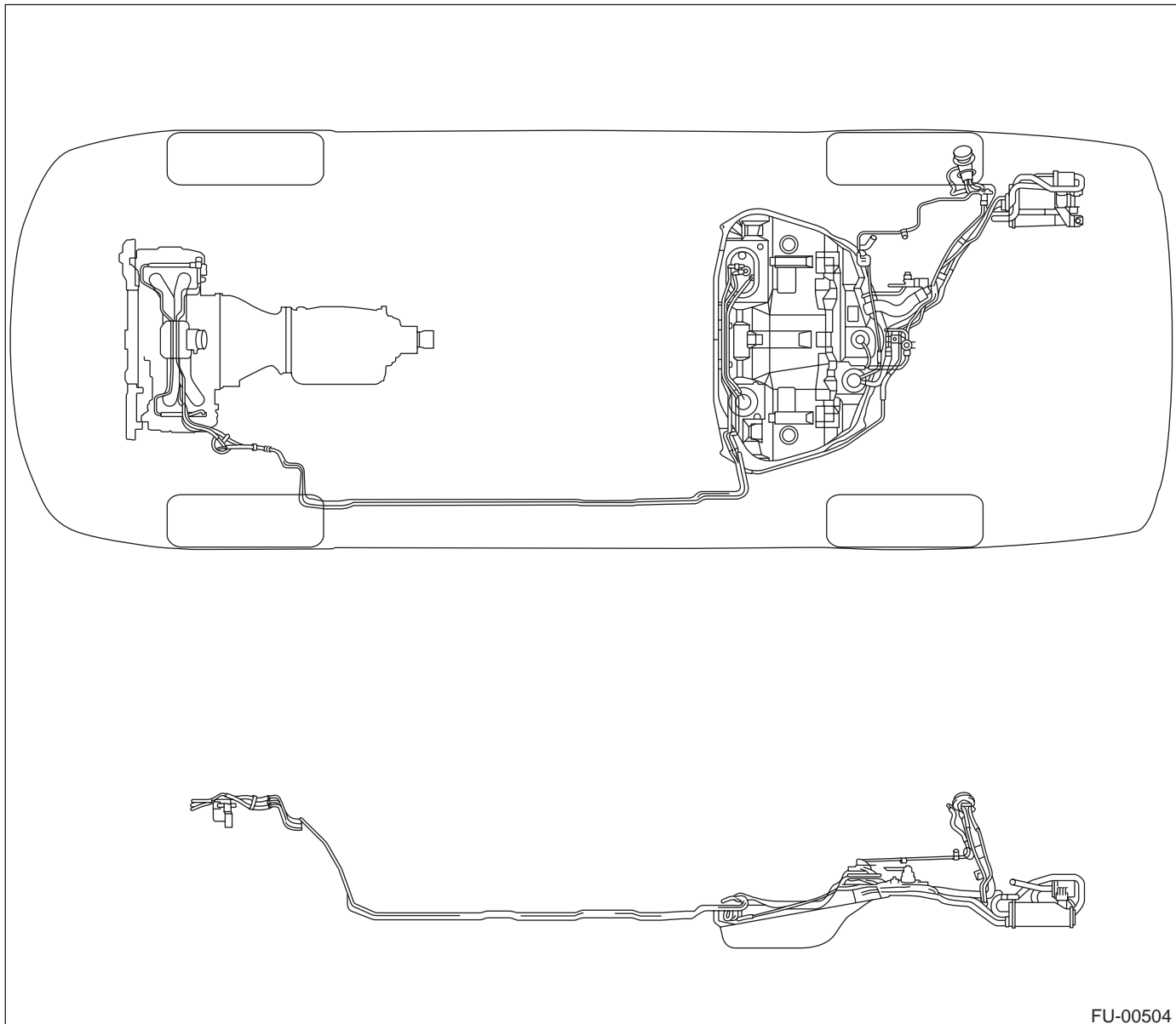

FU-00504

FU(H6DO)-78

FUEL DELIVERY, RETURN AND EVAPORATION LINES

FUEL INJECTION (FUEL SYSTEMS)

8) In engine compartment, detach fuel delivery hoses, return hoses and evaporation hose.

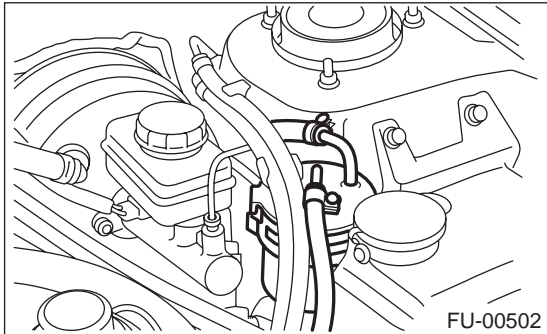

9) Separate quick connector on fuel delivery and return line.

- (1) Clean pipe and connector, if they are covered with dust.
- (2) Hold connector (A) and push retainer (B) down.
- (3) Pull out connector (A) from retainer (B).

CAUTION:

Replace retainer with new ones.

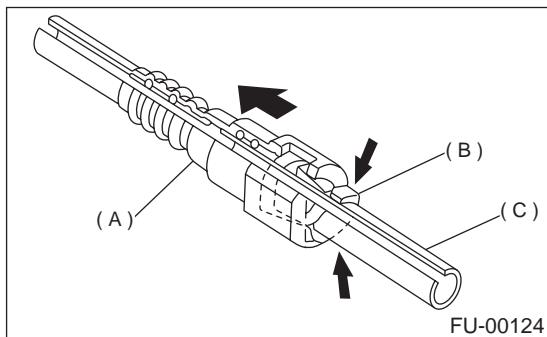

- (A) Connector
- (B) Retainer
- (C) Pipe

B: INSTALLATION

1) Connect quick connector on fuel delivery and return line.

CAUTION:

- Always use a new retainer.
- Make sure that the connected portion is not damaged or has dust. If necessary, clean seal surface (A) of pipe (B).

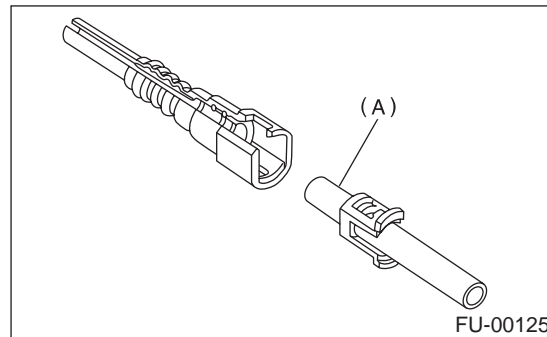

- (1) Set new retainer (B) to connector (A).
- (2) Push pipe into connector completely.

NOTE:

At this time, two clicking sounds are heard.

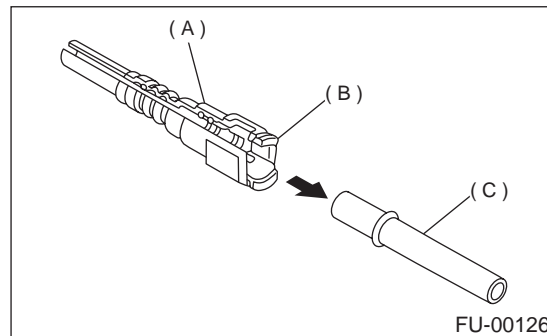

- (A) Connector
- (B) Retainer
- (C) Pipe

CAUTION:

- Pull the connector to ensure it is connected securely.
- Ensure the two retainer pawls are engaged in their mating positions in the connector.

FUEL DELIVERY, RETURN AND EVAPORATION LINES

FUEL INJECTION (FUEL SYSTEMS)

- Be sure to inspect hoses and their connections for any leakage of fuel.

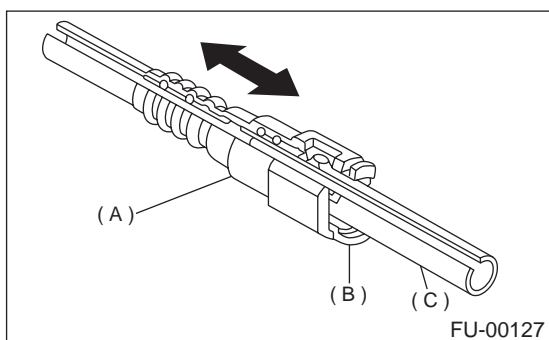

- (A) Connector
- (B) Retainer
- (C) Pipe

2) Connect fuel delivery hose to pipe with an overlap of 20 to 25 mm (0.79 to 0.98 in).

Type A: When fitting length is specified.

Type B: When fitting length is not specified.

$\varnothing : 2.5 \pm 1.5 \text{ mm } (0.098 \pm 0.059 \text{ in})$

$L: 22.5 \pm 2.5 \text{ mm } (0.886 \pm 0.098 \text{ in})$

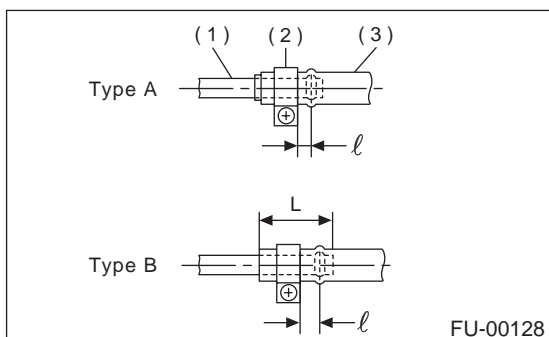

- (1) Fitting
- (2) Clamp
- (3) Hose

3) Connect evaporation hose to pipe by approx. 15 mm (0.59 in) from hose end.

$L = 17.5 \pm 2.5 \text{ mm } (0.689 \pm 0.098 \text{ in})$

CAUTION:

Be sure to inspect hoses and their connections for any leakage of fuel.

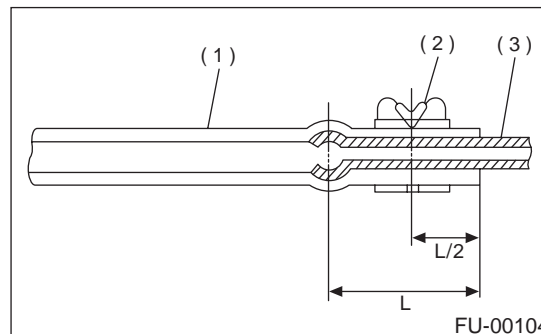

- (1) Hose
- (2) Clip
- (3) Pipe

C: INSPECTION

1) Make sure that there are no cracks on the fuel pipes and fuel hoses.

2) Make sure that the fuel pipe and fuel hose connections are tight.