

GENERAL DESCRIPTION

IGNITION

1. General Description

A: SPECIFICATIONS

Item		Designation
Ignition coil and ignitor assembly	Model	FK0140
	Manufacturer	DIAMOND
Spark plug	Type and manufacturer	NGK : PLFR6A-11
	Thread size	mm 14, P = 1.25
	Spark gap	mm (in) 1.0 — 1.1 (0.039 — 0.043)

B: COMPONENT

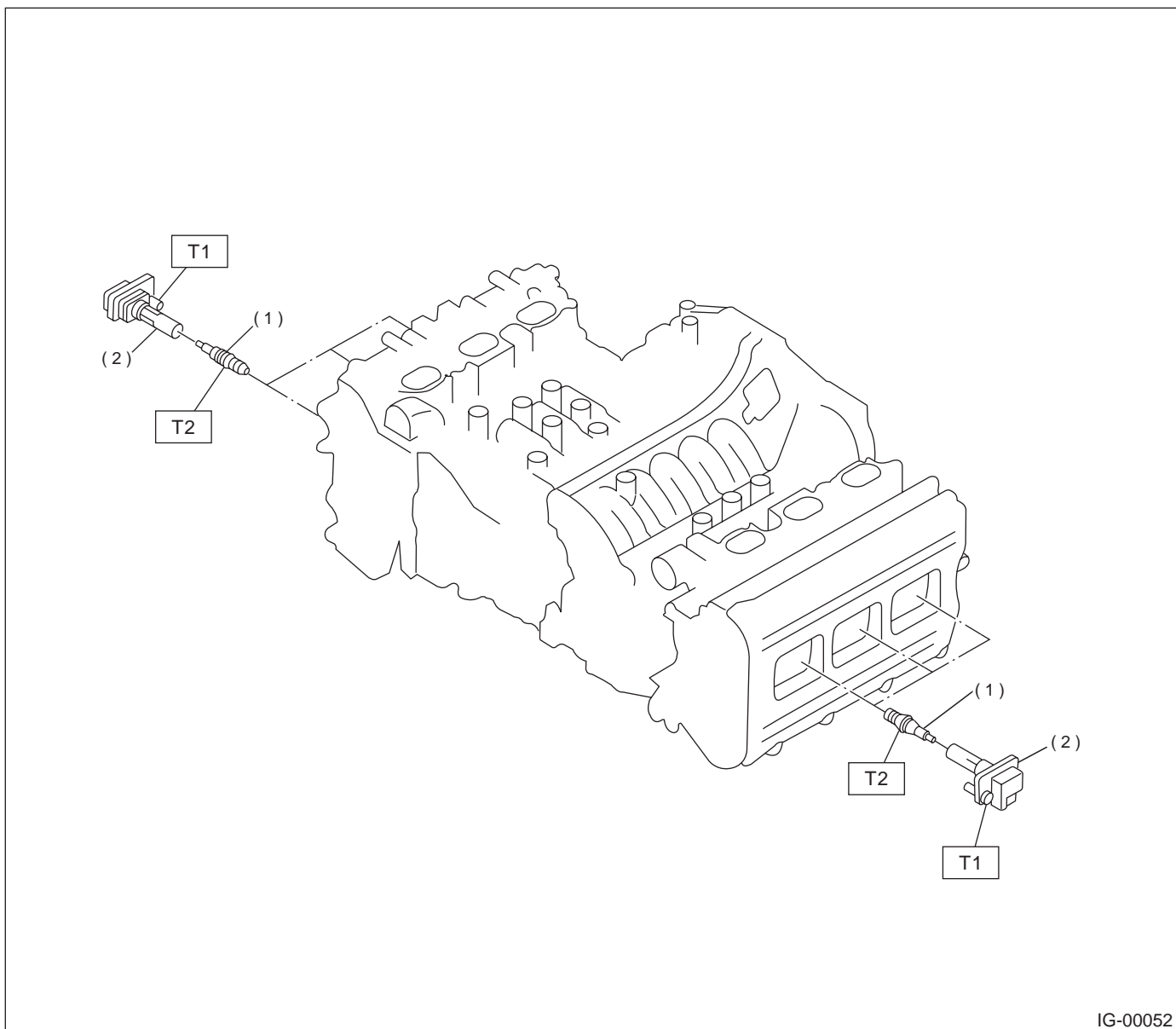

- (1) Spark plug
- (2) Ignition coil and ignitor ASSY

Tightening torque: N·m (kgf·m, ft·lb)

T1: 16 (1.6, 12)

T2: 21 (2.1, 15)

IG(H6DO)-2

GENERAL DESCRIPTION

IGNITION

C: CAUTION

- Wear working clothing, including a cap, protective goggles, and protective shoes during operation.
- Remove contamination including dirt and corrosion before removal, installation or disassembly.
- Keep the disassembled parts in order and protect them from dust or dirt.
- Before removal, installation or disassembly, be sure to clarify the failure. Avoid unnecessary removal, installation, disassembly, and replacement.
- Be careful not to burn your hands, because each part on the vehicle is hot after running.
- Be sure to tighten fasteners including bolts and nuts to the specified torque.
- Place shop jacks or safety stands at the specified points.
- Before disconnecting electrical connectors of sensors or units, be sure to disconnect ground cable from battery.