

## VALVE CLEARANCE

MECHANICAL

### 5. Valve Clearance

#### A: INSPECTION

##### CAUTION:

Inspection and adjustment of valve clearance should be performed while engine is cold.

- 1) Set the vehicle on the lift.
- 2) Disconnect battery ground cable.

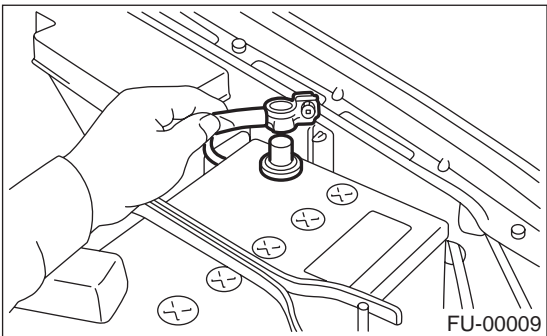

- 3) Lift up the vehicle.
- 4) Remove under cover.

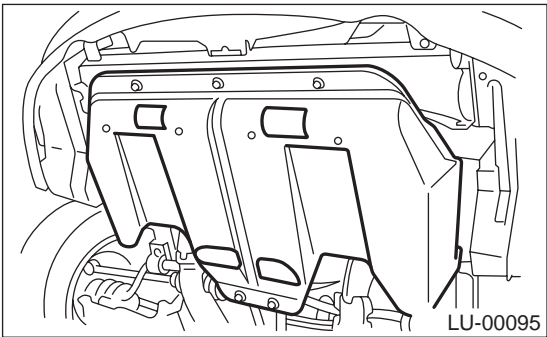

- 5) Lower the vehicle.
- 6) Place suitable container under the vehicle.
- 7) When inspecting RH side cylinder.
  - (1) Remove air intake duct and air cleaner case. <Ref. to IN(H6DO)-7, REMOVAL, Air Intake Duct.> and <Ref. to IN(H6DO)-5, REMOVAL, Air Cleaner.>
  - (2) Remove V-belt. <Ref. to ME(H6DO)-28, REMOVAL, V-belt.>
  - (3) Remove power steering hose from bracket.

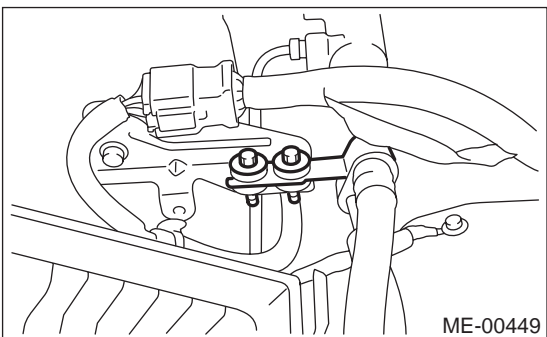

- (4) Remove bolts which install power steering pump bracket.

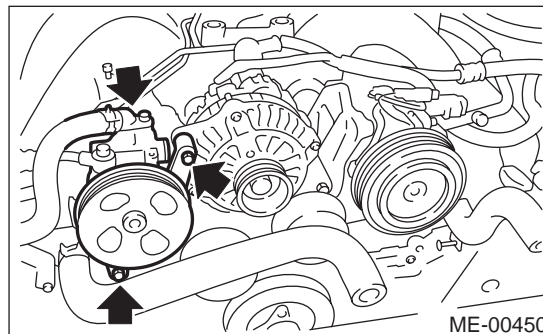

- (5) Remove power steering tank from the bracket by pulling it upward.

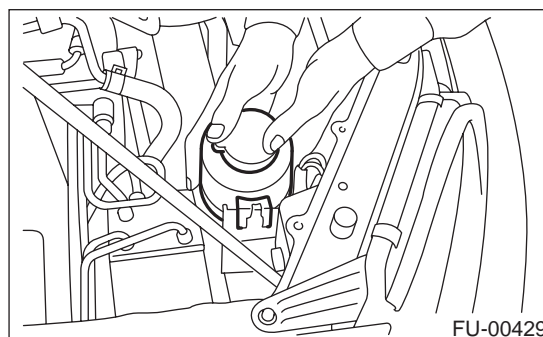

- (6) Place power steering pump on the right side wheel apron.

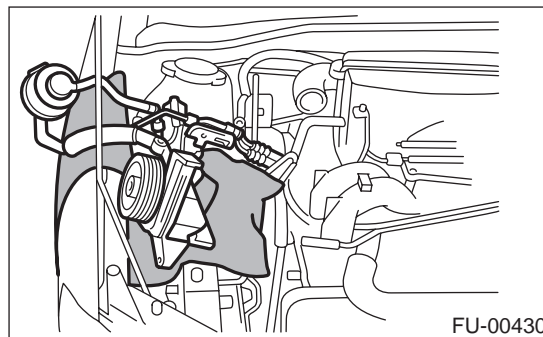

- (7) Remove fuel pipe protector RH.

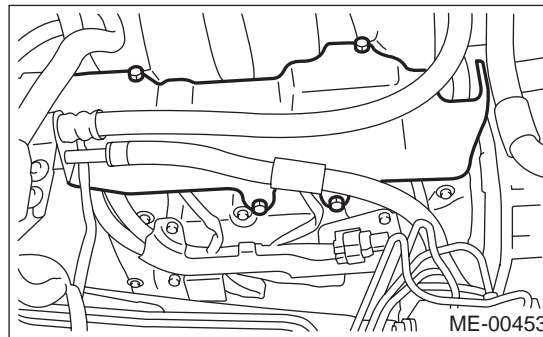

## VALVE CLEARANCE

MECHANICAL

(8) Disconnect fuel injector connectors.

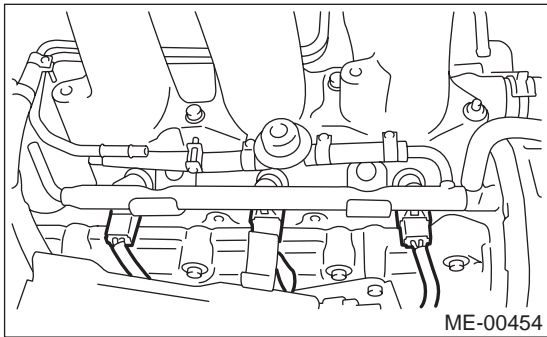

(9) Disconnect front oxygen (A/F) sensor connector.

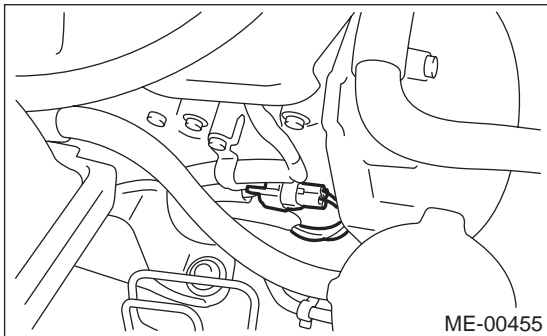

(10) Disconnect oil pressure switch connector.

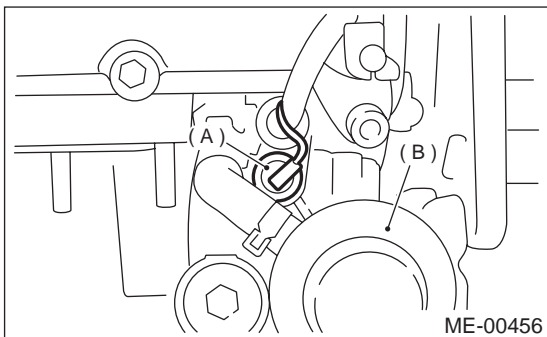

- (A) Oil pressure switch
- (B) Oil filter

(11) Remove ignition coils. <Ref. to IG(H6DO)-7, REMOVAL, Ignition Coil and Ignitor Assembly.>  
(12) Remove rocker cover RH. <Ref. to ME(H6DO)-50, REMOVAL, Camshaft.>

8) When inspecting LH side cylinder.

- (1) Set the vehicle on the lift.
- (2) Remove battery.
- (3) Remove washer tank mounting bolts.

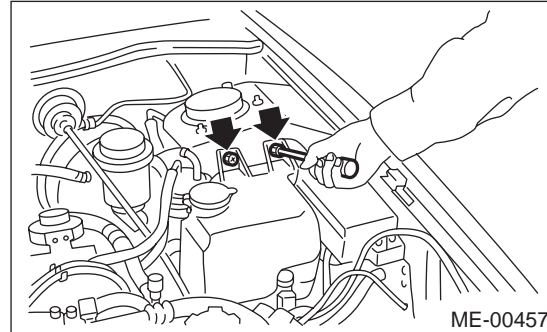

(4) Disconnect washer motor connectors.

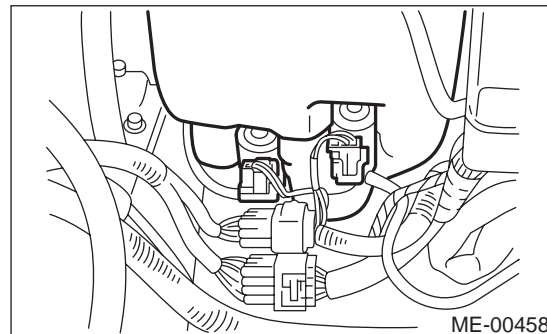

(5) Move washer tank upward.

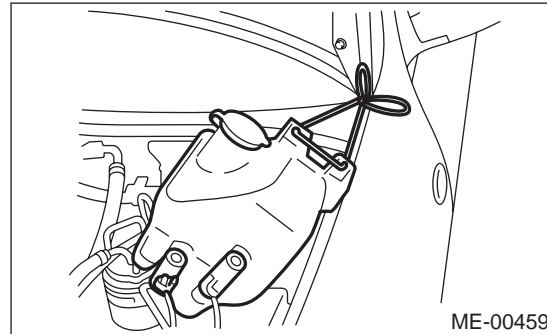

(6) Disconnect PCV and blow-by hose from rocker cover LH.

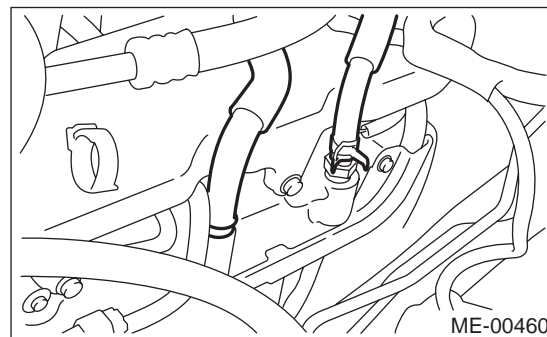

## VALVE CLEARANCE

### MECHANICAL

(7) Remove fuel pipe protector LH.

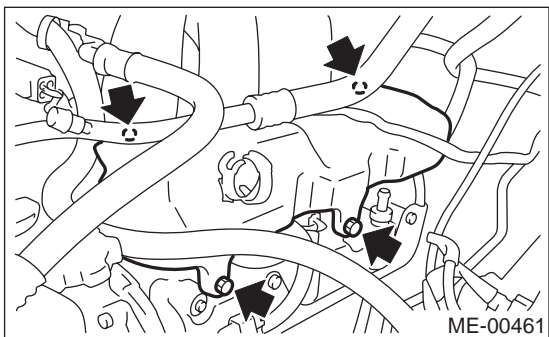

(8) Disconnect fuel injector connectors. (A)

(9) Disconnect front oxygen (A/F) sensor connector. (B)

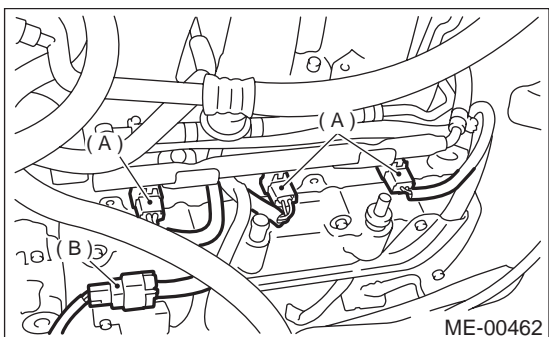

(10) Remove ignition coils. <Ref. to IG(H6DO)-7, REMOVAL, Ignition Coil and Ignitor Assembly.>

(11) Remove rocker cover LH. <Ref. to ME(H6DO)-50, REMOVAL, Camshaft.>

9) Using the ST, turn the crankshaft clockwise. Adjust the camshaft position so that the cam lobe is perpendicular to the shim as shown in the figure.  
ST 18252AA000 CRANKSHAFT SOCKET

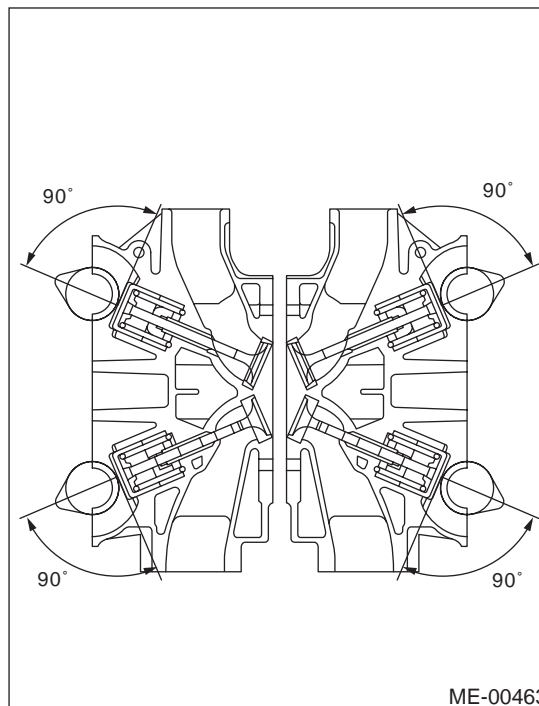

10) Measure intake valve and exhaust valve clearances by using thickness gauge (A).

**CAUTION:**  
Insert the thickness gauge in as horizontal a direction as possible with respect to the shim.

**Valve clearance:**

**Intake:**  $0.20^{+0.04}/_{-0.06}$  mm ( $0.0079^{+0.0016}/_{-0.0024}$  in)

**Exhaust:**  $0.25 \pm 0.05$  mm ( $0.0098 \pm 0.0020$  in)

**NOTE:**

If the measured value is not within specification, take notes of the value in order to adjust the valve clearance later on.

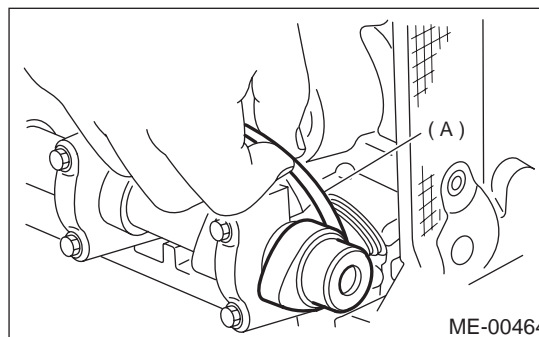

11) If necessary, adjust the valve clearance. <Ref. to ME(H6DO)-25, ADJUSTMENT, Valve Clearance.>

## VALVE CLEARANCE

MECHANICAL

12) Further turn crankshaft pulley clockwise. Using the same procedure described previously, then measure valve clearances again.

13) After inspection, install the related parts in the reverse order of removal.

### B: ADJUSTMENT

#### CAUTION:

Adjustment of valve clearance should be performed while engine is cold.

1) Measure all valve clearances. <Ref. to ME(H6DO)-22, INSPECTION, Valve Clearance.>

#### NOTE:

Record each valve clearance after it has been measured.

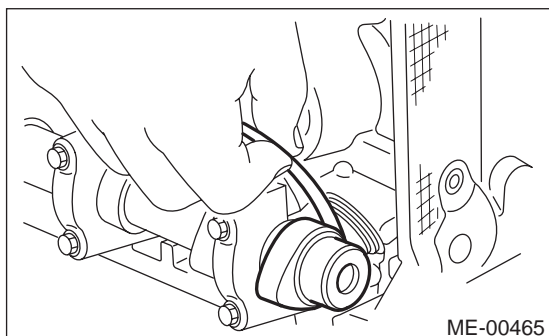

2) Remove shim from valve lifter.

(1) Prepare the ST.

ST 18329AA000 SHIM REPLACER  
<Ref. to ME(H6DO)-14, PREPARATION TOOL, General Description.>

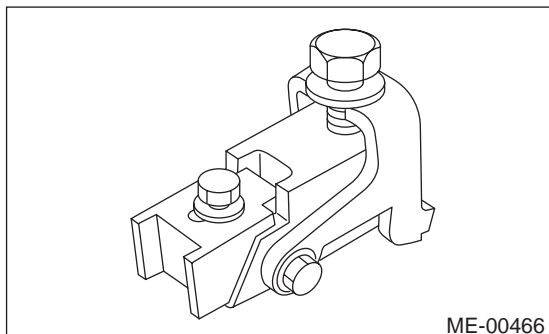

(2) Rotate the notch of the valve lifter outward by 45°.

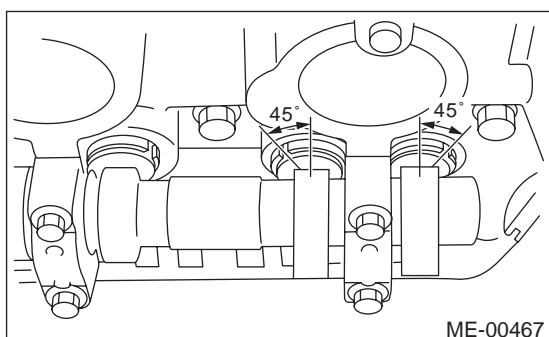

(3) Adjust SHIM REPLACER notch to valve lifter and set it.

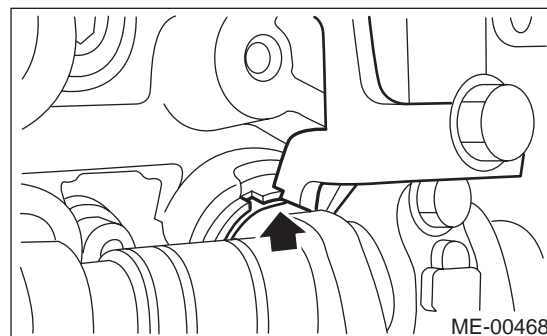

#### NOTE:

When setting, be careful SHIM REPLACER edge does not touch shim.

(4) Tighten bolt (A) and install it to the cylinder head.

(5) Tighten bolt (B) and insert the valve lifter.

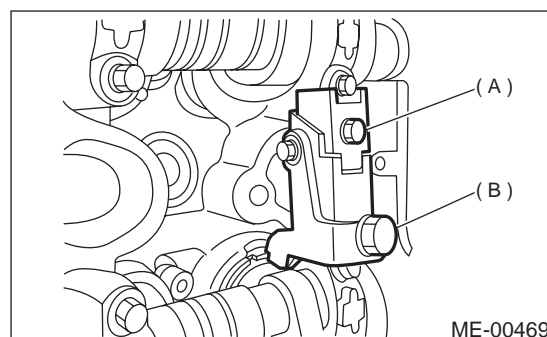

(6) Insert tweezers into the notch of the valve lifter, and take the shim out.

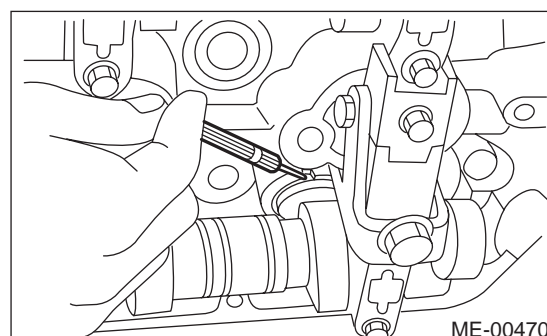

## VALVE CLEARANCE

### MECHANICAL

**NOTE:**

By using a magnet (A), the shim (B) can be taken out without dropping it.

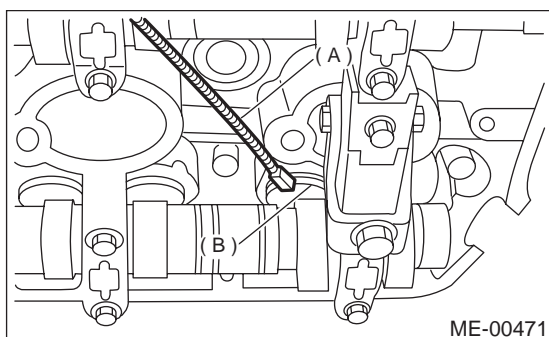

3) Measure thickness of shim with micrometer.

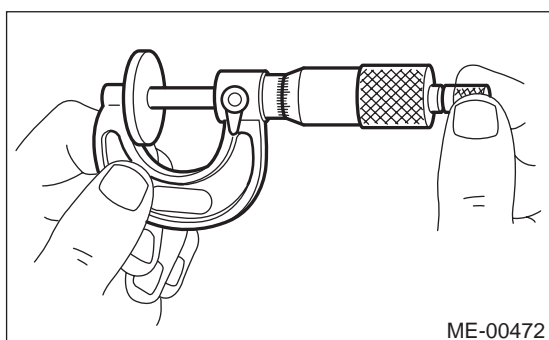

4) Select a shim of suitable thickness using measured valve clearance and shim thickness, by referring to the following table.

5) Set suitable shim selected in step 4) to valve lifter.

Unit: mm
Intake valve: $S = (V + T) - 0.20$
Exhaust valve: $S = (V + T) - 0.25$
S: Shim thickness to be used
V: Measured valve clearance
T: Shim thickness required

Part No.	Thickness mm (in)
13218 AK010	2.00 (0.0787)
13218 AK020	2.02 (0.0795)
13218 AK030	2.04 (0.0803)
13218 AK040	2.06 (0.0811)
13218 AK050	2.08 (0.0819)
13218 AK060	2.10 (0.0827)
13218 AK070	2.12 (0.0835)
13218 AK080	2.14 (0.0843)
13218 AK090	2.16 (0.0850)
13218 AK100	2.18 (0.0858)
13218 AK110	2.20 (0.0866)
13218 AE710	2.22 (0.0874)
13218 AE720	2.23 (0.0878)
13218 AE730	2.24 (0.0882)
13218 AE740	2.25 (0.0886)

Part No.	Thickness mm (in)
13218 AE750	2.26 (0.0890)
13218 AE760	2.27 (0.0894)
13218 AE770	2.28 (0.0898)
13218 AE780	2.29 (0.0902)
13218 AE790	2.30 (0.0906)
13218 AE800	2.31 (0.0909)
13218 AE810	2.32 (0.0913)
13218 AE820	2.33 (0.0917)
13218 AE830	2.34 (0.0921)
13218 AE840	2.35 (0.0925)
13218 AE850	2.36 (0.0929)
13218 AE860	2.37 (0.0933)
13218 AE870	2.38 (0.0937)
13218 AE880	2.39 (0.0941)
13218 AE890	2.40 (0.0945)
13218 AE900	2.41 (0.0949)
13218 AE910	2.42 (0.0953)
13218 AE920	2.43 (0.0957)
13218 AE930	2.44 (0.0961)
13218 AE940	2.45 (0.0965)
13218 AE950	2.46 (0.0969)
13218 AE960	2.47 (0.0972)
13218 AE970	2.48 (0.0976)
13218 AE980	2.49 (0.0980)
13218 AE990	2.50 (0.0984)
13218 AF000	2.51 (0.0988)
13218 AF010	2.52 (0.0992)
13218 AF020	2.53 (0.0996)
13218 AF030	2.54 (0.1000)
13218 AF040	2.55 (0.1004)
13218 AF050	2.56 (0.1008)
13218 AF060	2.57 (0.1012)
13218 AF070	2.58 (0.1016)
13218 AF090	2.60 (0.1024)
13218 AF100	2.61 (0.1028)
13218 AF110	2.62 (0.1031)
13218 AF120	2.63 (0.1035)
13218 AF130	2.64 (0.1039)
13218 AF140	2.65 (0.1043)
13218 AF150	2.66 (0.1047)
13218 AF160	2.67 (0.1051)
13218 AF170	2.68 (0.1055)
13218 AF180	2.69 (0.1059)
13218 AF190	2.70 (0.1063)
13218 AF200	2.71 (0.1067)
13218 AF210	2.72 (0.1071)
13218 AF220	2.73 (0.1075)
13218 AF230	2.74 (0.1079)
13218 AF240	2.75 (0.1083)
13218 AF250	2.76 (0.1087)
13218 AF260	2.77 (0.1091)

## VALVE CLEARANCE

MECHANICAL

---

Part No.	Thickness mm (in)
13218 AF270	2.78 (0.1094)
13218 AF280	2.79 (0.1098)
13218 AF290	2.80 (0.1102)
13218 AF300	2.81 (0.1106)

6) Inspect all valves for clearance again at this stage. If the valve clearance is not correct, repeat the procedure over again from the first step.

7) After inspection, install the related parts in the reverse order of removal.