

V-BELT

MECHANICAL

6. V-belt

A: REMOVAL

- 1) Fit the tool to the belt tensioner mounting bolt.
- 2) Turn the tool clockwise, and loosen the V-belt to remove.

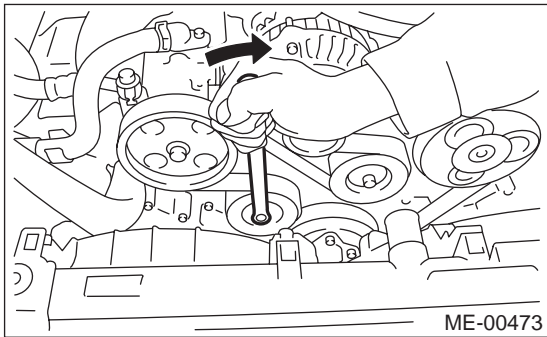

- 3) Remove the V-belt cover.

B: INSTALLATION

- 1) Install in the reverse order of removal.

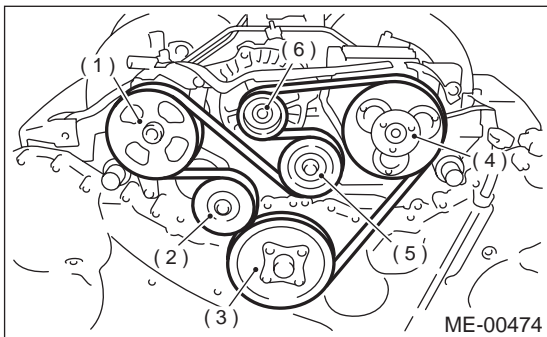

- (1) Power steering oil pump
- (2) Belt tension adjuster
- (3) Crankshaft pulley
- (4) A/C compressor
- (5) Belt idler
- (6) Generator

C: INSPECTION

- 1) Replace belts, if cracks, fraying or wear is found.
- 2) Check that the V-belt automatic tensioner indicator (A) is within the range (D).

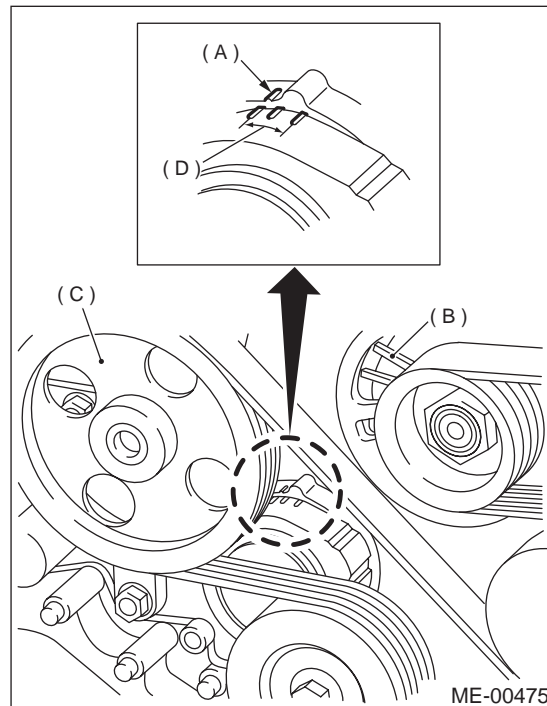

- (A) Indicator
- (B) Generator
- (C) Power steering oil pump
- (D) Service limit