

CYLINDER HEAD ASSEMBLY

MECHANICAL

17. Cylinder Head Assembly

A: REMOVAL

- 1) Remove crankshaft pulley. <Ref. to ME(H6DO)-38, REMOVAL, Crankshaft Pulley.>
- 2) Remove front chain cover. <Ref. to ME(H6DO)-39, REMOVAL, Front Chain Cover.>
- 3) Remove timing chain assembly. <Ref. to ME(H6DO)-41, REMOVAL, Timing Chain Assembly.>
- 4) Remove camshaft sprockets. <Ref. to ME(H6DO)-46, REMOVAL, Camshaft Sprocket.>
- 5) Remove crankshaft sprocket. <Ref. to ME(H6DO)-47, REMOVAL, Crankshaft Sprocket.>
- 6) Remove rear chain cover. <Ref. to ME(H6DO)-48, REMOVAL, Rear Chain Cover.>
- 7) Remove camshafts. <Ref. to ME(H6DO)-50, REMOVAL, Camshaft.>
- 8) Remove cylinder head bolts in numerical sequence shown in figure.

CAUTION:

Leave bolts (2) and (4) engaged by three or four threads to prevent cylinder head from falling.

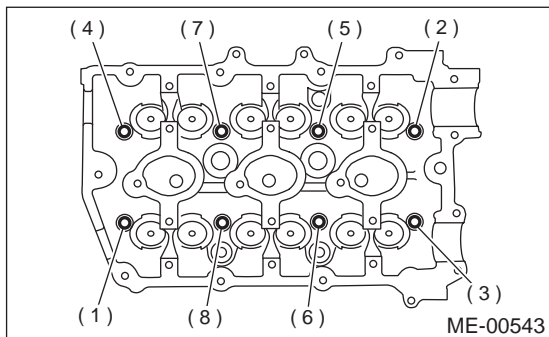

- 9) Tap cylinder head with a plastic hammer to separate it from cylinder block.
- 10) Remove bolts (2) and (4) to remove cylinder head.

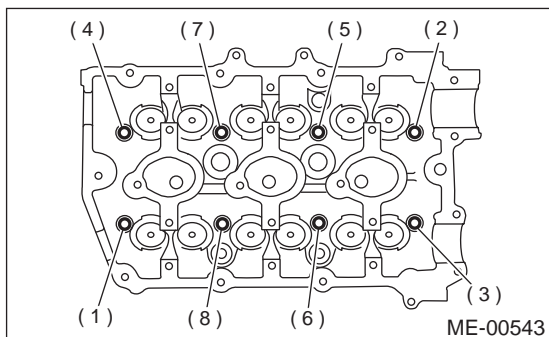

- 11) Remove cylinder head gasket.

CAUTION:

Do not scratch the mating surface of cylinder head and cylinder block.

- 12) Similarly, remove right side cylinder head.

B: INSTALLATION

- 1) Install cylinder head and gaskets on cylinder block.

CAUTION:

- Use new cylinder head gaskets.
- Be careful not to scratch the mating surface of cylinder block and oil pump.

- 2) Tighten cylinder head bolts.
 - (1) Coat the washers and threaded parts of the cylinder head bolts with engine oil.
 - (2) Install the cylinder head on the cylinder block and tighten the bolts in the numerical order shown in the figure to a tightening torque of 20 N·m (2.0 kgf-m, 14 ft-lb).
 - (3) Tighten the bolts in the numerical order shown in the figure to a tightening torque of 50 N·m (5.1 kgf-m, 37 ft-lb).
 - (4) Loosen all the bolts in 2 stages, 180° at a time, in the reverse order of tightening.
 - (5) Tighten the bolts in the numerical order shown in the figure to a tightening torque of 25 N·m (2.5 kgf-m, 18 ft-lb).
 - (6) Tighten the bolts in the numerical order shown in the figure to a tightening torque of 25 N·m (2.5 kgf-m, 18 ft-lb).
 - (7) Tighten all the bolts 90° in the numerical order shown in the figure.
 - (8) Tighten the (1) to (4) bolts 90° again in the numerical order shown in the figure.
 - (9) Tighten the (5) to (8) bolts 45° again in the numerical order shown in the figure.

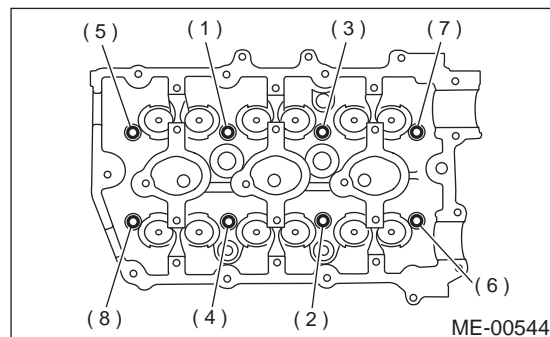

- 3) Install camshafts. <Ref. to ME(H6DO)-50, INSTALLATION, Camshaft.>
- 4) Install rear chain cover. <Ref. to ME(H6DO)-48, INSTALLATION, Rear Chain Cover.>
- 5) Install crankshaft sprocket. <Ref. to ME(H6DO)-47, INSTALLATION, Crankshaft Sprocket.>
- 6) Install camshaft sprockets. <Ref. to ME(H6DO)-46, INSTALLATION, Camshaft Sprocket.>
- 7) Install timing chain assembly. <Ref. to ME(H6DO)-42, INSTALLATION, Timing Chain Assembly.>
- 8) Install front chain cover. <Ref. to ME(H6DO)-39, INSTALLATION, Front Chain Cover.>

CYLINDER HEAD ASSEMBLY

MECHANICAL

9) Install crankshaft pulley. <Ref. to ME(H6DO)-38, INSTALLATION, Crankshaft Pulley.>

C: DISASSEMBLY

- 1) Place cylinder head on ST.
ST 18250AA000 CYLINDER HEAD TABLE
- 2) Remove valve shims and valve lifters.
- 3) Set ST on valve spring retainer. Compress valve spring and remove the valve spring retainer key. Remove each valve and valve spring.
ST 499718000 VALVE SPRING REMOVER

CAUTION:

- For correct re-installation, keep removed parts in order in their original positions.
- Mark each valve to prevent confusion.
- Use extreme care not to damage the lips of the intake valve oil seals and exhaust valve stem seals.

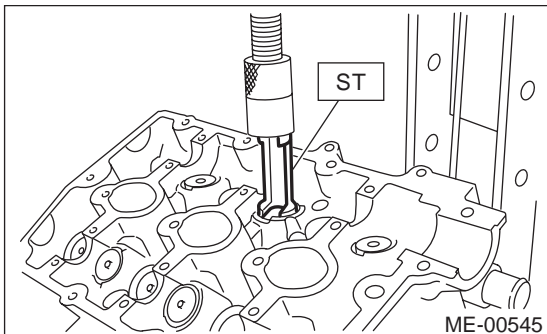

D: ASSEMBLY

- 1) Installation of valve spring and valve
(1) Place cylinder head on ST.
ST 18250AA000 CYLINDER HEAD TABLE
- (2) Coat stem of each valve with engine oil and insert valve into valve guide.

CAUTION:

When inserting valve into valve guide, use special care not to damage the stem seal lip.

- (3) Install valve spring and retainer.

CAUTION:

- Be sure to install the valve springs with their close-coiled end facing the seat on the cylinder head.
- Install valve spring with the painted surface facing the retainer side.

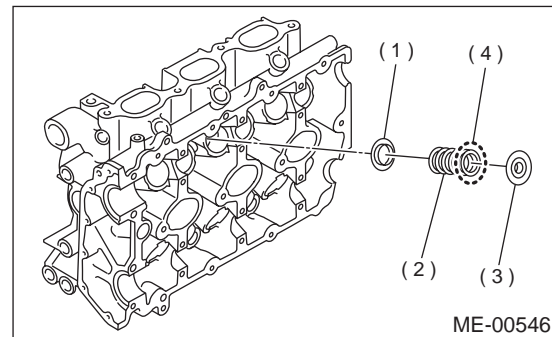

- (1) Seat
- (2) Valve spring
- (3) Retainer
- (4) Painted face

- (4) Set ST on valve spring.
ST 499718000 VALVE SPRING REMOVER

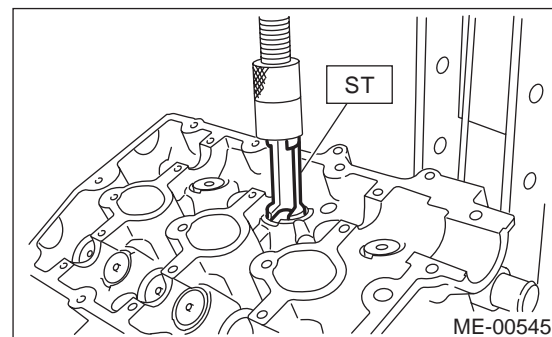

- (5) Compress valve spring and fit valve spring retainer key.
- (6) After installing, tap valve spring retainers lightly with wooden hammer for better seating.
- 2) Apply oil to the surface of the valve lifter and valve shim.
- 3) Install valve lifter and valve shim.

CYLINDER HEAD ASSEMBLY

MECHANICAL

E: INSPECTION

1. VALVE SPRING

- 1) Check valve springs for damage, free length, and tension. Replace valve spring if it is not to the specifications presented below.
- 2) To measure the squareness of the valve spring, stand the spring on a surface plate and measure its deflection at the top using a try square.

Free length	46.79 mm (1.8421 in)
Squareness	2.5°, 2.0 mm (0.079 in)

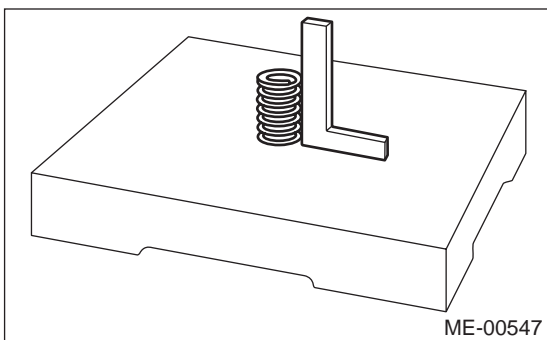

2. INTAKE AND EXHAUST VALVE STEM SEAL

Replace oil seal with new one, if lip is damaged or spring out of place, or when the surfaces of intake valve and valve seat are reconditioned or intake valve guide is replaced. Use pliers to pinch and remove oil seal from valve.

- 1) Place cylinder head on ST1.
- 2) Press-fit oil seal to the specified dimension indicated in the figure using ST2.

CAUTION:

- Apply engine oil to stem seal before press-fitting.
- When press-fitting stem seal, do not use hammer or strike in.

ST1 18250AA000 CYLINDER HEAD TABLE
ST2 498857100 VALVE OIL SEAL GUIDE

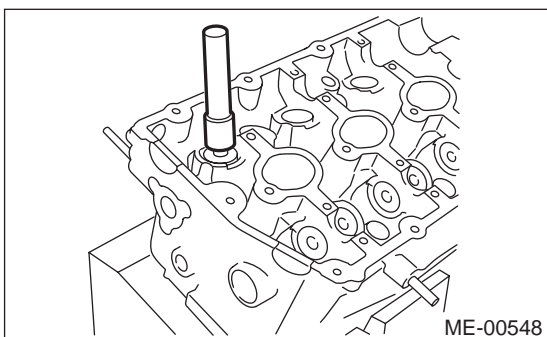

3. VALVE LIFTER

- 1) Check valve lifter visually.
- 2) Measure outer diameter of valve lifter.

Outer diameter:

33.959 — 33.975 mm (1.3370 — 1.3376 in)

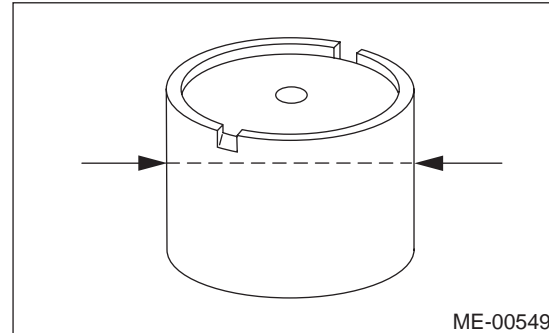

- 3) Measure inner diameter of valve lifter mating part on cylinder head.

Inner diameter:

34.006 — 34.016 mm (1.3388 — 1.3392 in)

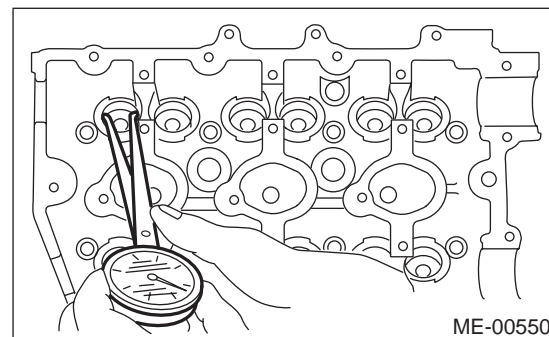

CAUTION:

If difference between outer diameter of valve lifter and inner diameter of valve lifter mating part is over the limit, replace cylinder head.

Standard:

0.019 — 0.057 mm (0.0007 — 0.0022 in)

Limit:

0.100 mm (0.0039 in)

CYLINDER HEAD ASSEMBLY

MECHANICAL

F: ADJUSTMENT

1. CYLINDER HEAD

1) Make sure that no crack or other damage exists. In addition to visual inspection, inspect important areas by means of red lead check.

Also make sure that gasket installing surface shows no trace of gas and water leaks.

2) Place cylinder head on ST.

ST 18250AA000 CYLINDER HEAD TABLE

3) Measure the warping of the cylinder head surface that mates with crankcase using a straight edge and thickness gauge.

If the warping exceeds 0.05 mm (0.0020 in), re-grind the surface with a surface grinder.

Warping limit:

0.05 mm (0.0020 in)

Grinding limit:

0.1 mm (0.004 in)

Standard height of cylinder head:

124 mm (4.88 in)

CAUTION:

Uneven torque for the cylinder head bolts can cause warping. When reassembling, pay special attention to the torque so as to tighten evenly.

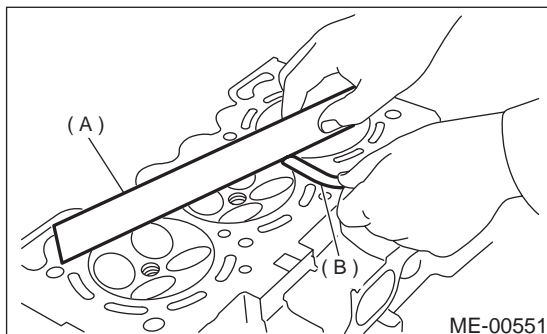

(A) Straight edge

(B) Thickness gauge

2. VALVE SEAT

Inspect intake and exhaust valve seats, and correct the contact surfaces with valve seat cutter if they are defective or when valve guides are replaced.

Valve seat width: W

Intake

Standard

1.0 mm (0.039 in)

Limit

1.7 mm (0.067 in)

Exhaust

Standard

1.5 mm (0.059 in)

Limit

2.2 mm (0.087 in)

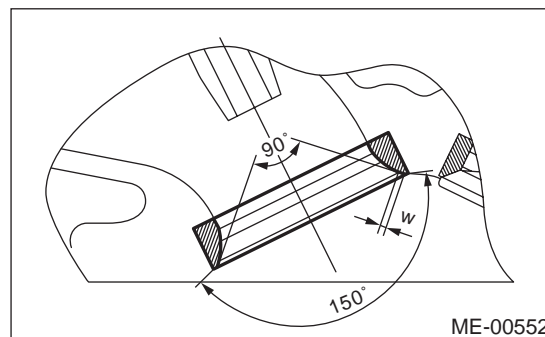

3. VALVE GUIDE

1) Check the clearance between valve guide and stem. The clearance can be checked by measuring the outside diameter of valve stem and the inside diameter of valve guide with outside and inside micrometers respectively.

Clearance between the valve guide and valve stem:

Standard

Intake

0.030 — 0.057 mm (0.0012 — 0.0022 in)

Exhaust

0.040 — 0.067 mm (0.0016 — 0.0026 in)

Limit

0.15 mm (0.0059 in)

CYLINDER HEAD ASSEMBLY

MECHANICAL

2) If the clearance between valve guide and stem exceeds the limit, replace valve guide or valve itself whichever shows greater amount of wear. See following procedure for valve guide replacement.

Valve guide inner diameter:

5.500 — 5.512 mm (0.2165 — 0.2170 in)

Valve stem outer diameter:

Intake

5.455 — 5.470 mm (0.2148 — 0.2154 in)

Exhaust

5.455 — 5.460 mm (0.2148 — 0.2150 in)

(1) Place cylinder head on ST1 with the combustion chamber upward so that valve guides enter the holes in ST1.

(2) Insert ST2 into valve guide and press it down to remove valve guide.

ST1 18250AA000 CYLINDER HEAD TABLE
ST2 499765700 VALVE GUIDE REMOVER

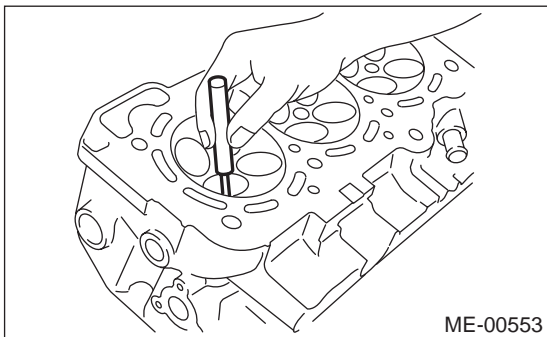

(3) Turn cylinder head upside down and place ST as shown in the figure.

ST 18251AA000 VALVE GUIDE ADJUSTER

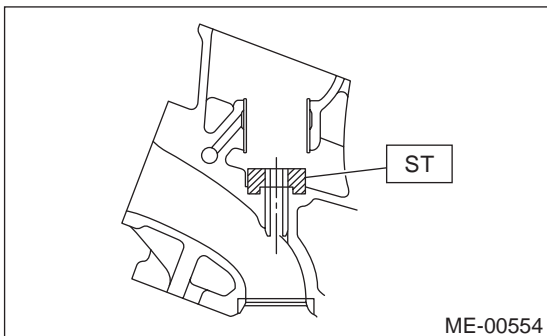

(4) Before installing new valve guide, make sure that neither scratches nor damages exist on the inside surface of the valve guide holes in cylinder head.

(5) Put new valve guide in cylinder, and insert ST1 into valve guide. Press in until the valve guide upper end is flush with the upper surface of ST2.

ST1 499765700 VALVE GUIDE REMOVER
ST2 18251AA000 VALVE GUIDE ADJUSTER

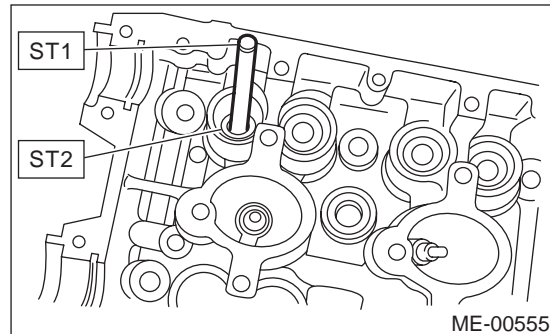

(6) Check the valve guide protrusion.

Valve guide protrusion: L

12.3 — 12.7 mm (0.484 — 0.500 in)

(7) Ream the inside of valve guide with ST. Gently rotate the reamer clockwise while pressing it lightly into valve guide, and return it also rotating clockwise. After reaming, clean valve guide to remove chips.

ST 499765900 VALVE GUIDE REAMER

CAUTION:

- Apply engine oil to the reamer when reaming.
- If the inner surface of the valve guide is torn, the edge of the reamer should be slightly ground with an oil stone.
- If the inner surface of the valve guide becomes lustrous and the reamer does not chip, use a new reamer or remedy the reamer.

(8) Recheck the contact condition between valve and valve seat after replacing valve guide.

CYLINDER HEAD ASSEMBLY

MECHANICAL

4. INTAKE AND EXHAUST VALVE

1) Inspect the flange and stem of valve, and replace if damaged, worn, or deformed, or if "H" is less than the specified limit.

H:

Intake

Standard

1.0 mm (0.039 in)

Limit

0.8 mm (0.031 in)

Exhaust

Standard

1.2 mm (0.047 in)

Limit

0.8 mm (0.031 in)

Valve overall length:

Intake

103.5 mm (4.075 in)

Exhaust

103.2 mm (4.063 in)

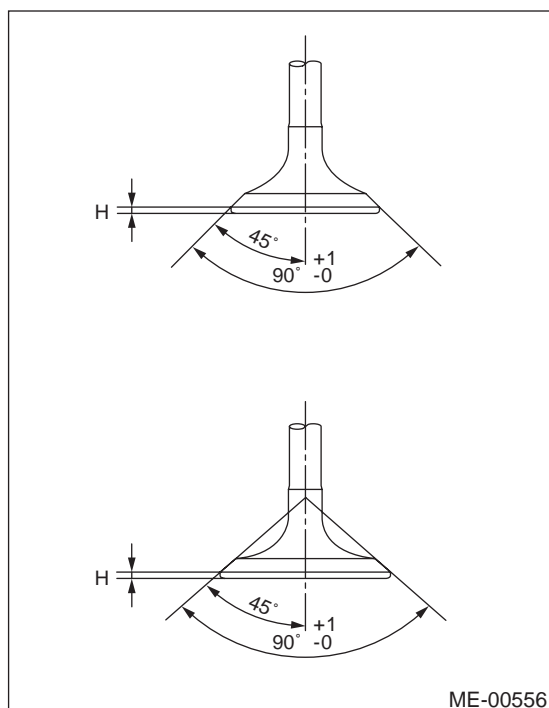

2) Put a small amount of grinding compound on the seat surface and lap the valve and seat surface. Install a new intake valve oil seal after lapping.