

GENERATOR

STARTING/CHARGING SYSTEMS

3. Generator

A: REMOVAL

- 1) Disconnect battery ground cable.

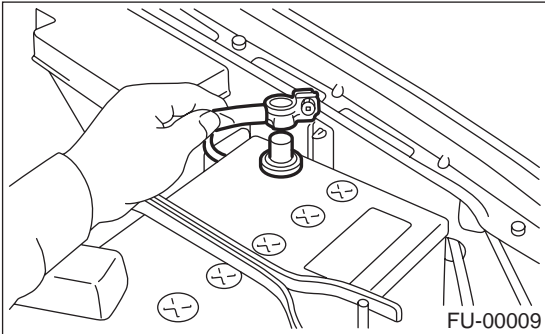

- 2) Disconnect connector and terminal from generator.

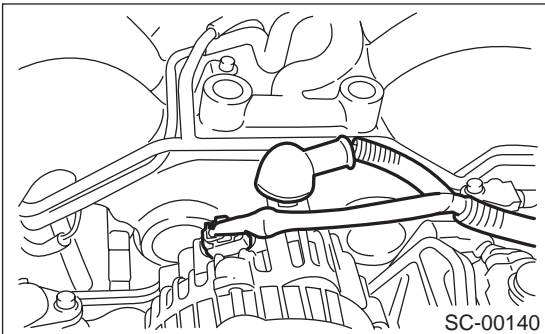

- 3) Remove V-belt. <Ref. to ME(H6DO)-28, REMOVAL, V-belt.>

- 4) Remove bolt (A), and loosen bolt (B). Then, remove generator from bracket.

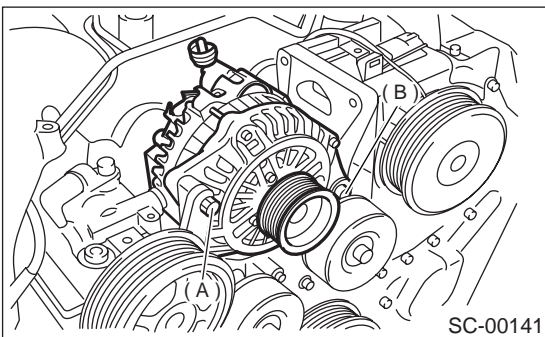

B: INSTALLATION

Install in the reverse order of removal.

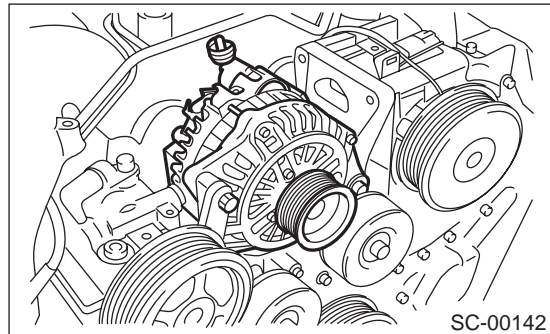

C: DISASSEMBLY

- 1) Remove the four through-bolts.

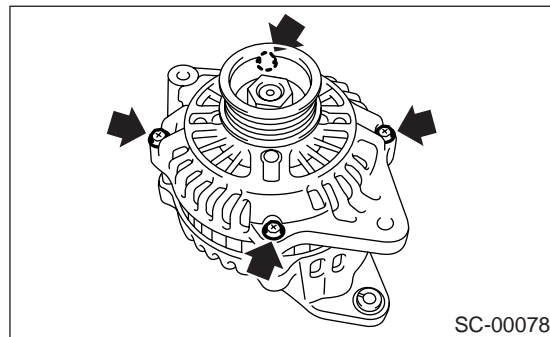

- 2) Heat the portion (A) of rear cover to 50°C (122°F) with heater drier.

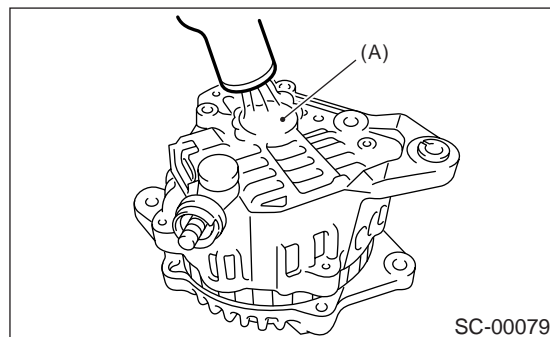

- 3) Then insert the tip of a flat tip screwdriver into the gap between stator core and front cover. Pry them apart to disassemble.

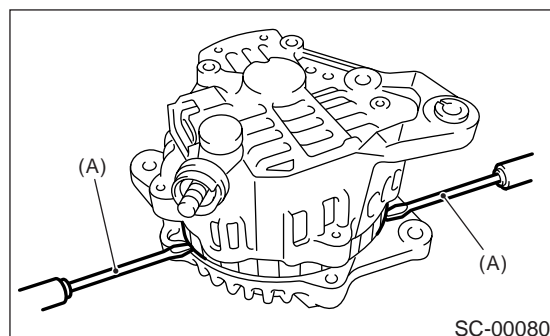

(A) Screwdriver

GENERATOR

STARTING/CHARGING SYSTEMS

4) Hold the rotor with a vise and remove pulley nut.

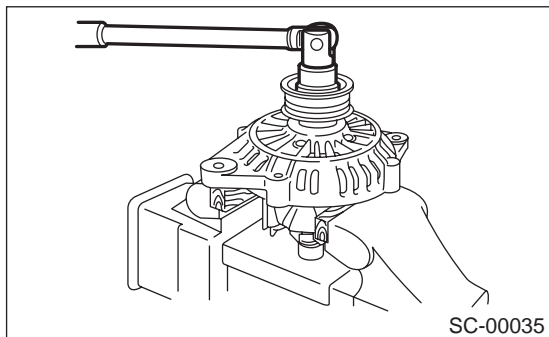

CAUTION:

When holding the rotor with vise, insert aluminum plates or wood pieces on the contact surfaces of vise to prevent rotor from damage.

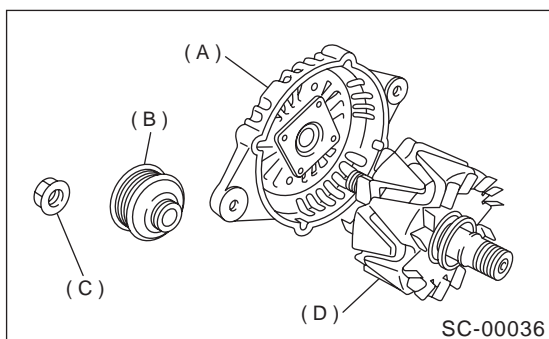

- (A) Front cover
- (B) Pulley
- (C) Nut
- (D) Rotor

5) Remove the ball bearing as follows.

(1) Remove the bolt, and then remove the bearing retainer.

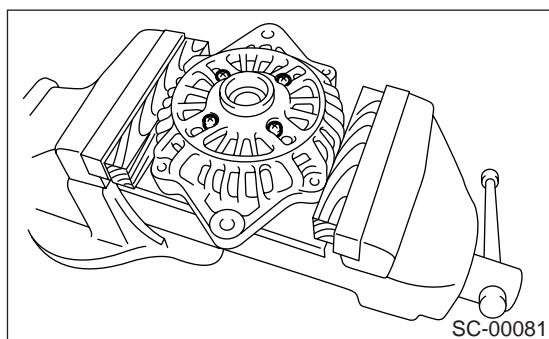

(2) Firmly install an appropriate tool (such as a fit socket wrench) to bearing inner race.

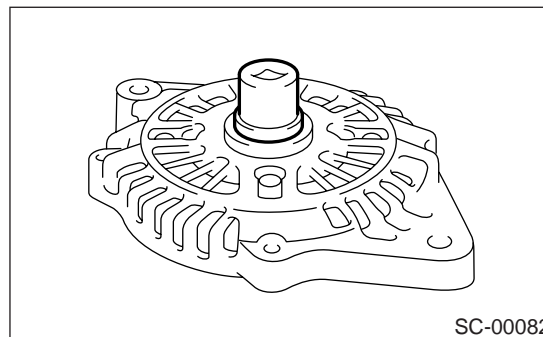

(3) Push the ball bearing off the front cover using a press.

6) Remove the bearing from rotor using a bearing puller.

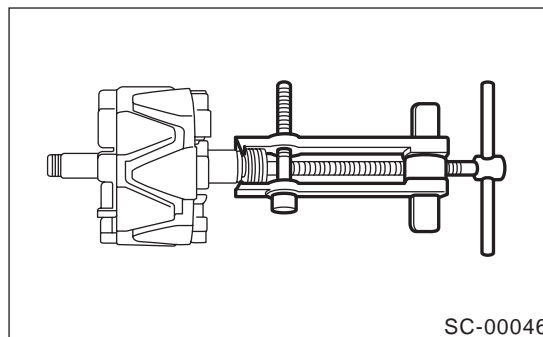

7) Unsolder connection between rectifier and stator coil to remove the stator coil.

CAUTION:

Do not allow the 180 — 270 W soldering bit to contact the terminals for more than 5 seconds at a time because the rectifier cannot withstand heat very well.

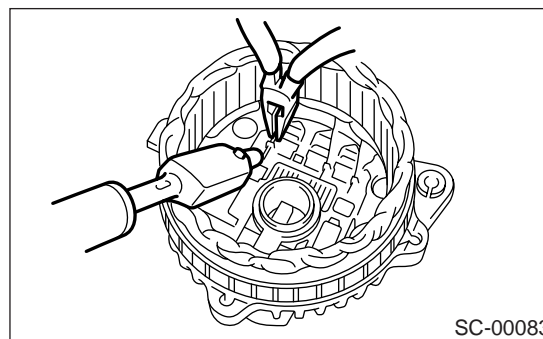

GENERATOR

STARTING/CHARGING SYSTEMS

8) Remove the IC regulator as follows.

(1) Remove the screws which secure IC regulator to rear cover.

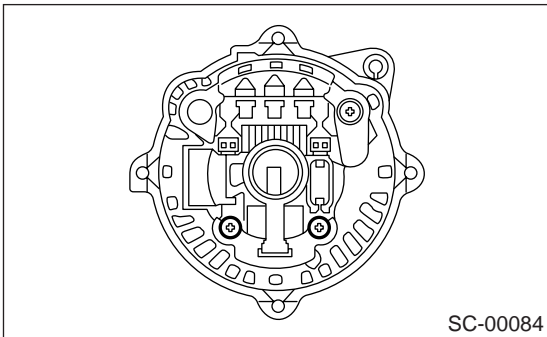

(2) Unsolder the connection between IC regulator and rectifier to remove the IC regulator.

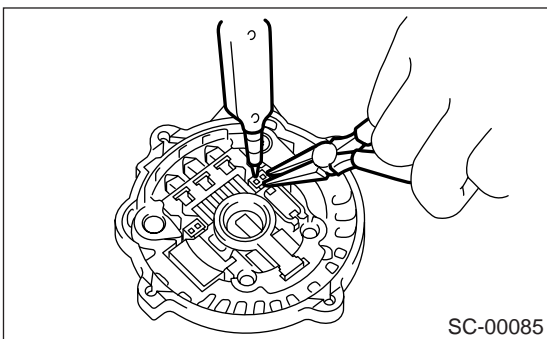

9) Remove the brush as follows.

(1) Remove cover A.

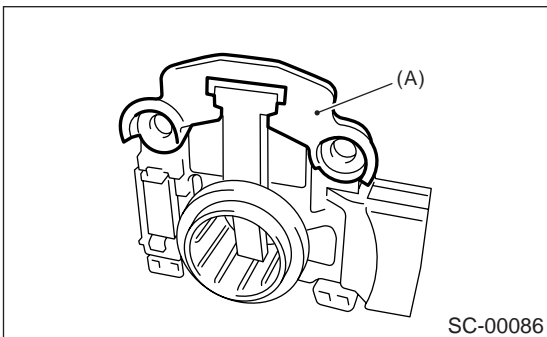

(A) Cover A

(2) Remove the cover B.

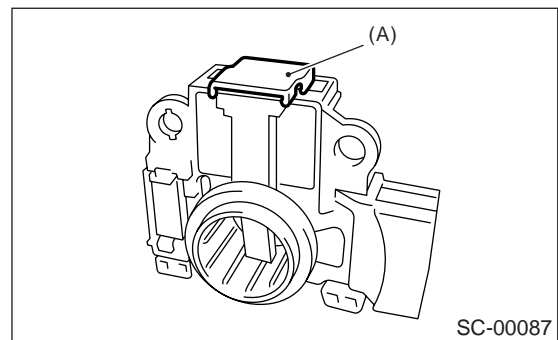

(A) Cover B

(3) Separate the brush from connection to remove.

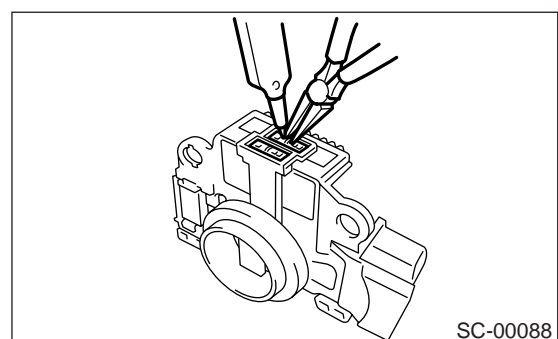

10) Remove the rectifier as follows.

(1) Remove the bolts which secure the rectifier.

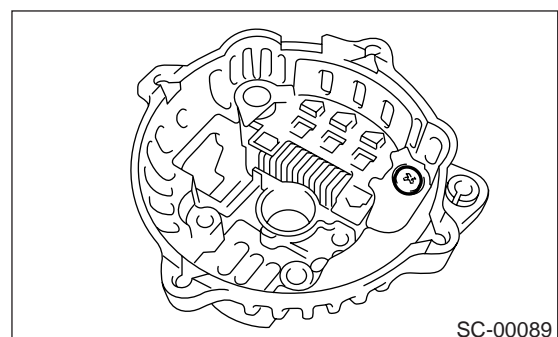

(2) Remove the cover of terminal B.

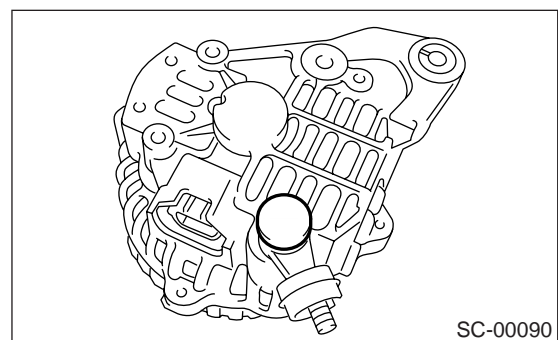

GENERATOR

STARTING/CHARGING SYSTEMS

- (3) Remove the nut of terminal B, and then remove the rectifier.

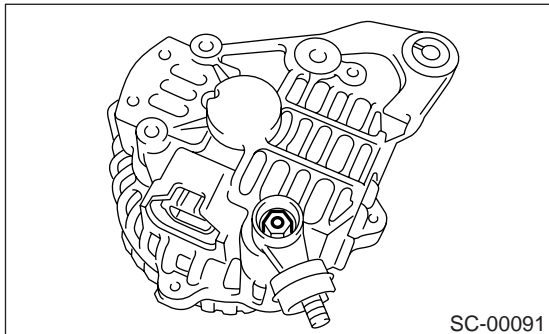

D: ASSEMBLY

To assemble, reverse order of disassembly.

1) Pulling up brush

Before assembling, press the brush down into brush holder, and then fix them in that position by passing a [1 mm (0.08 in) dia. length 4 to 5 cm (1.6 to 2.0 in)] wire through the hole shown in the figure.

CAUTION:

Be sure to remove the wire after reassembly.

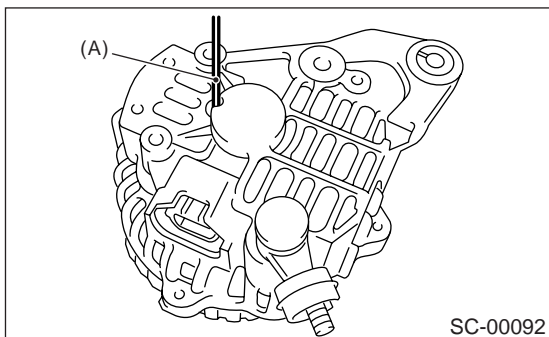

(A) Wire

2) Install the ball bearing.

- (1) Set the ball bearing on the front cover, and then securely install an appropriate tool (such as a fit socket wrench) to the bearing outer race.
 - (2) Press the ball bearing into the specified position using a press.
 - (3) Install the bearing retainer.
- 3) Press the bearing (rear side) into the rotor shaft using a press to install.
- 4) Heat the bearing box in rear cover [50 to 60°C (122 to 140°F)], and then press the rear bearing into rear cover.

CAUTION:

Grease should not be applied to rear bearing. Remove the oil completely if it is found on bearing box.

- 5) After reassembly, turn the pulley by hand to check that rotor turns smoothly.

E: INSPECTION

1. DIODE

CAUTION:

Never use a mega tester (measuring use for high voltage) or any other similar measure for this test; otherwise, the diodes may be damaged.

1) Checking positive diode

Check for continuity between the diode lead and positive side heat sink. The positive diode is in good condition if resistance is 1 Ω or less only in the direction from the diode lead to heat sink.

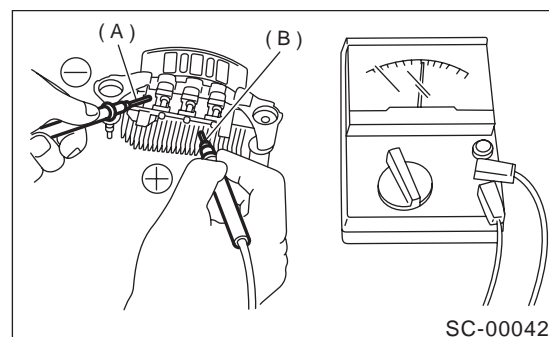

- (A) Diode lead
(B) Heat sink (Positive side)

2) Checking negative diode

Check for continuity between the negative side heat sink and diode lead. The negative diode is in good condition if resistance is 1 Ω or less only in the direction from the heat sink to diode lead.

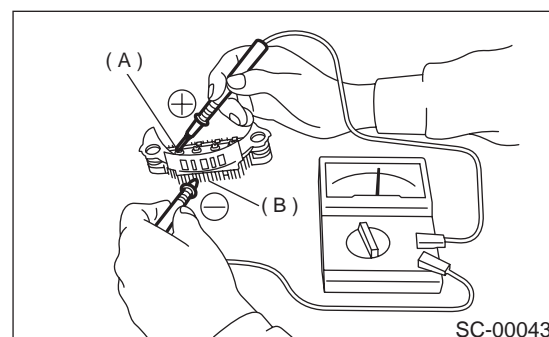

- (A) Diode lead
(B) Heat sink (Negative side)

GENERATOR

STARTING/CHARGING SYSTEMS

2. ROTOR

1) Slip ring surface

Inspect the slip rings for contamination or any roughness of the sliding surface. Repair the slip ring surface using a lathe or sand paper.

2) Slip ring outer diameter

Measure the slip ring outer diameter. If the slip ring is worn replace rotor assembly.

Slip ring outer diameter:

Standard

22.7 mm (0.894 in)

Limit

22.1 mm (0.870 in)

3) Continuity test

Check the resistance between slip rings using circuit tester.

If the resistance is not within specification, replace the rotor assembly.

Specified resistance:

Approx. 2.0 — 2.4 Ω

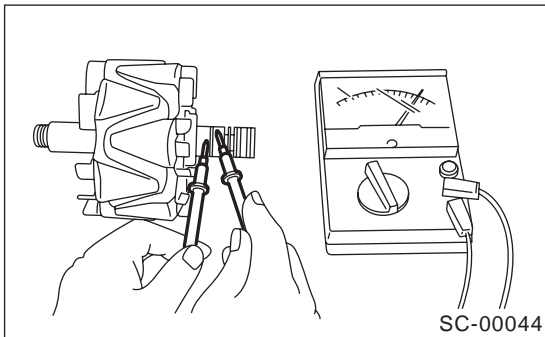

4) Insulation test

Check the continuity between slip ring and rotor core or shaft. If resistance is 1 Ω or less, the rotor coil is grounded, and so replace the rotor assembly.

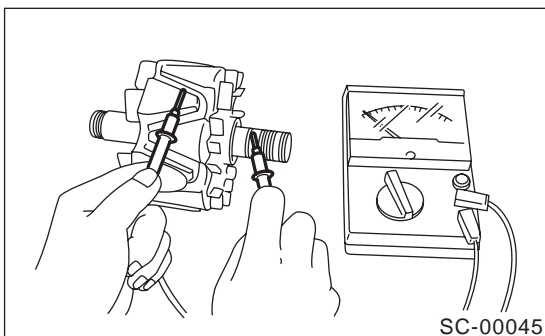

5) Ball bearing (rear side)

Check the rear ball bearing. Replace if it is noisy or if the rotor does not turn smoothly.

3. STATOR

1) Continuity test

Inspect the stator coil for continuity between each end of the lead wires. If resistance is 1 M Ω or more, the lead wire is broken, and so replace the stator assembly.

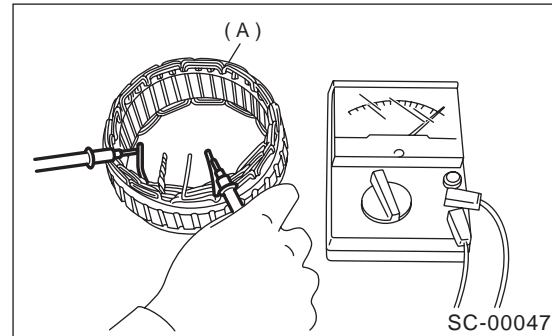

(A) Stator

2) Insulation test

Inspect the stator coil for continuity between stator core and each end of lead wire. If resistance is 1 Ω or less, the stator coil is grounded, and so replace the stator assembly.

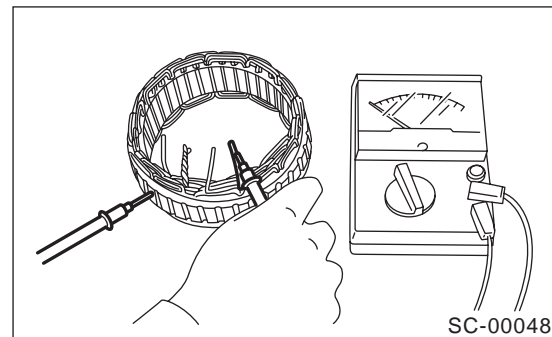

4. BRUSH

1) Measure the length of each brush. If wear exceeds the service limit, replace the brush. Each brush has the service limit mark (A) on it.

Brush length:

Standard

18.5 mm (0.728 in)

Service limit

5.0 mm (0.197 in)

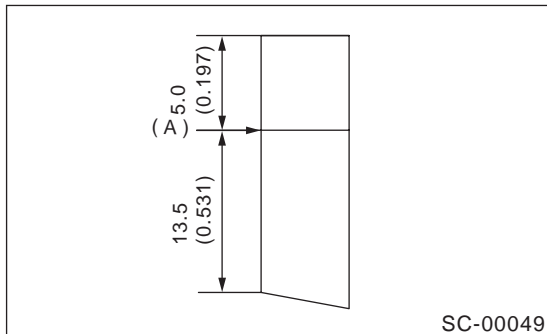

2) Checking brush spring for proper pressure

Using a spring pressure indicator, push the brush into the brush holder until its tip protrudes 2 mm (0.08 in). Then measure the pressure of brush spring. If the pressure is less than 2.2 N (224 g, 7.91 oz), replace the brush spring with a new one. The new spring must have a pressure of 4.8 to 6.0 N (489 to 612 g, 17.26 to 21.60 oz).

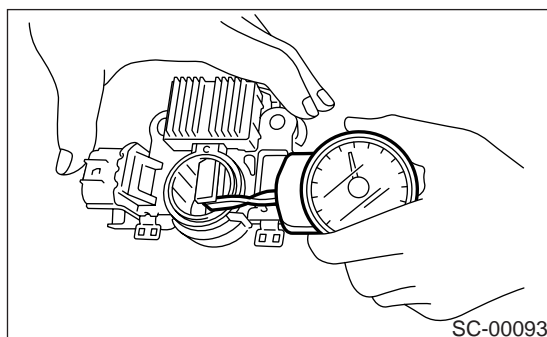

5. BEARING (FRONT SIDE)

Check the front ball bearing. If the resistance is felt while rotating, or if abnormal noise is heard, replace the ball bearing.