

FOREWORD

FOREWORD

1. Foreword

A: FOREWORD

These manuals are used when performing maintenance, repair, or diagnosis of the Subaru Legacy.

Applied model: BE***** and BH***** from 2003MY.

The manuals contain the latest information at the time of publication. Changes in specifications, methods, etc. may be made without notice.

HOW TO USE THIS MANUALS

HOW TO USE THIS MANUALS

1. How to Use This Manuals

A: HOW TO USE THIS MANUALS

1. STRUCTURE

Each section consists of SCT that are broken down into SC that are divided into sections for each component. The specification, maintenance and other information for the components are included, and diagnosis information has also been added where necessary.

2. INDEX

The first page has an index with tabs.

HOW TO USE THIS MANUALS

HOW TO USE THIS MANUALS

3. COMPONENTS

Illustrations are listed for each component. The information necessary for repair work (tightening torque, grease up points, etc.) is described on these illustrations. Information is described using symbol. To order the parts, refer to parts catalogue.

Example:

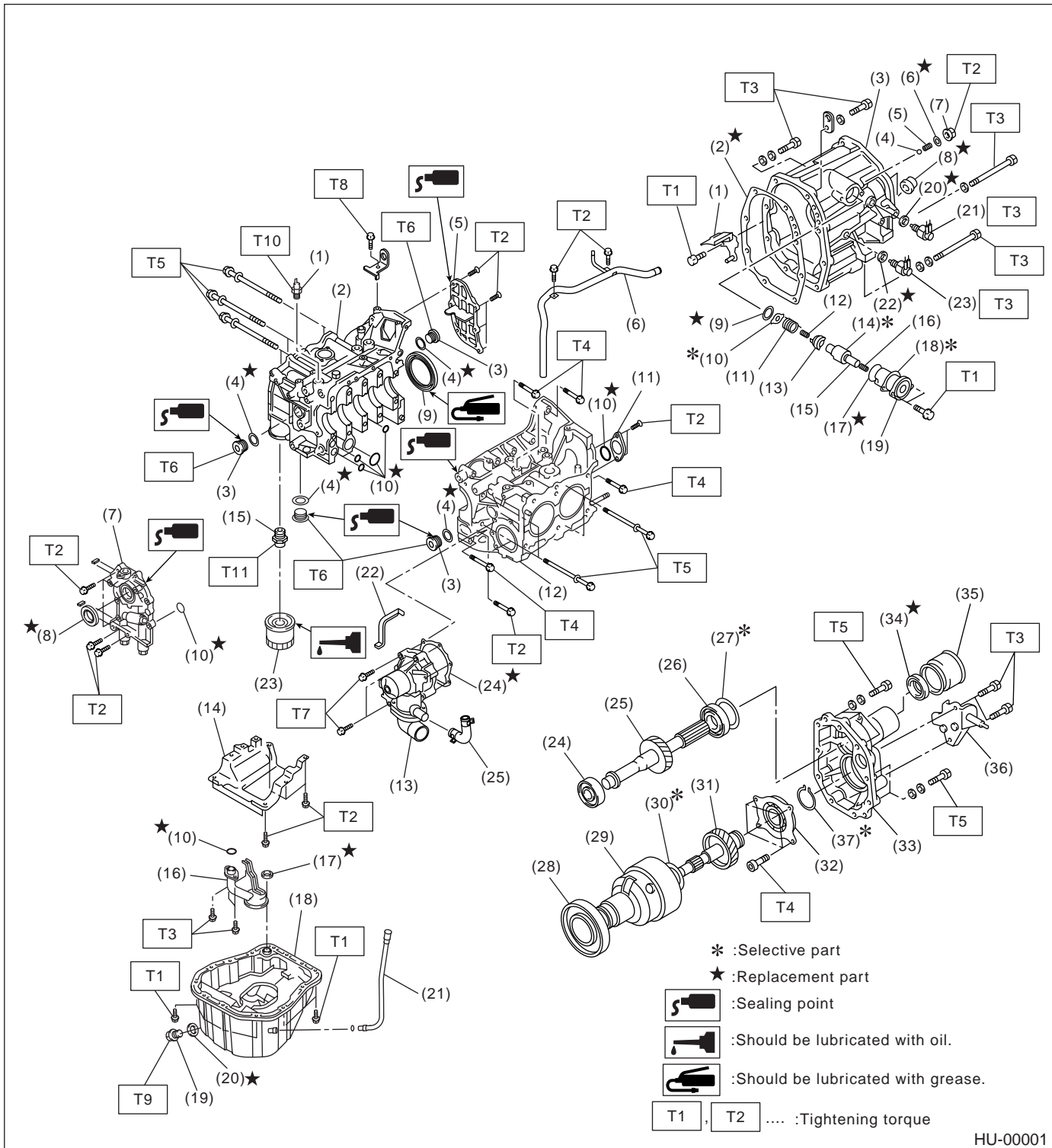

HOW TO USE THIS MANUALS

HOW TO USE THIS MANUALS

4. SPECIFICATIONS

If necessary, specifications are also included.

5. INSPECTION

Inspections are included to be carried out before and after maintenance.

6. MAINTENANCE

- Maintenance instructions for serviceable parts describes work area and detailed steps with illustration. It also describes the use of special tool, tightening torque, cautions for each procedure.
- If many serviceable parts are included in one service procedure, appropriate reference are provided for each part.

Example:

15.Main Shaft Assembly for Sin- ← (A)
gle-Range

A: REMOVAL ← (B)

1) Remove the manual transmission assembly from vehicle. <Ref. to MT-33, REMOVAL, Manual Transmission Assembly.> ← (C)

11) Tighten the lock nuts to the specified torque using ST1 and ST2.

NOTE: ← (D)
Secure the lock nuts in two Places after tightening.

ST2 499987003 SOCKET WRENCH
ST1 498937000 TRANSMISSION HOLDER ← (E) (F)

Tightening torque: ← (G)
118 N·m (12.0 kgf-m, 86.8 ft-lb)

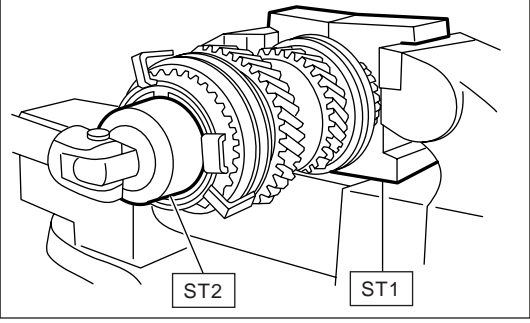

HU-00002

(A) Component

(B) Process

(C) Reference

(D) Caution

(E) Tool number of special tool

(F) Name of special tool

(G) Tightening torque

(H) Illustration

HOW TO USE THIS MANUALS

HOW TO USE THIS MANUALS

7. DIAGNOSIS

Tables showing a step-by-step process make it easy to conduct diagnosis.

8. SI UNITS

Measurements in these manuals are according to the SI units. Metric and yard/pound measurements are also included.

Example:

Tightening torque:

44 N·m (4.5 kgf-m, 33 ft-lb)

HOW TO USE THIS MANUALS

HOW TO USE THIS MANUALS

MEMO:

LEGACY

SPECIFICATIONS

1. Legacy

A: DIMENSIONS

| Model | | Sedan | | Station Wagon | | |
|------------------------|---------------|------------|---------------|-----------------------------|----------------------------|-----------|
| | | 2.5 L | | | | |
| | | AWD | | AWD | | |
| | | ALL | | BRIGHTON | L | 2.5 GT |
| Overall length | | mm (in) | 4,685 (184.4) | 4,760 (187.4) | | |
| Overall width | | mm (in) | 1,745 (68.7) | 1,745 (68.7) | | |
| Overall height | | mm (in) | 1,415 (55.7) | 1,435 (56.5) | | |
| Compartment | Leg room | Front Max. | mm (in) | 1,101 (43.3) | 1,101 (43.3) | |
| | | Rear Min. | mm (in) | 868 (34.2) | 871 (34.3) | |
| | Head room | Front | mm (in) | 987 (38.9), 967 (38.1)*1 | 1,020 (40.2), 977 (38.5)*1 | |
| | | Rear | mm (in) | 930 (36.6) | 994 (39.1), 945 (37.2)*1 | |
| | Shoulder room | Front | mm (in) | 1,368 (53.9) | 1,368 (53.9) | |
| | | Rear | mm (in) | 1,362 (53.6) | 1,362 (53.6) | |
| Wheelbase | | mm (in) | 2,650 (104.3) | 2,650 (104.3) | | |
| Tread | | Front | mm (in) | 1,460 (57.5) | 1,460 (57.5) | |
| | | Rear | mm (in) | 1,460 (57.5) | 1,455 (57.3) | |
| Minimum road clearance | | M.L.V.W. | mm (in) | 115 (4.5) | 120 (4.7) | 125 (4.9) |
| | | C.W. | mm (in) | 155 (6.1) | 160 (6.3) | |

*1: with sunroof

B: ENGINE

| Model | | Sedan/Station Wagon | |
|-------------------------------------|-------------------------|---|--|
| Engine type | | Horizontally opposed, liquid cooled, 4-cylinder, 4-stroke gasoline engine | |
| Valve arrangement | | Overhead camshaft type | |
| Bore × Stroke | mm (in) | 99.5 × 79.0 (3.917 × 3.110) | |
| Displacement | cm ³ (cu in) | 2,457 (149.9) | |
| Compression ratio | | 10.0 | |
| Firing order | | 1 — 3 — 2 — 4 | |
| Idle speed at Park/Neutral position | rpm | 650 (MT), 700 (AT) | |
| Maximum output | kW (HP)/rpm | 123 (165)/5,600 | |
| Maximum torque | N·m (kgf-m, ft-lb)/rpm | 226 (23.0, 166)/3,600 | |

C: ELECTRICAL

| Model | | Sedan/Station Wagon | |
|---------------------------------|-----------------------|--|----------------------------------|
| Ignition timing at idling speed | | BTDC/rpm | 10°±8°/650 (MT), 15°±8°/700 (AT) |
| Spark plug | Type and manufacturer | CHAMPION: RC10YC4 (Standard) NGK: BKR5E-11 NGK: BKR6E-11 | |
| Alternator | | 12V — 90A | |
| Battery | Reserve capacity | min | 90 (MT), 110 (AT) |
| | Cold cranking amperes | amp. | 430 (MT), 490 (AT) |

LEGACY

SPECIFICATIONS

D: TRANSMISSION

| Model | | Sedan/Station Wagon | |
|------------------------------|--------------------|---------------------|------------------|
| | | AWD | |
| Transmission type | | 5MT | 4AT |
| Clutch type | | DSPD | TCC |
| Gear ratio | 1st | 3.454 | 2.785*1, 3.027*2 |
| | 2nd | 2.062 | 1.545*1, 1.619*2 |
| | 3rd | 1.448 | 1.000 |
| | 4th | 1.088 | 0.694 |
| | 5th | 0.780 | — |
| | Reverse | 3.333 | 2.272 |
| Reduction gear (Front drive) | 1st reduction | Type of gear | — |
| | | Gear ratio | — |
| | Final reduction | Type of gear | Hypoid |
| | | Gear ratio | 3.900*1, 4.111*2 |
| Reduction gear (Rear drive) | Transfer reduction | Type of gear | Helical |
| | | Gear ratio | 1.000 |
| | Final reduction | Type of gear | Hypoid |
| | | Gear ratio | 3.900*1, 4.111*2 |

5MT: 5-forward speeds with synchromesh and 1-reverse – with center differential and viscous coupling

4AT: Electronically controlled fully-automatic, 4-forward speeds and 1-reverse – with hydraulically controlled transfer clutch

*1: L, BRIGHTON

*2: 2.5 GT, 2.5 GTLO

DSPD: Dry Single Plate Diaphragm

TCC: Torque Converter Clutch

E: STEERING

| | | |
|------------------------|-----------------|--|
| Type | Rack and Pinion | |
| Turns, lock to lock | 3.2 | |
| Minimum turning circle | m (ft) | Curb to curb: 11.6 (38.1), Wall to wall: 10.8 (35.4) |

F: SUSPENSION

| | |
|-------|---|
| Front | Macpherson strut type, Independent, Coil spring |
| Rear | Multi-link type, Independent, Coil spring |

G: BRAKE

| | |
|----------------------|---|
| Model | With ABS |
| Service brake system | Dual circuit hydraulic with vacuum suspended power unit |
| Front | Ventilated disc brake |
| Rear | Disc brake |
| Parking brake | Mechanical on rear brakes |

H: TIRE

| Model | 15-inch wheel | | 16-inch wheel |
|-------|-------------------------------|----------------|----------------|
| | Size | P195/60R15 87H | P205/60R15 90H |
| Type | Steel belted radial, Tubeless | | |

LEGACY

SPECIFICATIONS

I: CAPACITY

| Model | | AWD | |
|--------------------------------|---------------------|---------------------------------|-----------------------------------|
| | | 5MT | 4AT |
| Fuel tank | ℓ (US gal, Imp gal) | 64 (16.9, 14.1) | |
| Engine oil (Replacement) | ℓ (US qt, Imp qt) | Approx. 4.0 (4.2, 3.5) | |
| Transmission gear oil | ℓ (US qt, Imp qt) | 3.5 (3.7, 3.1) | — |
| Automatic transmission fluid | ℓ (US qt, Imp qt) | — | 9.3 – 9.6 (9.8 – 10.1, 8.2 – 8.4) |
| AT differential gear oil | ℓ (US qt, Imp qt) | — | 1.1 – 1.3 (1.2 – 1.4, 1.0 – 1.1) |
| AWD rear differential gear oil | ℓ (US qt, Imp qt) | 0.8 (0.8, 0.7), 0.9 (0.9, 0.8)* | |
| Power steering fluid | ℓ (US qt, Imp qt) | 0.7 (0.7, 0.6) | |
| Engine coolant | ℓ (US qt, Imp qt) | 6.8 (7.2, 6.0) | 6.7 (7.1, 5.9) |

*: L, BRIGHTON

J: WEIGHT

1. U.S. SPEC. VEHICLE

| Model | Sedan | | | | | |
|-------------------------------|-------|---------|---------------|---------------|---------------|---------------|
| | 2.5 L | | | | | |
| | AWD | | | | | |
| | L | | 2.5 GT | | | |
| | | 5MT | 4AT | 5MT | 4AT-SS | |
| Curb weight (C.W.) | Front | kg (lb) | 812 (1,790) | 839 (1,850) | 844 (1,860) | 866 (1,910) |
| | Rear | kg (lb) | 651 (1,435) | 653 (1,440) | 683 (1,505) | 685 (1,510) |
| | Total | kg (lb) | 1,463 (3,225) | 1,492 (3,290) | 1,527 (3,365) | 1,551 (3,420) |
| Gross vehicle weight (G.V.W.) | Front | kg (lb) | 1,007 (2,220) | | | |
| | Rear | kg (lb) | 989 (2,180) | | | |
| | Total | kg (lb) | 1,996 (4,400) | | | |

| Model | Station Wagon | | | | | |
|-------------------------------|---------------|---------|---------------|---------------|---------------|---------------|
| | 2.5 L | | | | | |
| | AWD | | | | | |
| | L | | 2.5 GT | | | |
| | | 5MT | 4AT | 5MT | 4AT-SS | |
| Curb weight (C.W.) | Front | kg (lb) | 812 (1,790) | 841 (1,855) | 844 (1,860) | 869 (1,915) |
| | Rear | kg (lb) | 701 (1,545) | 701 (1,545) | 730 (1,610) | 735 (1,620) |
| | Total | kg (lb) | 1,513 (3,335) | 1,542 (3,400) | 1,574 (3,470) | 1,604 (3,535) |
| Gross vehicle weight (G.V.W.) | Front | kg (lb) | 1,002 (2,210) | | | |
| | Rear | kg (lb) | 1,064 (2,345) | | | |
| | Total | kg (lb) | 2,066 (4,555) | | | |

LEGACY

SPECIFICATIONS

2. CANADA SPEC. VEHICLE

| | | | | | | | | |
|-------------------------------|-------|---------|---------------|-----|---------------|--------|---------------|--|
| Model | | Sedan | | | | | | |
| | | 2.5 L | | | | | | |
| | | AWD | | | | | | |
| | | L | | | 2.5 GT | | | |
| | | 4AT | | 5MT | | 4AT-SS | | |
| Curb weight (C.W.) | Front | kg (lb) | 839 (1,850) | | 844 (1,860) | | 866 (1,910) | |
| | Rear | kg (lb) | 653 (1,440) | | 683 (1,505) | | 685 (1,510) | |
| | Total | kg (lb) | 1,492 (3,290) | | 1,527 (3,365) | | 1,551 (3,420) | |
| Gross vehicle weight (G.V.W.) | Front | kg (lb) | 1,007 (2,220) | | | | | |
| | Rear | kg (lb) | 989 (2,180) | | | | | |
| | Total | kg (lb) | 1,996 (4,400) | | | | | |

| | | | | | | | | |
|-------------------------------|-------|----------|---------------|--|--------|---------------|--|--|
| Model | | Sedan | | | | | | |
| | | 2.5 L | | | | | | |
| | | AWD | | | | | | |
| | | 2.5 GTLO | | | | | | |
| | | 5MT | | | 4AT-SS | | | |
| Curb weight (C.W.) | Front | kg (lb) | 839 (1,850) | | | 862 (1,900) | | |
| | Rear | kg (lb) | 678 (1,495) | | | 680 (1,500) | | |
| | Total | kg (lb) | 1,517 (3,345) | | | 1,542 (3,400) | | |
| Gross vehicle weight (G.V.W.) | Front | kg (lb) | 1,007 (2,220) | | | | | |
| | Rear | kg (lb) | 989 (2,180) | | | | | |
| | Total | kg (lb) | 1,996 (4,400) | | | | | |

| | | | | | | | |
|-------------------------------|-------|---------------|---------------|---------------|---------------|---------------|---------------|
| Model | | Station Wagon | | | | | |
| | | 2.5 L | | | | | |
| | | AWD | | | | | |
| | | BRIGHTON | | L | | 2.5 GT | |
| | | 5MT | 4AT | 5MT | 4AT | 4AT-SS | |
| Curb weight (C.W.) | Front | kg (lb) | 807 (1,780) | 832 (1,835) | 812 (1,790) | 841 (1,855) | 869 (1,915) |
| | Rear | kg (lb) | 678 (1,495) | 683 (1,505) | 701 (1,545) | 701 (1,545) | 735 (1,620) |
| | Total | kg (lb) | 1,485 (3,275) | 1,515 (3,340) | 1,513 (3,335) | 1,542 (3,400) | 1,604 (3,535) |
| Gross vehicle weight (G.V.W.) | Front | kg (lb) | 962 (2,120) | | 1,002 (2,210) | | |
| | Rear | kg (lb) | 1,016 (2,240) | | 1,064 (2,345) | | |
| | Total | kg (lb) | 1,978 (4,360) | | 2,066 (4,555) | | |

3. TIWAN SPEC. VEHICLE

| | | | | | | | | |
|-------------------------------|-------|---------|---------------|--------|---------------|---------------|---------------|--|
| Model | | Sedan | | | | Station Wagon | | |
| | | 2.5 L | | | | | | |
| | | AWD | | | | | | |
| | | L | | 2.5 GT | | L | | |
| | | 4AT | | 4AT-SS | | 4AT | | |
| Curb weight (C.W.) | Front | kg (lb) | 839 (1,850) | | 866 (1,910) | | 841 (1,855) | |
| | Rear | kg (lb) | 653 (1,440) | | 685 (1,510) | | 701 (1,545) | |
| | Total | kg (lb) | 1,492 (3,290) | | 1,551 (3,420) | | 1,542 (3,400) | |
| Gross vehicle weight (G.V.W.) | Front | kg (lb) | 1,007 (2,220) | | | | 1,002 (2,210) | |
| | Rear | kg (lb) | 989 (2,180) | | | | 1,064 (2,345) | |
| | Total | kg (lb) | 1,996 (4,400) | | | | 2,066 (4,555) | |

OUTBACK

SPECIFICATIONS

2. OUTBACK

A: DIMENSIONS

| Model | | | | Sedan | | Wagon | |
|------------------------|---------------|------------|---------|--------------------------|----------------------------|---------------|-----|
| | | | | AWD | | AWD | |
| | | | | 4AT | | 5MT | 4AT |
| Overall length | | | | mm (in) | 4,685 (184.4) | 4,760 (187.4) | |
| Overall width | | | | mm (in) | 1,745 (68.7) | 1,745 (68.7) | |
| Overall height | | | | mm (in) | 1,480 (58.3) | 1,580 (62.2) | |
| Compartment | Leg room | Front Max. | mm (in) | 1,101 (43.3) | 1,101 (43.3) | | |
| | | Rear Min. | mm (in) | 868 (34.2) | 871 (34.3) | | |
| | Head room | Front | mm (in) | 987 (38.9), 967 (38.1)*1 | 1,020 (40.2), 977 (38.5)*1 | | |
| | | Rear | mm (in) | 930 (36.6) | 994 (39.1), 945 (37.2)*1 | | |
| | Shoulder room | Front | mm (in) | 1,368 (53.9) | 1,368 (53.9) | | |
| | | Rear | mm (in) | 1,362 (53.6) | 1,362 (53.6) | | |
| Wheelbase | | | | mm (in) | 2,650 (104.3) | 2,650 (104.3) | |
| Tread | | Front | mm (in) | 1,470 (57.9) | 1,470 (57.9) | | |
| | | Rear | mm (in) | 1,465 (57.7) | 1,465 (57.7) | | |
| Minimum road clearance | | M.L.V.W. | mm (in) | 150 (5.9) | 150 (5.9) | | |
| | | C.W. | mm (in) | 185 (7.3) | 185 (7.3) | | |

*1: With sunroof

B: ENGINE

| Model | | | Sedan/Wagon | |
|---|--|--|---|---|
| | | | 2.5 L | 3.0 L |
| Engine type | | | Horizontally opposed, liquid cooled, 4-cylinder, 4-stroke gasoline engine | Horizontally opposed, liquid cooled, 6-cylinder, 4-stroke gasoline engine |
| Valve arrangement | | | Overhead camshaft type | Double overhead camshaft type |
| Bore × Stroke | | | mm (in) 99.5 × 79.0 (3.917 × 3.110) | 89.2 × 80.0 (3.512 × 3.150) |
| Displacement | | | cm ³ (cu in) 2,457 (149.9) | 3,000 (183.06) |
| Compression ratio | | | 10.0 | 10.7 |
| Firing order | | | 1 — 3 — 2 — 4 | 1 — 6 — 3 — 2 — 5 — 4 |
| Idle speed at Park/ Neutral position | | | rpm 650 (MT), 700 (AT) | 600 |
| Maximum output | | | kW (HP)/rpm 123 (165)/5,600 | 158 (212)/6,000 |
| Maximum torque | | | N·m (kgf·m, ft·lb)/rpm 226 (23.0, 166)/3,600 | 282 (28.8, 208)/4,400 |

C: ELECTRICAL

| Model | | | Sedan/Wagon | |
|---------------------------------|-----------------------|------|--|----------------|
| | | | 2.5 L | 3.0 L |
| Ignition timing at idling speed | | | BTDC/rpm 10°±8°/650 (MT), 15°±8°/700 (AT) | 10°±8°/600 |
| Spark plug | Type and manufacturer | | CHAMPION: RC10YC4 (Standard) NGK: BKR5E-11 NGK: BKR6E-11 | NGK: PLFR6A-11 |
| Alternator | | | 12V — 90A | 12V — 100A |
| Battery | Reserve capacity | min | 90 (MT), 110 (AT) | 110 |
| | Cold cranking amperes | amp. | 430 (MT), 490 (AT) | 490 |

OUTBACK

SPECIFICATIONS

D: TRANSMISSION

| | | | | | |
|------------------------------|--------------------|--------------|---------|-------|-------|
| Model | | Sedan/Wagon | | | |
| | | 2.5 L | | 3.0 L | |
| | | AWD | | | |
| Transmission type | | 5MT | 4AT | | |
| Clutch type | | DSPD | TCC | | |
| Gear ratio | 1st | 3.454 | 3.027 | 2.785 | |
| | 2nd | 2.062 | 1.619 | 1.545 | |
| | 3rd | 1.448 | 1.000 | | |
| | 4th | 1.088 | 0.694 | | |
| | 5th | 0.871 | — | | |
| | Reverse | 3.333 | 2.272 | | |
| Reduction gear (Front drive) | 1st reduction | Type of gear | — | | |
| | | Gear ratio | — | | |
| | Final reduction | Type of gear | Hypoid | | |
| | | Gear ratio | 4.111 | 4.444 | 4.111 |
| Reduction gear (Rear drive) | Transfer reduction | Type of gear | Helical | | |
| | | Gear ratio | 1.000 | | |
| | Final reduction | Type of gear | Hypoid | | |
| | | Gear ratio | 4.111 | 4.444 | 4.111 |

5MT: 5-forward speed with synchromesh and 1-reverse – with center differential and viscous coupling

4AT: Electronically controlled fully-automatic, 4-forward speeds and 1-reverse – with hydraulically controlled transfer clutch

DSPD: Dry Single Plate Diaphragm

TCC: Torque Converter Clutch

E: STEERING

| | | |
|------------------------|-----------------|--|
| Type | Rack and Pinion | |
| Turns, lock to lock | 3.4 | |
| Minimum turning circle | m (ft) | Curb to curb: 12.0 (39.4), Wall to wall: 11.2 (36.7) |

F: SUSPENSION

| | |
|-------|---|
| Front | Macpherson strut type, Independent, Coil spring |
| Rear | Multi-link type, Independent, Coil spring |

G: BRAKE

| | |
|----------------------|---|
| Model | With ABS |
| Service brake system | Dual circuit hydraulic with vacuum suspended power unit |
| Front | Ventilated disc brake |
| Rear | Disc brakes |
| Parking brake | Mechanical on rear brakes |

H: TIRE

| | | |
|-------|-------------------------------|----------------|
| Model | 16-inch wheel | |
| Size | P215/60R16* | P225/60R16 97H |
| Type | Steel belted radial, Tubeless | |

*: Recommended winter (snow) tire size.

OUTBACK

SPECIFICATIONS

I: CAPACITY

| Model | ℓ (US gal, Imp gal) | 2.5 L | | 3.0 L | |
|--------------------------------|---------------------|------------------------|----------------|-----------------------------------|--|
| | | AWD | | | |
| | | 5MT | | 4AT | |
| Fuel tank | | 64 (16.9, 14.1) | | | |
| Engine oil (Replacement) | | Approx. 4.0 (4.2, 3.5) | | Approx. 5.6 (5.9, 4.9) | |
| Transmission gear oil | | 3.5 (3.7, 3.1) | | — | |
| Automatic transmission fluid | | — | | 9.3 – 9.6 (9.8 – 10.1, 8.2 – 8.4) | |
| AT differential gear oil | | — | | 1.1 – 1.3 (1.2 – 1.4, 1.0 – 1.1) | |
| AWD rear differential gear oil | | 0.8 (0.8, 0.7) | | | |
| Power steering fluid | | 0.7 (0.7, 0.6) | | | |
| Engine coolant | | 6.8 (7.2, 6.0) | 6.7 (7.1, 5.9) | 7.9 (8.4, 7.0) | |

J: WEIGHT

1. U.S. SPEC. VEHICLE

| Model | | Sedan | | | |
|-------------------------------|-------|---------|---------------|---------------|--|
| | | 2.5 L | | 3.0 L | |
| | | AWD | | | |
| | | 4AT | | 4AT*1 | |
| Curb weight (C.W.) | Front | kg (lb) | 894 (1,970) | 943 (2,080) | |
| | Rear | kg (lb) | 692 (1,525) | 694 (1,530) | |
| | Total | kg (lb) | 1,586 (3,495) | 1,637 (3,610) | |
| Gross vehicle weight (G.V.W.) | Front | kg (lb) | 1,007 (2,220) | 1,061 (2,340) | |
| | Rear | kg (lb) | 989 (2,180) | 989 (2,180) | |
| | Total | kg (lb) | 1,996 (4,400) | 2,050 (4,520) | |

| Model | | Wagon | | | | |
|-------------------------------|-------|--------------|---------------|---------------|---------------|---------------|
| | | 2.5 L | | | | |
| | | Cold weather | | LTD | | |
| | | 5MT | | 4AT | | |
| Curb weight (C.W.) | Front | kg (lb) | 844 (1,860) | 869 (1,915) | 857 (1,890) | 882 (1,945) |
| | Rear | kg (lb) | 712 (1,570) | 717 (1,580) | 735 (1,620) | 739 (1,630) |
| | Total | kg (lb) | 1,556 (3,430) | 1,586 (3,495) | 1,592 (3,510) | 1,621 (3,575) |
| Gross vehicle weight (G.V.W.) | Front | kg (lb) | 1,002 (2,210) | | | |
| | Rear | kg (lb) | 1,064 (2,345) | | | |
| | Total | kg (lb) | 2,066 (4,555) | | | |

| Model | | Wagon | | | |
|-------------------------------|-------|---------|---------------|---------------|---------------|
| | | 2.5 L | | 3.0 L | |
| | | OTHERS | | | |
| | | 5MT | | 4AT | |
| Curb weight (C.W.) | Front | kg (lb) | 841 (1,855) | 866 (1,910) | 943 (2,080) |
| | Rear | kg (lb) | 712 (1,570) | 716 (1,580) | 741 (1,635) |
| | Total | kg (lb) | 1,553 (3,425) | 1,582 (3,490) | 1,684 (3,715) |
| Gross vehicle weight (G.V.W.) | Front | kg (lb) | 1,002 (2,210) | | 1,061 (2,340) |
| | Rear | kg (lb) | 1,064 (2,345) | | 1,070 (2,360) |
| | Total | kg (lb) | 2,066 (4,555) | | 2,131 (4,700) |

*1: Excludes the weights of audio, VDC

OUTBACK

SPECIFICATIONS

2. CANADA SPEC. VEHICLE

| Model | | Sedan | | |
|-------------------------------|-------|---------|---------------|---------------|
| | | 2.5 L | 3.0 L | |
| | | AWD | | |
| | | 4AT | 4AT*1 | |
| Curb weight (C.W.) | Front | kg (lb) | 894 (1,970) | 943 (2,080) |
| | Rear | kg (lb) | 692 (1,525) | 694 (1,530) |
| | Total | kg (lb) | 1,586 (3,495) | 1,637 (3,610) |
| Gross vehicle weight (G.V.W.) | Front | kg (lb) | 1,007 (2,220) | 1,061 (2,340) |
| | Rear | kg (lb) | 989 (2,180) | 989 (2,180) |
| | Total | kg (lb) | 1,996 (4,400) | 2,050 (4,520) |

| Model | | Wagon | | | | |
|-------------------------------|-------|--------------|---------------|---------------|---------------|---------------|
| | | 2.5 L | | 3.0 L | | |
| | | Cold Weather | LTD | ALL | | |
| | | 5MT | 4AT | 4AT*1 | | |
| Curb weight (C.W.) | Front | kg (lb) | 844 (1,860) | 869 (1,915) | 882 (1,945) | 943 (2,080) |
| | Rear | kg (lb) | 712 (1,570) | 717 (1,580) | 739 (1,630) | 741 (1,635) |
| | Total | kg (lb) | 1,556 (3,430) | 1,586 (3,495) | 1,621 (3,575) | 1,684 (3,715) |
| Gross vehicle weight (G.V.W.) | Front | kg (lb) | 1,002 (2,210) | | 1,061 (2,340) | |
| | Rear | kg (lb) | 1,064 (2,345) | | 1,070 (2,360) | |
| | Total | kg (lb) | 2,066 (4,555) | | 2,131 (4,700) | |

*1: Excludes the weights of audio, VDC

3. TAIWAN SPEC. VEHICLE

| Model | | Wagon | |
|-------------------------------|-------|---------|---------------|
| | | 2.5 L | |
| | | AWD | |
| | | 4AT | |
| Curb weight (C.W.) | Front | kg (lb) | 882 (1,945) |
| | Rear | kg (lb) | 739 (1,630) |
| | Total | kg (lb) | 1,621 (3,575) |
| Gross vehicle weight (G.V.W.) | Front | kg (lb) | 1,002 (2,210) |
| | Rear | kg (lb) | 1,064 (2,345) |
| | Total | kg (lb) | 2,066 (4,555) |

4. CHILE SPEC. VEHICLE

| Model | | Sedan | Wagon | |
|-------------------------------|-------|---------|---------------|---------------|
| | | 3.0 L | | |
| | | AWD | | |
| | | 4AT | | |
| Curb weight (C.W.) | Front | kg (lb) | 950 (2,095) | 950 (2,095) |
| | Rear | kg (lb) | 694 (1,530) | 741 (1,635) |
| | Total | kg (lb) | 1,644 (3,625) | 1,691 (3,730) |
| Gross vehicle weight (G.V.W.) | Front | kg (lb) | 1,061 (2,340) | 1,061 (2,340) |
| | Rear | kg (lb) | 989 (2,180) | 1,070 (2,360) |
| | Total | kg (lb) | 2,050 (4,520) | 2,131 (4,700) |

OUTBACK

SPECIFICATIONS

MEMO:

SPC-10

PRECAUTION

PRECAUTION

1. Precaution

A: PRECAUTION

Please clearly understand and adhere to the following general precautions. They must be strictly followed to avoid minor or serious injury to the person doing the work or people in the area.

1. ABS

Handle the ABS as a total system. Do not disassemble or attempt to repair individual parts. Doing so could prevent the ABS system from operating when needed or cause it to operate incorrectly and result in injury.

2. BRAKE FLUID

If brake fluid gets in your eyes or on your skin, do the following:

- Wash out your eyes and seek immediate medical attention.
- Wash your skin with soap and then rinse thoroughly with water.

3. ELECTRIC FAN

The electric fan may rotate without warning, even when the engine is not on. Do not place your hand, cloth, tools, or other items near the fan at any time.

4. ROAD TESTS

Always conduct road tests in accordance with traffic rules and regulations to avoid bodily injury and interrupting traffic.

5. AIRBAG

To prevent bodily injury from unexpected deployment of airbags and unnecessary maintenance, follow the instructions in this manual when performing maintenance on airbag components or nearby, and airbag wiring harnesses or nearby.

To prevent unexpected deployment, perform one of the steps below and then wait at least 20 seconds to discharge electricity before beginning work.

- Step 1: Turn the ignition switch OFF.
- Step 2: Remove the negative battery terminal.

6. AIRBAG DISPOSAL

To prevent bodily injury from unexpected airbag deployment, do not dispose airbag modules in the same way as other refuse. Follow all government regulations concerning disposal of refuse.

7. AIRBAG MODULE

Adhere to the following when handling and storing the airbag module to prevent bodily injury from unexpected deployment:

- Do not hold harnesses or connectors to carry the module.
- Do not face the bag in the direction that it opens towards yourself or other people.
- Do not face the bag in the direction that it opens towards the floor or walls.

8. AIRBAG SPECIAL TOOLS

To prevent unexpected deployment, only use special tools.

9. WINDOW

Always wear safety glasses when working around any glass to prevent glass fragments from damaging your eyes.

10. WINDOW ADHESIVE

Always use the specified urethane adhesive when attaching glass to prevent it from coming loose and falling, resulting in accidents and injury.

NOTE

NOTE

1. Note

A: NOTE

This is information that can improve efficiency of maintenance and assure sound work.

1. FASTENER NOTICE

Fasteners are used to prevent parts from damage and dislocation due to looseness. Fasteners must be tightened to the specified torque.

Do not apply paint, lubricant, rust retardant, or other substances to the surface around bolts, fasteners, etc. Doing so will make it difficult to obtain the correct torque and result in looseness and other problems.

2. STATIC ELECTRICITY DAMAGE

Do not touch the ECM, connectors, logic boards, and other such parts when there is a risk of static electricity. Always use a static electricity prevention cord or touch grounded metal before conducting work.

3. IGNITION OFF BATTERY

When removing the battery cables, always be sure to turn the ignition off to prevent electrical damage to the ECM from rush current.

4. SERVICE PARTS

Use authentic service parts for maximum performance and maintenance, when conducting repairs. Subaru/FHI will not be responsible for poor performance resulting from the use of parts not specified by a genuine dealer.

5. LIFTS AND JACKS

When using a lift or jack-ridged rack to raise a vehicle, always follow instructions concerning jack-up points and weight limits to prevent the vehicle from falling, which could result in injury. Be especially careful to make sure the vehicle is balanced before raising it.

• Support locations

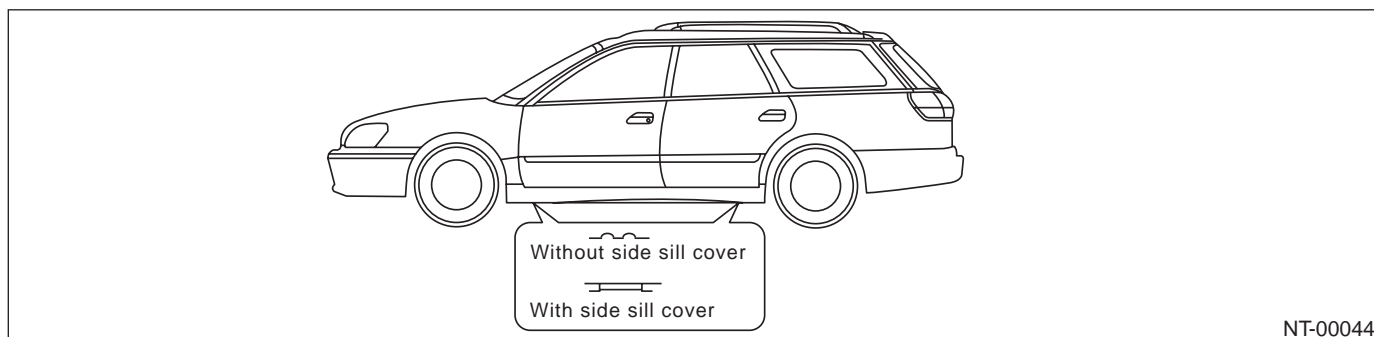

NOTE

NOTE

- Pantograph jack

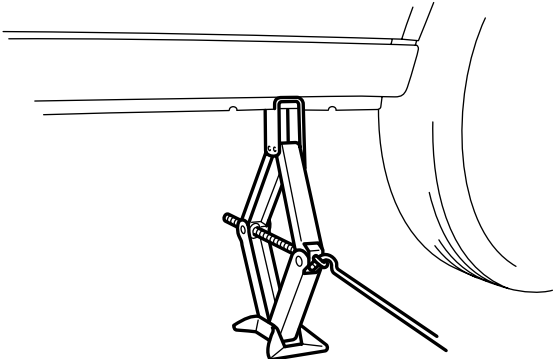
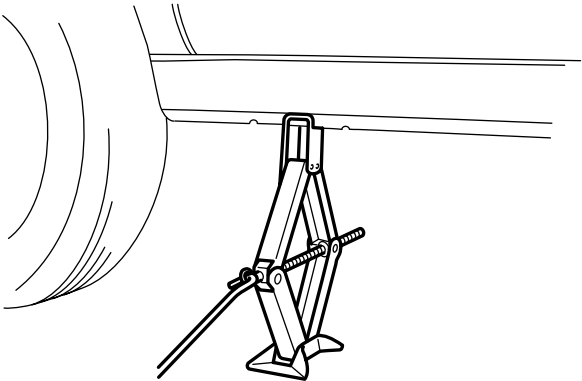
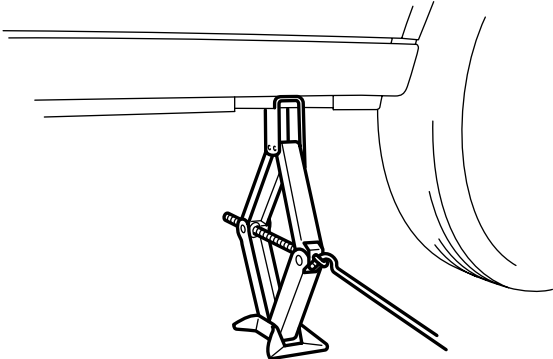
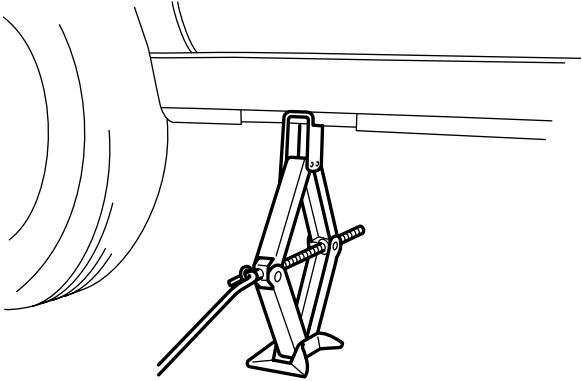

NT-00045

NOTE

NOTE

• **Lift**

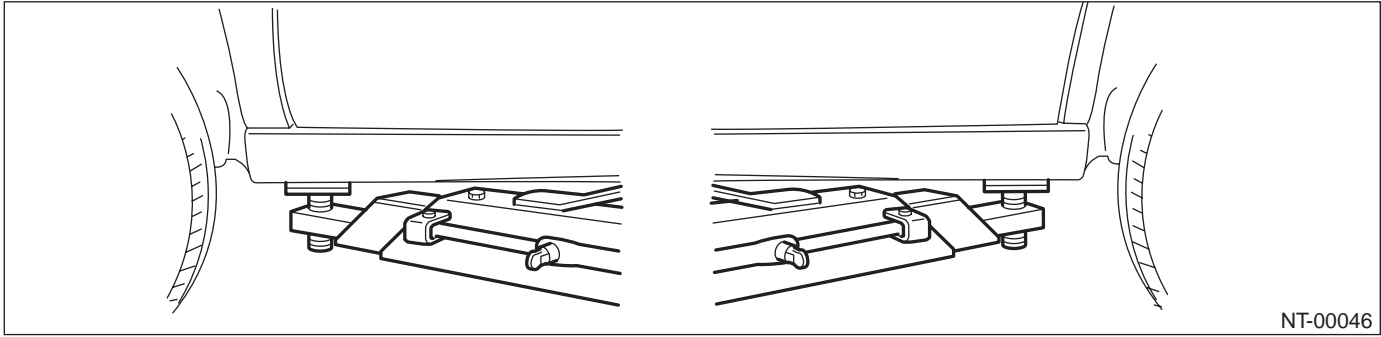

• **Safety stand**

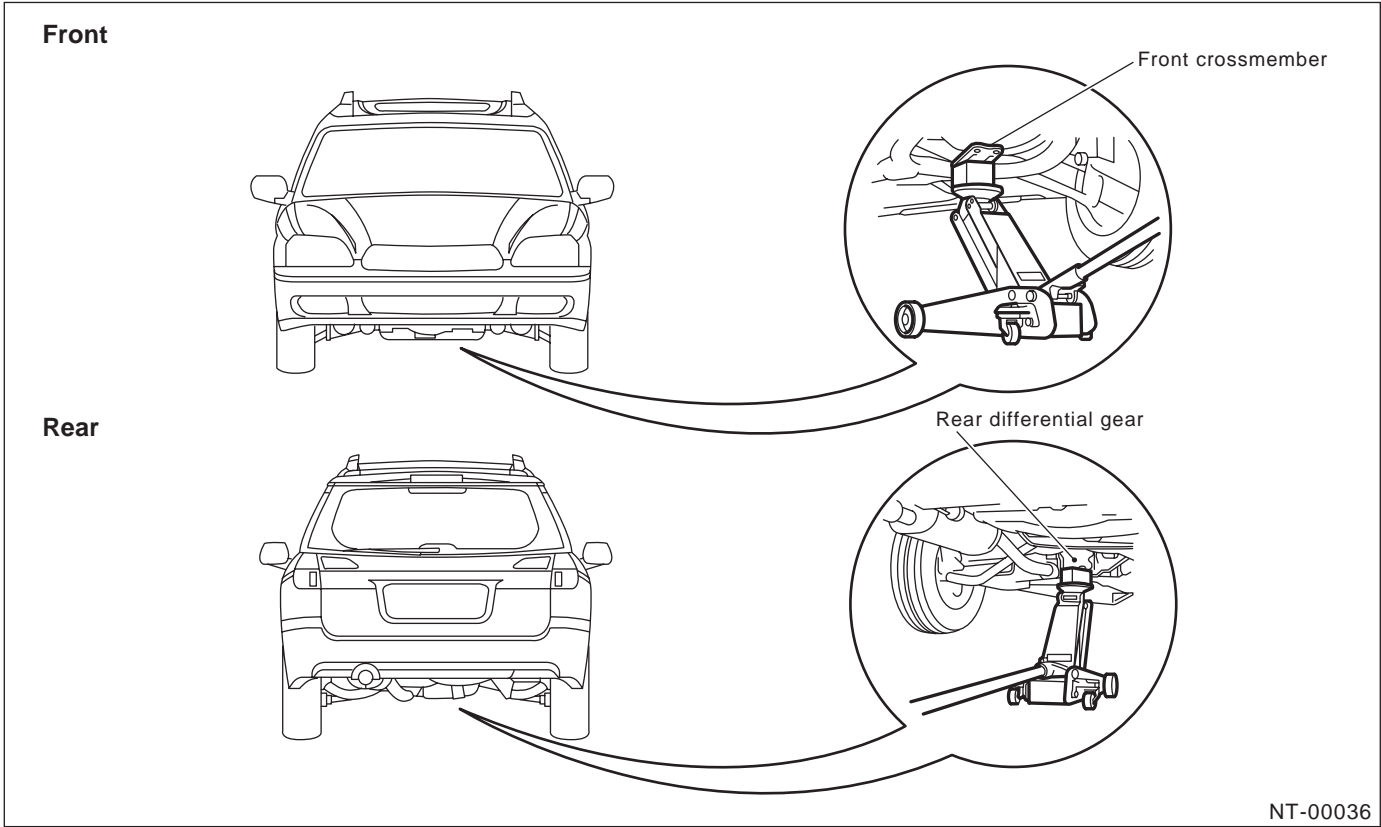
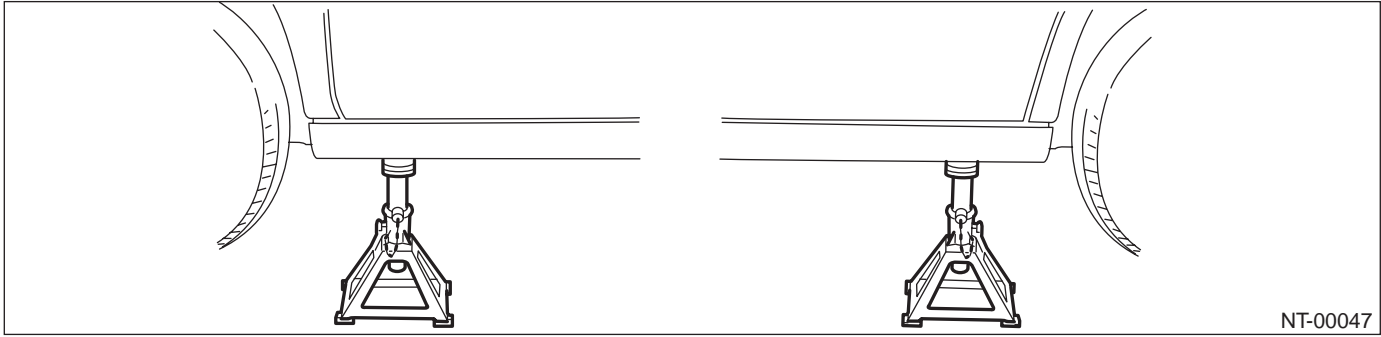

NOTE

NOTE

6. TIE DOWNS

Tie-downs are used when transporting vehicles and when using the chassis dynamo.

• Tie-down points

Attach tie-downs only to the specified points on the vehicle.

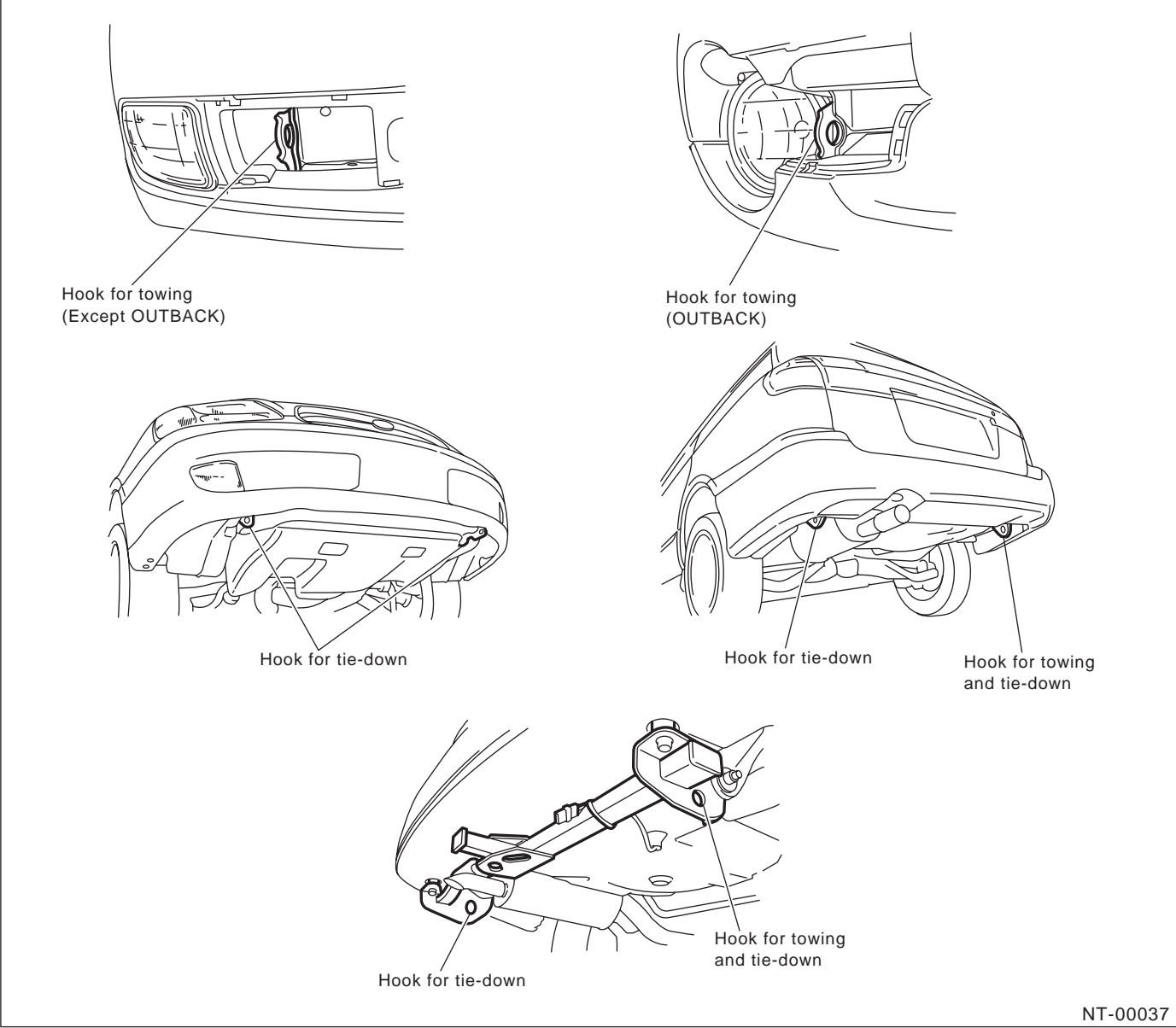

NOTE

NOTE

• Chain direction at tie-down condition

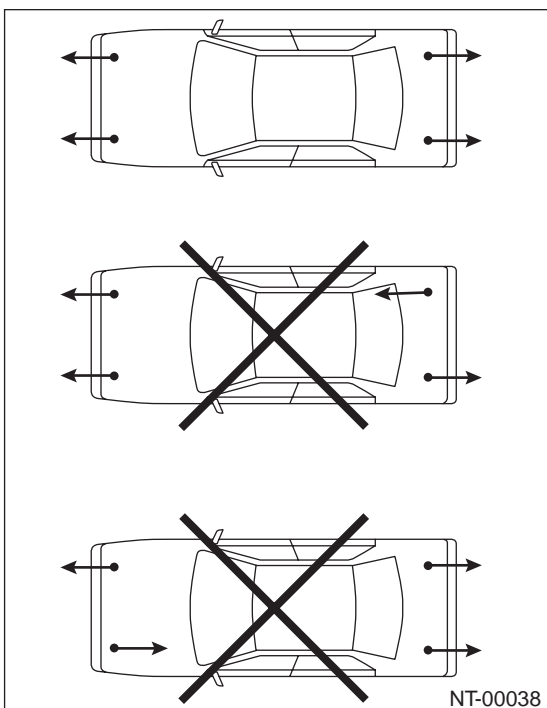

• Chain pulling range at tie-down condition

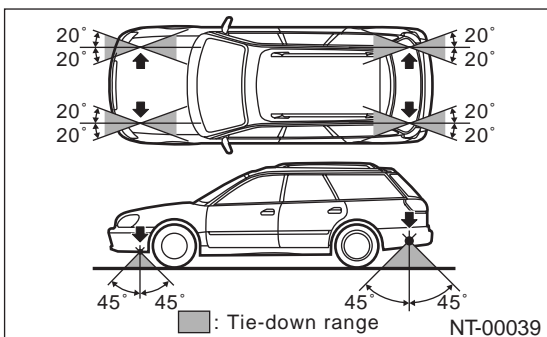

• Vehicle sinking volume at tie-down condition

Measure distance L between tire highest point to arch highest point before tie-down and after tie-down. Difference of measurement value (drop height) shall be within 50.8 mm (2.00 in). Make sure to fix a vehicle securely.

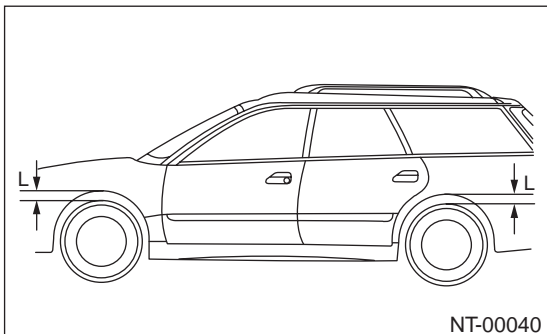

7. TOWING

Avoid towing vehicles except when the vehicle cannot be driven. For vehicles with AWD, AT or VTD, use a loader instead of towing. When towing other vehicles, to prevent excessive weight from damaging the hook or vehicle:

- Do not tow other vehicles with a front towing hook.
- Make sure the vehicle towing is heavier than the vehicle being towed.

NOTE

NOTE

8. FRONT HOOD STAY INSTALLATION

- At the check and general maintenance

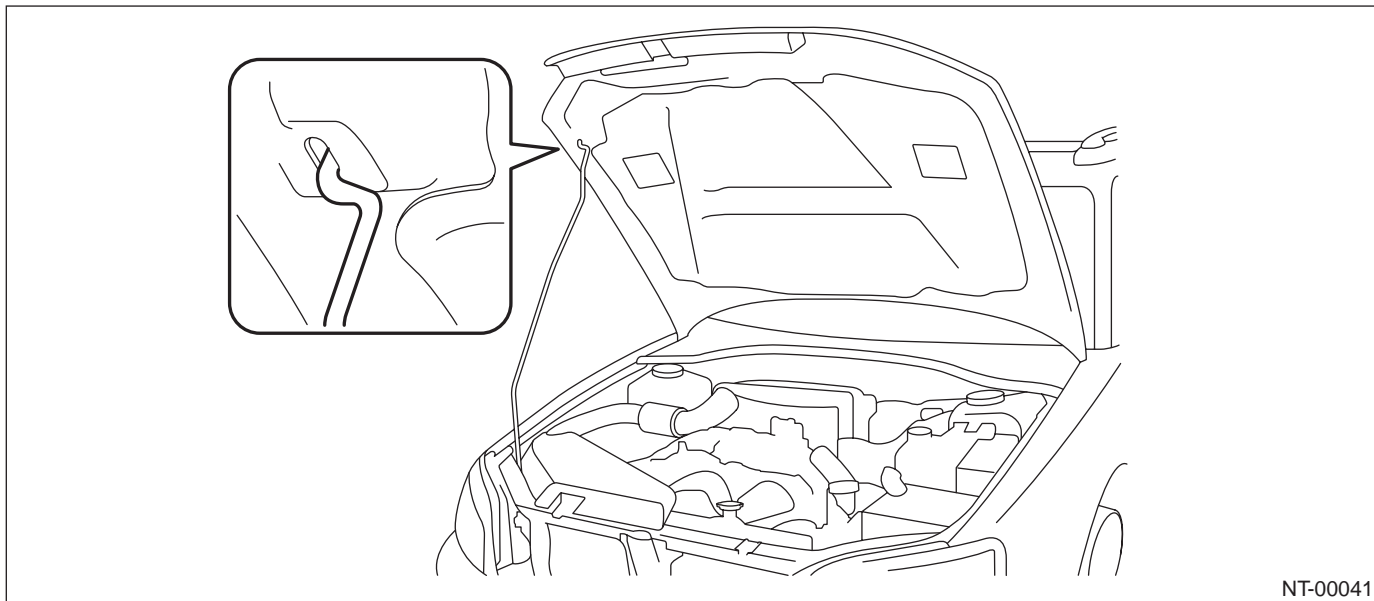

- When wider hood opening is necessary

Set stay into the hole of hood inner as shown in the figure below.

NOTE:

Before setting the hood in this position, remove the windshield washer hose attaching clip from the hood.

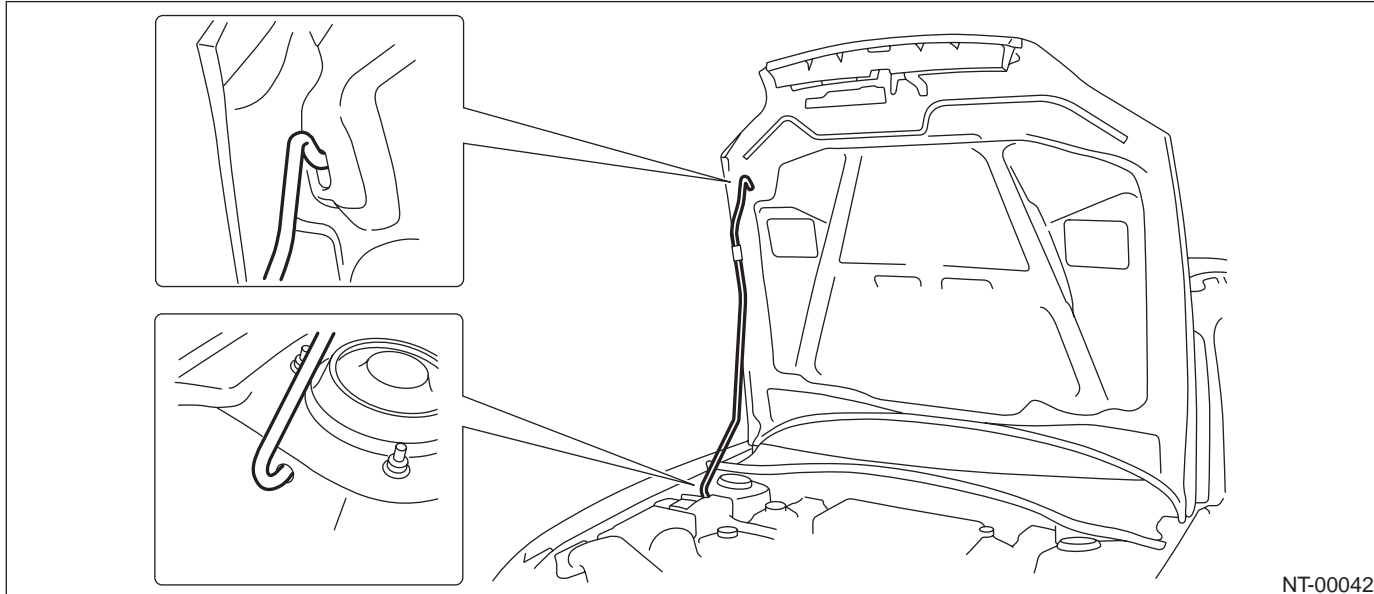

9. TRAINING

For information about training, contact a dealer or agent.

10. GENERAL SCAN TOOL

Using general scan tools will greatly improve efficiency of repairing engine electronic controls. The Subaru Select Monitor can be used to diagnose the engine and also the ABS, the air conditioner, and other parts.

NOTE

NOTE

MEMO:

IDENTIFICATION

IDENTIFICATION

1. Identification

A: IDENTIFICATION

1. IDENTIFICATION NUMBER AND LABEL LOCATIONS

The VIN (Vehicle Identification Numbers) is used to classify the vehicle.

Positioning of the plate label for identification

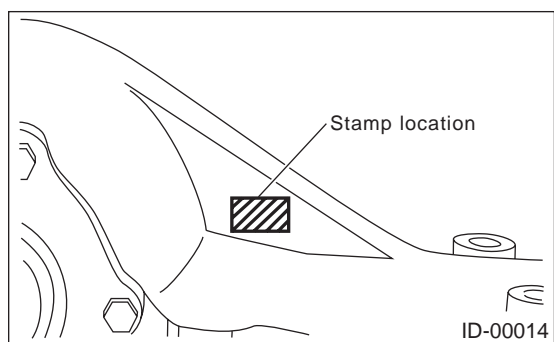
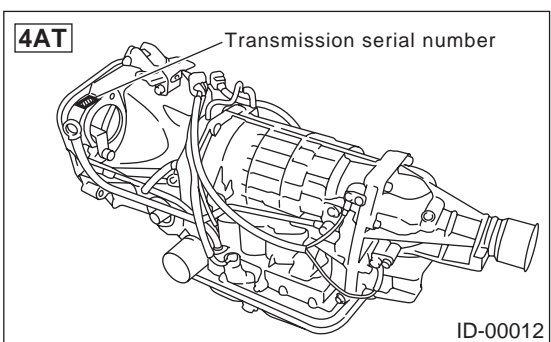
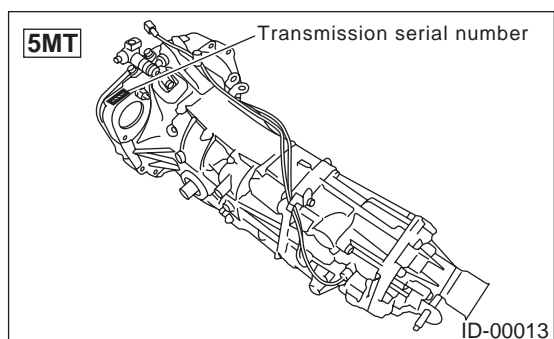
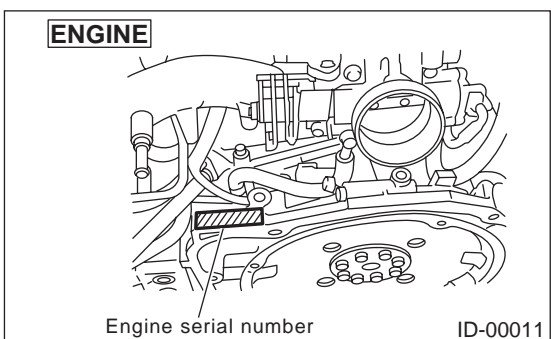
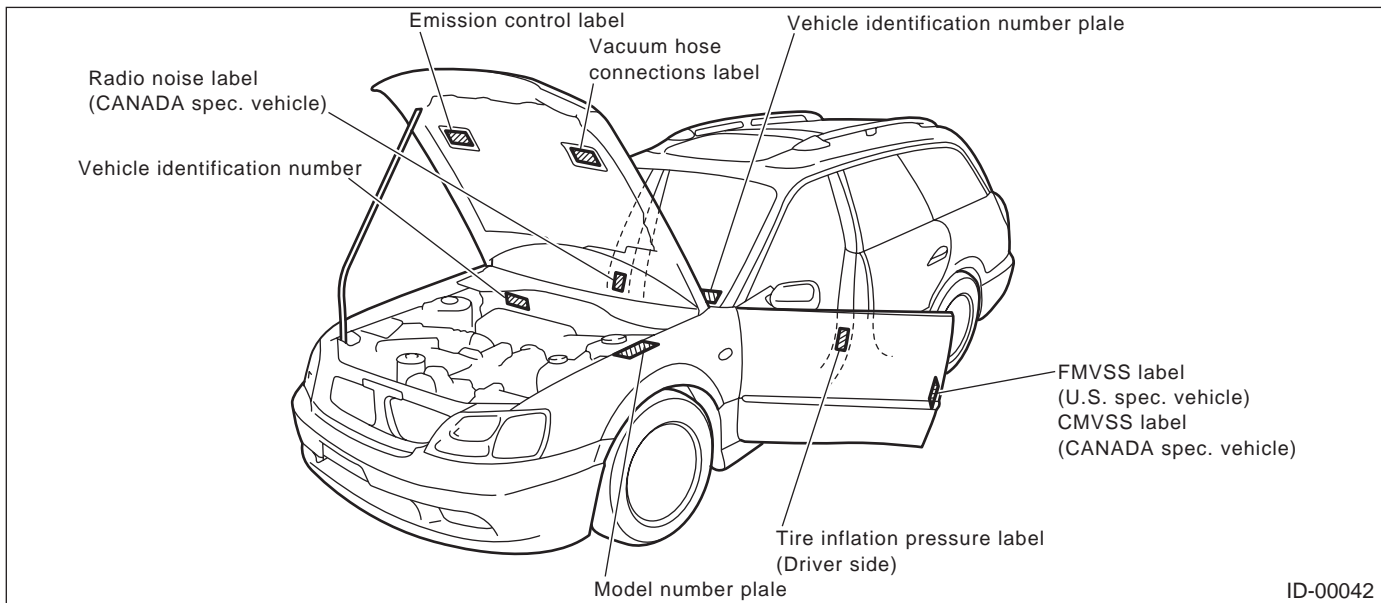

IDENTIFICATION

IDENTIFICATION

Model number plate

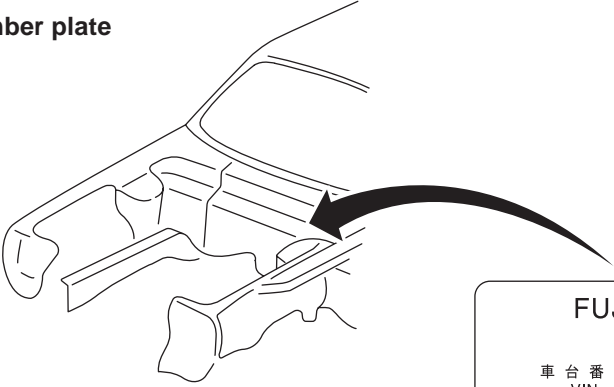

FUJI HEAVY INDUSTRIES LTD.

型式

車台番号 VIN **4S3BE635X37200001**

アプライドモデル applied model **BE9DY3J**
 オプションコード option code **E0**

トリムコード trim code **410**
 エンジン型式 engine type **EZ30DAXCBB**

外装飾コード color code **230**
 ミッション型式 transmission type **TY754VCDAA**

富士重工業株式会社

ID-00043

2. MEANING OF VIN

The meaning of the VIN is as follows:

[4S3BE635X37200001]

The starting and ending brackets ([]) are stop marks.

| Digits | Code | Meaning | Details |
|----------|--------|------------------------|---|
| 1 to 3 | 4S3 | Manufacturer body area | Passenger car, SIA made, For US/Canada/Taiwan/Chile |
| 4 | B | Car line | Legacy/OUTBACK series |
| 5 | E | Body type | E: Sedan/OUTBACK Sedan H: Station Wagon/OUTBACK Wagon |
| 6 | 6 | Displacement | 6: 2.5 L AWD 8: 3.0 L AWD |
| 7 | 3 | Grade | 2: Brighton 3: L 4: 2.5 GT 5: 2.5 GT LO 6: OUTBACK Wagon 7: OUTBACK Wagon-cold weather 8: OUTBACK Sedan-LTD, OUTBACK Wagon-LTD 9: OUTBACK Sedan-6 cylinders, OUTBACK Wagon-6 cylinders 0: OUTBACK-6 cylinders L.L.-Bean |
| 8 | 5 | Restraint | 5: Manual belts, dual airbag 6: Manual belts, dual airbag, side airbag |
| 9 | X | Check digit | 0 - 9 and X |
| 10 | 3 | Model year | 3: 2003MY 4: 2004MY 5: 2005MY |
| 11 | 7 | Transmission type | 5: Full-time AWD 4-speed AT-SS 6: Full-time AWD 5-speed MT 7: Full-time AWD 4-speed AT |
| 12 to 17 | 200001 | Manufacture number | From 200001: Sedan From 300001: Station Wagon From 600001: OUTBACK Wagon |

IDENTIFICATION

IDENTIFICATION

3. MODEL NUMBER PLATE

The model number plate indicates: the applied model, the option code, the trim code, the engine type, the transmission type, and the exterior color code. This information is helpful when placing orders for parts.

BE9DY3J

| Digits | Code | Meaning | Details |
|--------|------|--|---|
| 1 | B | Series | B: Legacy/OUTBACK |
| 2 | E | Body style | E: Sedan/OUTBACK Sedan H: Station Wagon/OUTBACK Wagon |
| 3 | 9 | Engine displacement Drive system Suspension system | 9: 2.5 L AWD E: 3.0 L AWD |
| 4 | D | Minor change | D: 2003MY (SIA made) |
| 5 | Y | Destination | Y: Left-hand drive for United States, Canada and Taiwan |
| 6 | 3 | Grade | 1: Brighton 3: L 4: OUTBACK Wagon 8: OUTBACK Sedan-6 cylinders 9: OUTBACK Sedan-LTD A: OUTBACK Wagon-cold weather B: OUTBACK Wagon-LTD C: OUTBACK Wagon-6 cylinders D: OUTBACK-6 cylinders L.L.-Bean G: 2.5 GT H: 2.5 GT LO |
| 7 | J | Transmission, fuel feed system | E: DOHC MPI 4-speed AT J: SOHC MPI center differential AWD R: SOHC MPI 4-speed AT L: SOHC MPI 4-speed AT-SS |

The engine and transmission type are as follows:

• Engine

EZ30DAXCBB

| Digits | Code | Meaning | Details |
|---------|------|-------------------------|---|
| 1 and 2 | EZ | Engine type | EJ: 4 cylinders EZ: 6 cylinders |
| 3 and 4 | 30 | Displacement | 25: 2.5 L 30: 3.0 L |
| 5 | D | Fuel feed system | 1: D-MPI SOHC-A phase-2 or -3 2: D-MPI SOHC-B phase-2 or -3 D: D-MPI DOHC 6 cylinders phase-3 |
| 6 | A | Exhaust regulations | — |
| 7 | X | Transmission | W: AWD MT X: AWD AT |
| 8 to 10 | CBB | Detailed specifications | Used when ordering parts. See the parts catalog for details. |

IDENTIFICATION

IDENTIFICATION

• Transmission

TY754VCDAA

| Digits | Code | Meaning | Details |
|---------|------|-----------------------------|--|
| 1 | T | Transmission | T: Transmission |
| 2 | Y | Transmission type | Y: Full-time AWD MT center differential V: Full-time AWD AT VTD Z: Full-time AWD AT MPT |
| 3 and 4 | 75 | Classification | 75: MT 1A, 1B: AT |
| 5 | 4 | Series | 4: 5th Generation Legacy |
| 6 | V | Transmission specifications | V: Full-time AWD 5-speed MT with viscous coupling center differential single range Z: Full-time AWD 4-speed AT with MPT Y: Full-time AWD 4-speed AT with VTD |
| 7 | C | Mounted body | C: US 2.5 L SOHC V, M: US 3.0 L DOHC |
| 8 to 10 | DAA | Detailed specifications | Used when ordering parts. See the parts catalog for details. |

• Rear differential 1

VA1REH

| Digits | Code | Meaning | Details |
|--------|------|---------------------------|----------------------------|
| 1 | V | For AWD | V: AWD |
| 2 | A | Type | A: A type |
| 3 | 1 | Hypoid gear diameter | 1: 152 dia. |
| 4 | R | Installation position | R: Rear |
| 5 | E | Reduction gear ratio | E: 4.111 |
| 6 | H | Specification differences | H: Case B with cooling fin |

• Rear differential 2

T1

| Code | Reduction gear ratio | LSD |
|------|----------------------|---------|
| T1 | 3.900 | No |
| T2 | 4.111 | No |
| JE | 4.111 | Viscous |
| CD | 4.444 | Viscous |

IDENTIFICATION

IDENTIFICATION

MEMO:

RECOMMENDED MATERIALS

RECOMMENDED MATERIALS

1. Recommended Materials

A: RECOMMENDED MATERIALS

1. GENERAL

To insure the best performance, always use the specified oil, gasoline, adhesive, sealant, etc. or a substitute of equivalent quality.

2. FUEL



Always use a gasoline of the same or higher octane value than specified in the owner's manual. Ignoring the specifications below will result in damage or poor operation of the engine and fuel injection system. Use the specified gasoline to correct performance.

• Unleaded gasoline

Use unleaded gasoline and not leaded gasoline on vehicles with catalytic converter installed to reduce air pollution. Using leaded gasoline will damage the catalytic converter.

3. LUBRICANTS

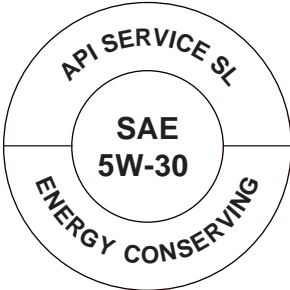
Use either the lubricants in the table below or equivalent lubricants. See the table below to choose the correct SAE viscosity.

| Lubricant | Recommended | | Alternative |
|--------------------------------|--|--------------|-------------|
| | API or ILSAC Spec. | ACEA Spec. | API Spec. |
| Engine oil | SL Grade "Energy conserving"  RM-00001 GF-3 (for vehicles with the stamp below)  RM-00002 | A1, A2 or A3 | SJ |
| Manual transmission oil | GL-5 | — | — |
| AT front differential gear oil | GL-5 | — | — |
| Rear differential gear oil | GL-5 | — | — |

RECOMMENDED MATERIALS

RECOMMENDED MATERIALS

| SAE viscosity No. and applicable temperature SAE J300 | | | | | | | | |
|--|-----|-----|-----|----|----|----|----|-----|
| Engine oil | | | | | | | | |
| (°C) | -30 | -20 | -10 | 0 | 10 | 20 | 30 | 40 |
| (°F) | -22 | -4 | 14 | 32 | 50 | 68 | 86 | 104 |
| 10W-30 or 10W-40 | | | | | | | | |
| 5W-30 Recommend | | | | | | | | |
| RM-00003 | | | | | | | | |
| Manual transmission oil and rear differential gear oil | | | | | | | | |
| (°F) | -30 | -20 | -10 | 0 | 10 | 20 | 30 | 40 |
| (°C) | -22 | -4 | 14 | 32 | 50 | 68 | 86 | 104 |
| 90 | | | | | | | | |
| 85W | | | | | | | | |
| 80W | | | | | | | | |
| 75W-90 | | | | | | | | |
| RM-00004 | | | | | | | | |

RECOMMENDED MATERIALS

RECOMMENDED MATERIALS

| SAE viscosity No. and applicable temperature SAE J300 | | | | | | | | |
|---|-----|-----|-----|----|----|----|----|--------|
| AT front differential gear oil | | | | | | | | |
| (°C) | -30 | -20 | -10 | 0 | 10 | 20 | 30 | 40 |
| (°F) | -22 | -4 | 14 | 32 | 50 | 68 | 86 | 104 |
| | | | | | | | | 90 |
| | | | | | | | | 85W |
| | | | | | | | | 80W |
| | | | | | | | | 80W-90 |

RM-00005

4. FLUID

Use the fluids specified in the table below. Do not mix two different kinds or makes of fluid.

| Fluid | Recommended | Alternative | Remarks |
|------------------------------|--------------------|--------------------|---------|
| Automatic transmission fluid | DEXRON III | — | |
| Power steering fluid | DEXRON III | — | |
| Brake fluid | FMVSS No. 116 DOT3 | FMVSS No. 116 DOT4 | |
| Clutch fluid | FMVSS No. 116 DOT3 | FMVSS No. 116 DOT4 | |

5. COOLANT

Use genuine coolant to protect the engine.

| Coolant | Recommended | Item number | Alternative |
|--------------------|-----------------|-------------|-------------|
| Coolant | SUBARU coolant | 000016218 | None |
| Water for dilution | Distilled water | — | Tap water |

6. REFRIGERANT

Standard air conditioners on Subaru vehicles use HFC134a refrigerant. Do not mix it with other refrigerants. Also, do not use any air compressor oil except for ZXL200PG.

| Air conditioner | Recommended | Item number | Alternative |
|-----------------|-------------|-------------|-------------|
| Refrigerant | HFC134a | — | None |
| Compressor oil | ZXL200PG | — | None |

RECOMMENDED MATERIALS

RECOMMENDED MATERIALS

7. GREASE

Use the grease and supplementary lubricants shown in the table below.

| Grease | Application point | Recommended | Item number | Alternative |
|--------------------------|---|--------------------|-------------|-------------|
| Supplementary lubricants | <ul style="list-style-type: none"> • O2 sensor • Bolts, etc. | SUBARU CRC | 004301003 | — |
| Grease | MT main shaft | FX clutch grease | 000040901 | — |
| | Clutch master cylinder push rod | Slicolube G-40M | 004404003 | — |
| | <ul style="list-style-type: none"> • Gear shift lever • Select lever • Clutch operating cylinder • Accelerator pedal • Clutch pedal • Brake pedal • Clutch bearing • Clutch release lever • Steering shaft bearing | SUNLIGHT2 | 003602010 | — |
| | Steering gear box | Valiant grease M-2 | 003608001 | — |
| | <ul style="list-style-type: none"> • Disc brake • Drum brake wheel cylinder | Niglube RX-2 | K0779GA102 | — |
| | Drum brake | Molykote No. 7439 | 003602001 | — |
| | <ul style="list-style-type: none"> • Brake pad • Brake shoe | Molykote AS-880N | K0777YA010 | — |
| | Front axle SFJ | SSG-6003 | 28093TA000 | — |
| | Front axle BJ | NTG2218 | 28093AA000 | — |
| | Rear axle BJ | Molylex No. 2 | 003601001 | — |
| | Rear axle DOJ | VU-3A702 | 23223GA050 | — |
| | <ul style="list-style-type: none"> • Throttle cable end • Door latch • Door striker | Slicolube G-30M | 004404002 | — |

8. ADHESIVES

Use the adhesives shown in the table below, or equivalent.

| Adhesive | Application point | Recommended | Item number | Alternative |
|----------|---------------------|----------------------------------|-------------|--|
| Adhesive | Windshield and body | Essex Chemical Crop's Urethane E | — | Sunstar 580 |
| | Soft vinyl | Cemedine 540 | — | 3M's EC-776 EC-847 or EC-1022 (Spray type) |
| | Momentary sealant | Cemedine 3000 | — | Armstrong's Eastman 910 |

9. SEAL MATERIAL

Use seal material shown in the table below, or equivalent.

| Seal material | Application point | Recommended | Item number | Alternative |
|---------------|--|-------------------|-------------|------------------------|
| | <ul style="list-style-type: none"> • Cylinder block • Torque converter clutch case | Three Bond 1215 | 004403007 | Dow Corning's No. 7038 |
| | Transmission oil pan | Three Bond 1217B | K0877YA020 | — |
| | Rear differential | Three Bond 1324 | 004403042 | — |
| | Rear differential | Three Bond 1105 | 004403010 | Dow Corning's No. 7038 |
| | Weatherstrip | Starcalking B-33A | 000018901 | Butyl Rubber sealant |
| | Steering adjusting screw | Three Bond 1141 | 004403006 | — |
| | <ul style="list-style-type: none"> • Camshaft cap • H6 oil pan, chain cover | Three Bond 1280B | K0877YA018 | — |

RECOMMENDED MATERIALS

RECOMMENDED MATERIALS

MEMO:

RM-6

PRE-DELIVERY INSPECTION

PRE-DELIVERY INSPECTION

1. Pre-delivery Inspection

A: GENERAL

The purposes of the pre-delivery inspection (PDI) are as follows.

- Remove the additional parts used for ensuring the vehicle quality during transportation and restore the vehicle to its normal state.
- Check if the vehicle before delivery is in a normal state.
- Check for any damage or missing parts that may have taken place during transportation or storage.
- Make sure to provide a complete vehicle to the customer.

Because of the above reasons, all dealerships must always carry out the PDIs before delivering a vehicle.

In addition, all franchised shops and PDI centers must check the status of every vehicle received to identify who is responsible for any possible defects.

PRE-DELIVERY INSPECTION

PRE-DELIVERY INSPECTION

B: PDI PROCEDURE

Follow the procedures shown in the table below.

Static Checks Just After Vehicle Receipt

| Step | Check point |
|---|--|
| 1. Appearance check | (1) If the vehicle is covered with protective film, visually check the vehicle body for damage and dents. (2) If the protective film has been removed, visually check the body paints for small areas of damage or stains. (3) Visually check the glass and light lenses for any damage and cracks or excessive gaps to the body sheet metal. (4) Visually check the plated parts for any damage. |
| 2. Tire check | (1) Check the tires for damage, abnormal conditions, and dents on the wheels. (2) Check the tire air pressure. |
| 3. Fuse installation | (1) If the vehicle is about to be delivered to the customer, attach a fuse. |
| 4. Connection of air conditioner relay | (1) If the vehicle is about to be delivered to the customer, connect the air conditioner relay. |
| 5. Check the doors for lock/unlock and open/close operations. | (1) Using the key, check if the door can be locked and unlocked normally. (2) Open and close the all doors to see that there are no abnormal conditions. |
| 6. Operation check of child lock system | (1) Inspect whether child lock system operates properly. |
| 7. Check the trunk lid open/close operations. | (1) Operate the trunk lock release lever to check that the trunk opens normally. (2) Using the key, check if the trunk lid can be unlocked normally. (3) Open and close the trunk lid to see that there are no abnormal conditions. |
| 8. Check the rear gate for lock/unlock and open/close operations. | (1) Using the key, check if the rear gate can be lock and unlocked normally. (2) Open and close the rear gate to see that there are no abnormal conditions. (3) Operate the power door locking switch to check that the rear gate is locked and unlocked normally. |
| 9. Operation check of trunk lid release handle | (1) Operate the trunk lid release lever to check the trunk is unlocked normally. |
| 10. Operation check of fuel lid opener lock release lever | (1) Operate the fuel lid opener to check that the fuel lid is unlocked normally. |
| 11. Accessory check | Check the following accessories are provided: <ul style="list-style-type: none"> • Owner's manual • Warranty booklet • Service booklet • Spare key • Jack • Tool set • Spare tire |
| 12. Operation check of hood lock release system | (1) Operate the hood lock release lever to check that the hood opens normally. |
| 13. Battery | (1) Check the battery for any abnormal conditions such as rust and trace of battery fluid leaks. |
| 14. Brake fluid | (1) Check the fluid amount. |
| 15. Engine oil | (1) Check the oil amount. |
| 16. Transmission fluid | (1) Check the fluid amount. |
| 17. AT front differential oil | (1) Check the AT front differential oil amount. |
| 18. Coolant | (1) Check the coolant amount. |
| 19. Clutch fluid | (1) Check the clutch fluid amount. |
| 20. Window washer fluid | (1) Check the window washer fluid amount. |
| 21. Hood latch check | (1) Check that the front hood is closed and latched securely. |
| 22. Keyless entry system | (1) Check that the keyless entry system operates normally. |
| 23. Security system | (1) Check that the security system operates normally. |

PRE-DELIVERY INSPECTION

PRE-DELIVERY INSPECTION

| Step | Check point |
|---------------------|--|
| 24. Seat | (1) Check the seat surfaces for smears or dirt. (2) Check the seat installation conditions and functionality. |
| 25. Seat belt | (1) Check the seat belt installation conditions and functionality. |
| 26. Wheel alignment | (1) Check that the wheel alignments are properly adjusted. |

Checks with the Engine Running

| Step | Check point |
|---|--|
| 1. Test mode connector | (1) Disconnect the test mode connector. |
| 2. Operation check of shift lock system, key interlock, and starter interlock | (1) For a MT vehicle, check the starter interlock system operations. (2) For an AT vehicle, check the shift lock and key interlock system operations. |
| 3. Starting condition | (1) Start the engine and check that the engine starts smoothly. |
| 4. Exhaust system | (1) Check that the exhaust noise is normal and no leaks are found. |
| 5. Indicator light | (1) Check that all the indicator lights operate normally. |
| 6. Clock | (1) Check that the clock operate normally. |
| 7. Radio | (1) Check that the radio system operates normally. |
| 8. Cigarette lighter | (1) Check that the cigarette lighter operates normally. |
| 9. Lighting system | (1) Check that the lighting systems operate normally. |
| 10. Window washer | (1) Check that the window washer system operates normally. |
| 11. Wiper | (1) Check that the wiper system operates normally. |
| 12. Power window operation check | (1) Check the power window for correct operations. |

Dynamic Test with the Vehicle Running

| Step | Check point |
|-------------------------|---|
| 1. Brake test | (1) Check that the foot brake operates normally. |
| 2. Parking brake | (1) Check that the parking brake operates normally. |
| 3. AT shift control | (1) Check the AT shift patterns are correct. |
| 4. Heater & ventilation | (1) Check that the heater & ventilation system operates normally. |
| 5. Air conditioner | (1) Check that the air conditioner operates normally. |
| 6. Cruise control | (1) Check that the cruise control system operates normally. |

Checks after Dynamic Test

| Step | Check point |
|-------------------------------|---|
| 1. ATF level | (1) Check that the ATF level is normal. |
| 2. Power steering fluid level | (1) Check that the power steering fluid level is normal. |
| 3. Fluid leak check | (1) Check for fluid/oil leaks. |
| 4. Water leak check | (1) Spray the vehicle with water and check for water leaks. |
| 5. Appearance check 2 | (1) Remove the protective film (if any). (2) Check the body paints for damage and smears. (3) Check the plated parts for damage and rust. |

PRE-DELIVERY INSPECTION

PRE-DELIVERY INSPECTION

1. APPEARANCE CHECK

- 1) When vehicle is covered with protective film, inspect visually for damage or dents to vehicle body surface.
- 2) When protective film is removed, check the body paints for small areas of damage or stains and repair as necessary.
- 3) Check the window glass, door glass, and lights for any cracks or damage and repair or replace the parts as necessary.
- 4) Check the plated parts, such as the grilles and door knobs, for damage or loss of gloss and repair or replace the parts as necessary.

2. TIRE CHECK

- Check the tire outer faces for any damage.
- Check the tire air pressure by referring to the following table.

| Tire size | Tire inflation pressure kPa (kg/cm ² , psi) | |
|------------|---|---------------|
| | Front | Rear |
| P195/60R15 | 230 (2.3, 33) | 220 (2.2, 32) |
| P205/60R15 | 220 (2.2, 32) | 210 (2.1, 30) |
| R205/55R16 | 220 (2.2, 32) | 210 (2.1, 30) |
| P225/60R16 | 210 (2.1, 30) | 200 (2.0, 29) |

3. FUSE INSTALLATION

A vehicle just delivered has no fuses for the circuit to prevent battery discharge. Attach a 15 A fuse as shown in the figure.

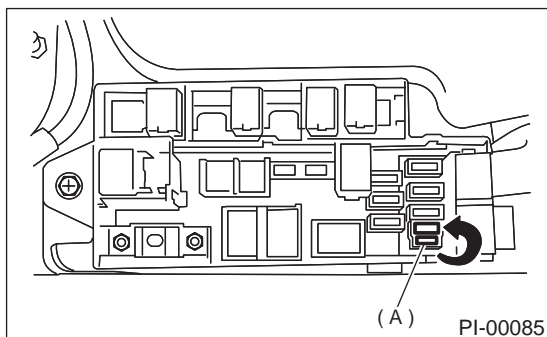

4. CONNECTION OF AIR CONDITIONER RELAY

A vehicle just delivered has its air conditioner relay disconnected to protect the air conditioner compressor.

Switch air conditioner relay position as shown in the figure below.

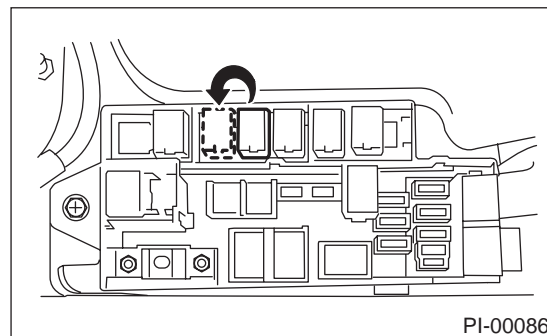

5. CHECK THE DOOR OPERATIONS, LOCK/UNLOCK AND OPEN/CLOSE, AS FOLLOWS.

Using the key, lock and unlock the door several times to check for normal operation. Open and close the door several times for smooth movement.

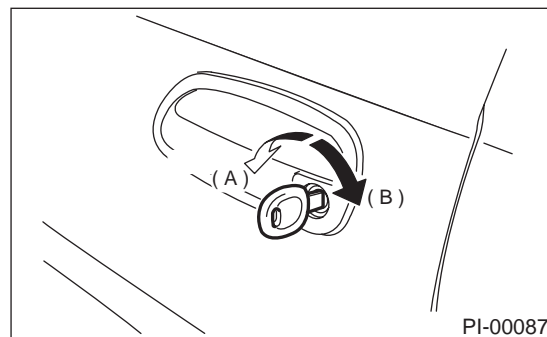

- (A) Unlock
- (B) Lock

• Vehicles with manual door locks:

Sit in the driver seat, close the door completely, and move the lock lever to the lock position. Then, pull the inside door handle to ensure the door will not open.

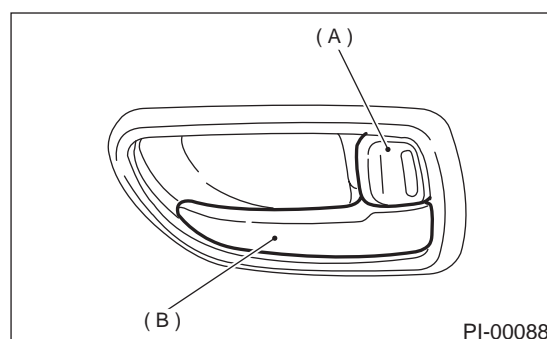

- (A) Lock lever
- (B) Inside door handle

PRE-DELIVERY INSPECTION

PRE-DELIVERY INSPECTION

• Vehicles with power door locks:

Sit in the driver seat, close the driver's door completely, and place the power door locking switch to the lock position. Then pull the all inside door handles to ensure that the all doors will not open.

Sit in the passenger seat, do the same procedure as for the driver seat.

• Driver's side

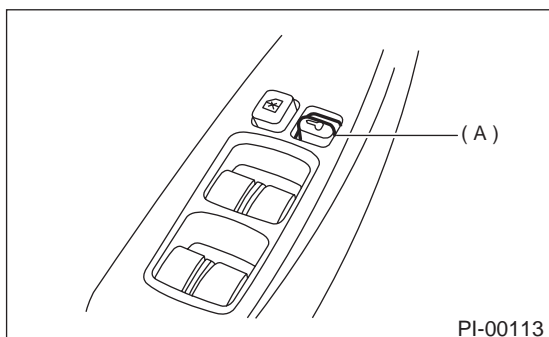

(A) Power door lock switch

• Passenger side

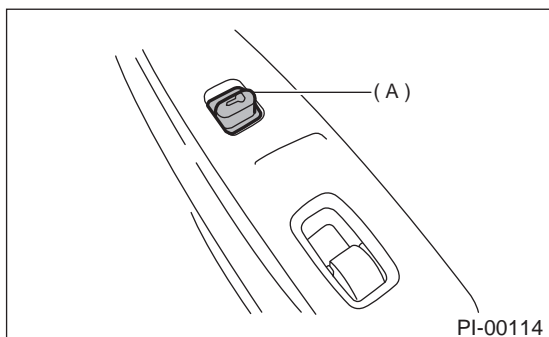

(A) Power door lock switch

For other doors, place the lock levers to the lock positions and then pull the inside door handles to ensure that the doors will not open.

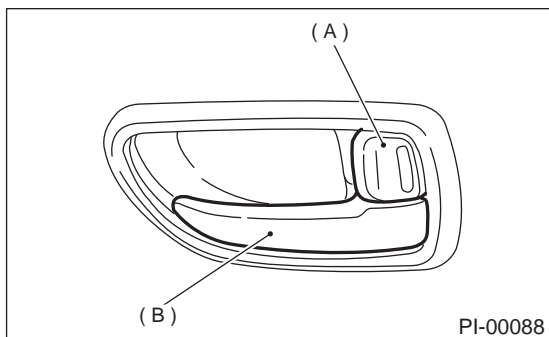

(A) Lock lever
(B) Inside door handle

6. CHECK THE OPERATION OF CHILD SAFETY LOCKS

- 1) Set the child safety lock on both rear doors to the lock positions.
- 2) Close the rear doors completely.
- 3) Check that the lock levers of the rear doors are in the unlock positions. Then, pull the inside door handles of the rear doors to ensure that the doors will open.
- 4) Next, pull the outside door handles of the rear doors to ensure that the doors will open.

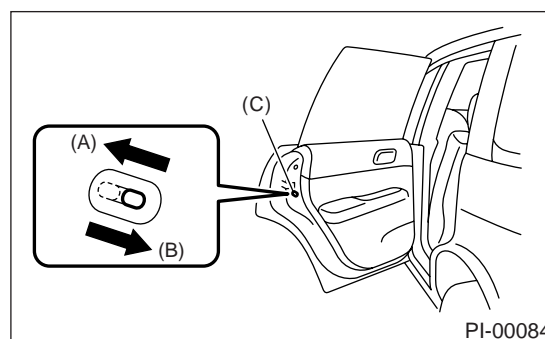

(A) Unlock
(B) Lock
(C) Child safety lock

7. CHECK THE TRUNK LID OPERATIONS, OPEN/CLOSE, AS FOLLOWS.

- Operate the trunk lock release lever and verify that the trunk lid opens.
- Using the key, open the trunk lid several times to check for normal operation.
- Open and close the trunk lid several times for smooth movement.

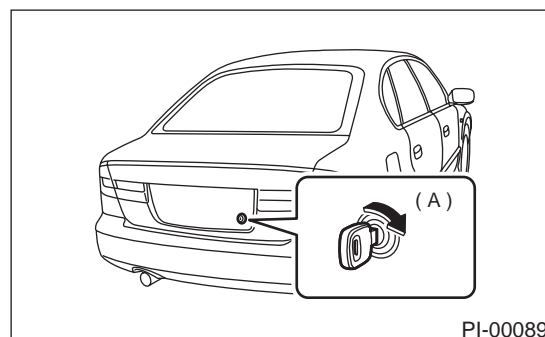

(A) Open

PRE-DELIVERY INSPECTION

PRE-DELIVERY INSPECTION

- Set the trunk lid release lever to the cancel position, and check that the trunk lid can only be opened with the key.

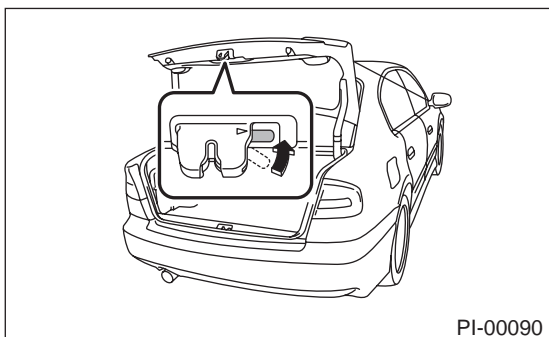

8. CHECK THE REAR GATE OPERATIONS, LOCK/UNLOCK AND OPEN/CLOSE, AS FOLLOWS.

- Using the key, lock and unlock the rear gate several times to check for normal operation.
- Open and close the rear gate several times for smooth movement.

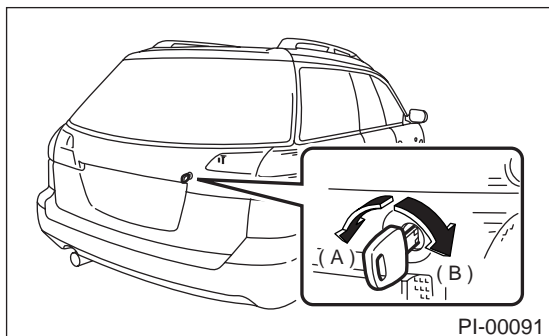

- (A) Lock
- (B) Unlock

- Operate the power door locking witch to check that the rear gate is locked and unlocked normally.

9. OPERATION CHECK OF TRUNK LID RELEASE HANDLE

- 1) Use a screwdriver with a thin blade. Slide the screwdriver blade from the slit aperture of the lock assembly fully to the end until you hear a click. This places the latch in the locked position.

Locked

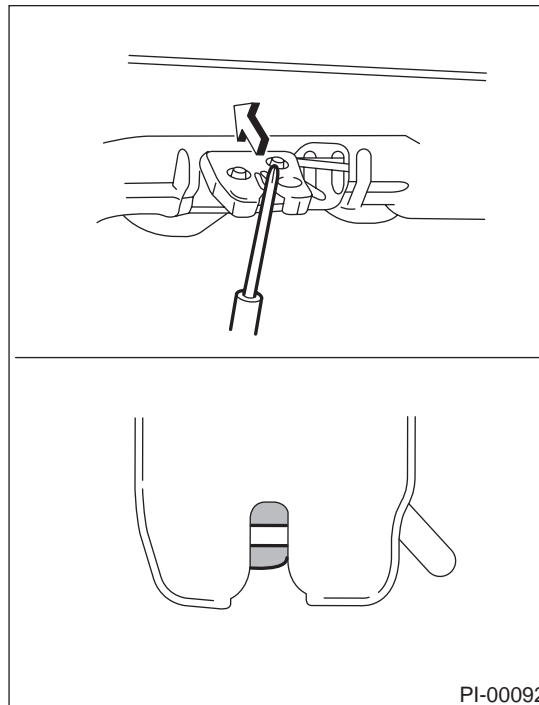

- 2) Move the release handle from outside the vehicle, in the direction of the arrow to check if the latch is released.

Released

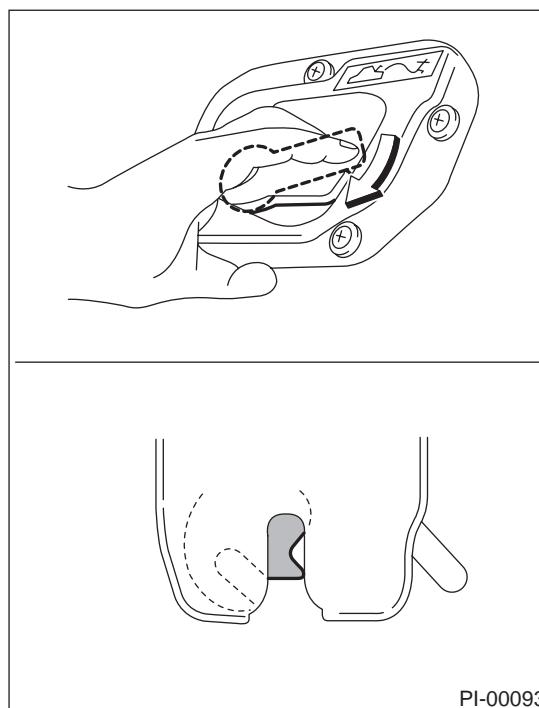

PRE-DELIVERY INSPECTION

PRE-DELIVERY INSPECTION

10. OPERATION CHECK OF FUEL LID OPENER LOCK RELEASE LEVER

Operate the fuel lid opener and verify that the fuel lid opens normally. Check that the filler cap is securely closed.

11. ACCESSORY CHECK

Check that the following accessories are provided in the luggage compartment or cargo area.

- Owner's manual
- Warranty booklet
- Service booklet
- Spare key
- Jack
- Tool set
- Spare tire

Sedan

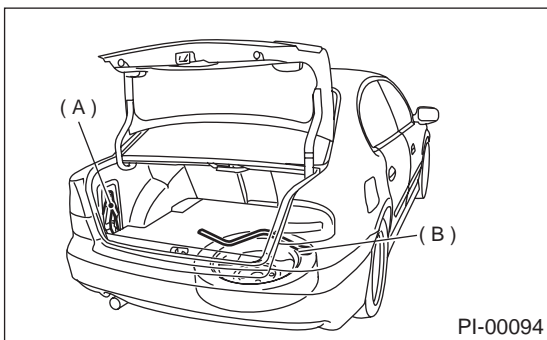

- (A) Jack
- (B) Jack handle

Wagon

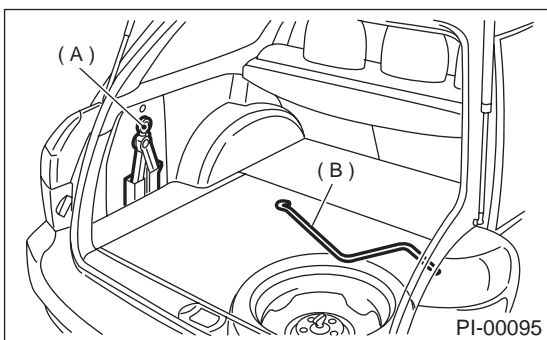

- (A) Jack
- (B) Jack handle

12. OPERATION CHECK OF HOOD LOCK RELEASE SYSTEM

By operating front hood release knob, confirm front hood will unlock properly.

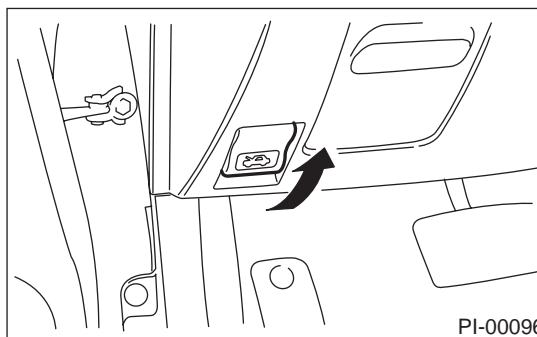

By operating lever, confirm front hood will open properly. Next, support the front hood with front hood stay.

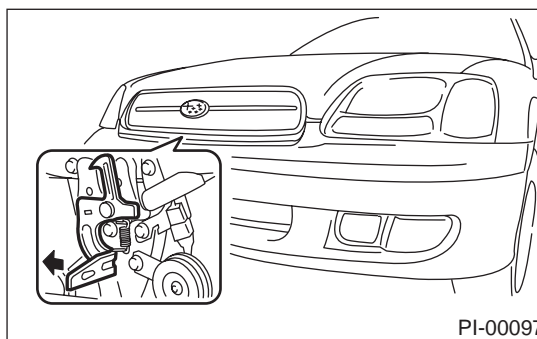

13. BATTERY

Check the battery terminals to make sure that no rust or corruptions due to fluid leaks are found. Check that the battery cap is securely tightened.

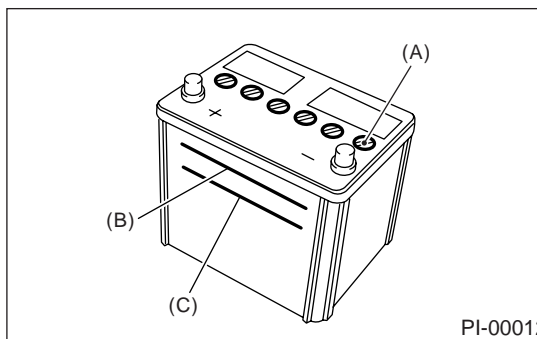

- (A) Cap
- (B) Upper level
- (C) Lower level

PRE-DELIVERY INSPECTION

PRE-DELIVERY INSPECTION

14. BRAKE FLUID

Check the brake fluid amount. If the amount is insufficient, carry out a brake line test to identify brake fluid leaks and check the brake operation. After that, refill the brake fluid tank with the specified type of fluid.

15. ENGINE OIL

Check the engine oil amount. If the amount is insufficient, check that no leaks are found. Then, add the necessary amount of the specified engine oil.

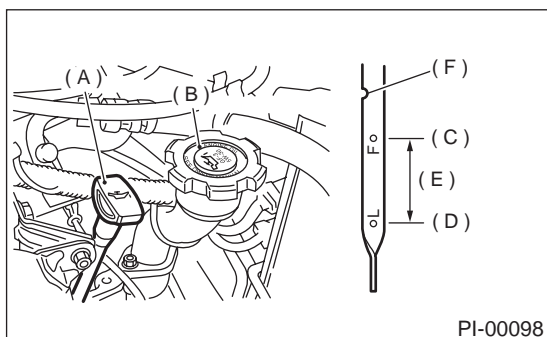

- (A) Oil level gauge
- (B) Engine oil filler cap
- (C) Upper level
- (D) Lower level
- (E) Approx. 1.0 ℓ (1.1 US qt, 0.9 Imp qt)

16. TRANSMISSION FLUID

Check the transmission fluid amount. If the amount is insufficient, check that no leaks are found. Then, add the necessary amount of the specified fluid.

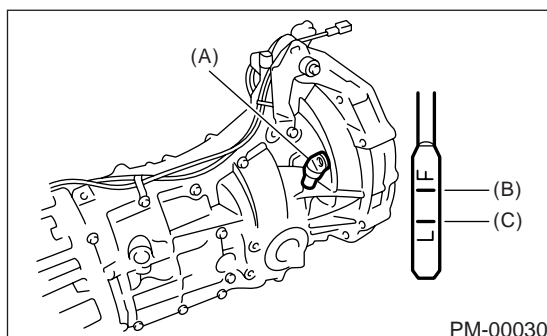

- (A) Oil level gauge
- (B) Upper level
- (C) Lower level

17. AT FRONT DIFFERENTIAL OIL

Check the AT front differential oil amount. If the amount is insufficient, check that no leaks are found. Then, add the necessary amount of the specified AT front differential oil.

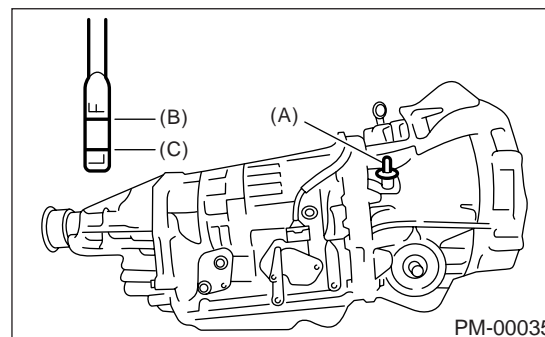

- (A) Oil level gauge
- (B) Upper level
- (C) Lower level

18. COOLANT

Check the coolant amount on the reservoir. If the amount is insufficient, check that no leaks are found. Then, add the necessary amount of coolant with the specified concentration.

19. CLUTCH FLUID

Check the clutch fluid amount. If the amount is insufficient, check that no leaks are found. Then, add the necessary amount of the specified fluid.

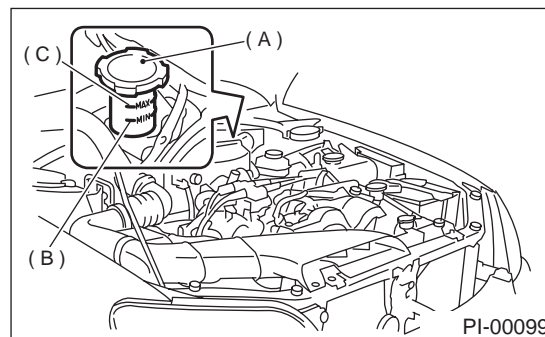

- (A) Reservoir tank
- (B) MIN level
- (C) MAX level

20. WINDOW WASHER FLUID

Check the window washer fluid amount. If the amount is insufficient, check that no leaks are found. Then, add the necessary amount of washer fluid commercially available.

PRE-DELIVERY INSPECTION

PRE-DELIVERY INSPECTION

21. FRONT HOOD LATCH CHECK

Retract the front hood stay and close the hood. Check that the front hood is securely latched.

22. KEYLESS ENTRY SYSTEM

Check the keyless entry system operations as follows:

- Fully open all the door windows.
- Remove the key from the ignition switch and close all the doors including rear gate.
- Press the "LOCK/ARM" button on the transmitter momentarily once and check if all the doors are locked, the buzzer chirps once, and the hazard light flashes once.

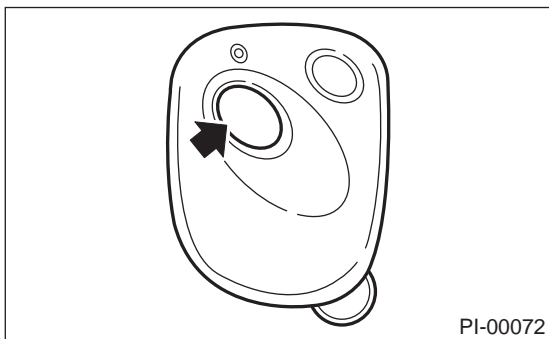

- Press the "UNLOCK/DISARM" button on the transmitter momentarily once and check if the driver's door is unlocked, the buzzer chirps twice, and the hazard light flashes twice.



- Press the "UNLOCK/DISARM" button on the transmitter momentarily once again within five seconds and check if all the doors including the rear gate on wagon are unlocked.
- Press the "LOCK/ARM" button on the transmitter a little bit of time (approx. 2 sec.) and check if a panicking condition occurs; the horn sounds and hazard lamp blinks continuously. Also, check if that condition lasts for 30 seconds or until any button of the transmitter is pressed.
- Press the "LOCK/ARM" button on the transmitter momentarily once with one of the doors including the rear gate and trunk lid open and check if the buzzer chirps and hazard lamp blinks five times to warn of a door ajar.

Then, bring all the doors including the rear gate and trunk lid in closed condition and check if all the doors are locked, the buzzer chirps once, and the hazard light flashes once.

- Within a distance of 10 m (33 ft) from a vehicle, press transmitter's "LOCK/SET" button three times within 5 seconds. Confirm that horn rings once, hazard lamp blinks three times.
- Move the power door locking switch to "LOCK" position with any one of the doors including the rear gate open. Then, bring all the doors including the rear gate in the closed condition and check if all the doors are locked, the buzzer chirps once, and the hazard light flashes once.

- Driver's seat

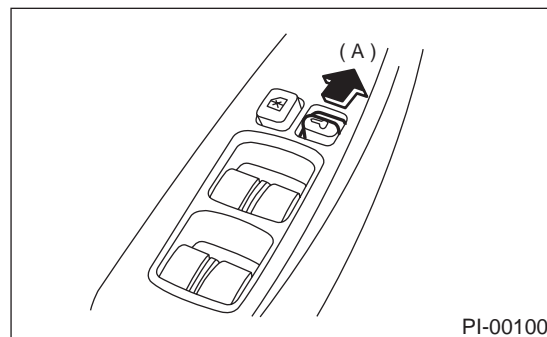

(A) Lock

- Passenger seat

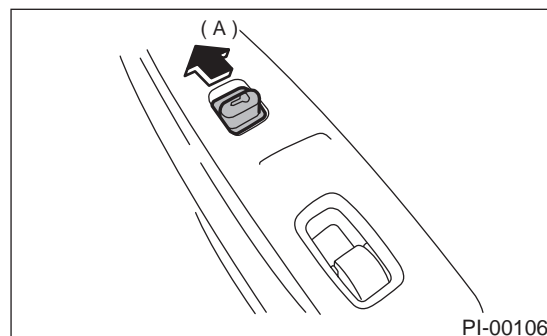

(A) Lock

Check selecting audible buzzer operation.

- Will give you an audible buzzer when the doors lock and unlock.

If desired, you may turn the audible buzzer off.

To turn the audible buzzer off, carry out the unlocking procedure of keyless entry system, then simultaneously depress LOCK/ARM and UNLOCK/DISARM buttons for more than two seconds.

The buzzer will sound twice, and hazard light will flash twice to inform you that the audible signal has been turned off.

To turn the audible buzzer on, carry out the unlocking procedure of keyless entry system, then simul-

PRE-DELIVERY INSPECTION

PRE-DELIVERY INSPECTION

taneously depress LOCK/ARM and UNLOCK/DISARM buttons for more than two seconds. The buzzer will sound once and hazard light will flash once to inform you that the audible buzzer has been turned on.

23. SECURITY SYSTEM

Check the security system operations as follows:

- Fully open all the door windows.
- Remove the key from the ignition switch and close all the doors including rear gate.
- Press the "LOCK/ARM" button on the transmitter momentarily once and check if all the doors are locked, the buzzer chirps once, the hazard lights flash once and the security indicator light flashes slowly to ensure that the security system has been brought into the arming state.

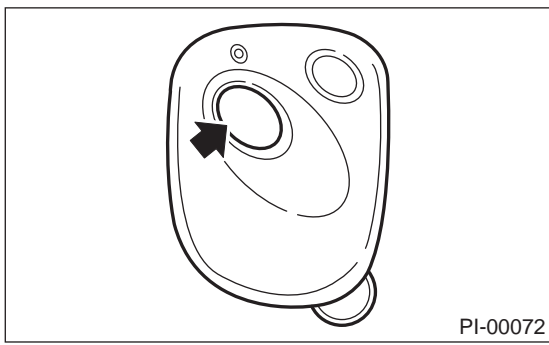

- Press the "UNLOCK/DISARM" button on the transmitter momentarily once and check if the driver's door is unlocked, the buzzer chirps twice, the hazard light flash twice, the dome light illuminates and the security indicator light goes off to ensure that the system has been brought into the disarming state.

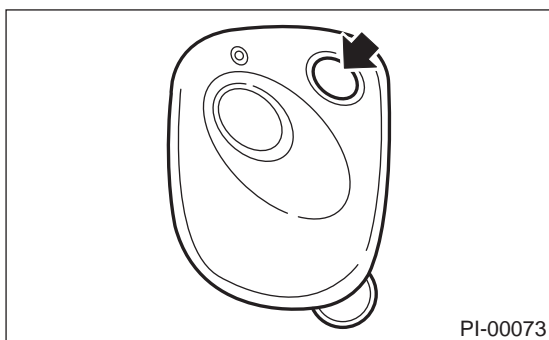

- Press the "UNLOCK/DISARM" button on the transmitter momentarily once again within five seconds and check if all the doors including the rear gate on wagon are unlocked.
- Press the "LOCK/ARM" button on the transmitter a little bit of time (approx. 2 sec.) and check if a panicking condition occurs; the horn sounds continuously, the hazard lights flash and the security indicator light flashes rapidly. Also, check if that

condition lasts for 30 seconds or until any button of the transmitter is pressed.

- Press the "LOCK/ARM" button on the transmitter momentarily once with one of the doors including the rear gate and trunk lid open and check if the buzzer chirps five times and hazard lamp blinks five times to warn of a door ajar.

Then, bring all the doors including the rear gate and trunk lid in closed condition and check if the arming condition is brought about; all the doors are locked, the buzzer chirps once and the hazard lights flash once.

- Move the power door locking switch to "LOCK" position with any one of the doors including the rear gate open. Then, bring all the doors including the rear gate in the closed condition and check if all the doors are locked, the buzzer chirps once and the hazard lights flash once to ensure that the security system has been brought into the arming state.

- Driver's seat

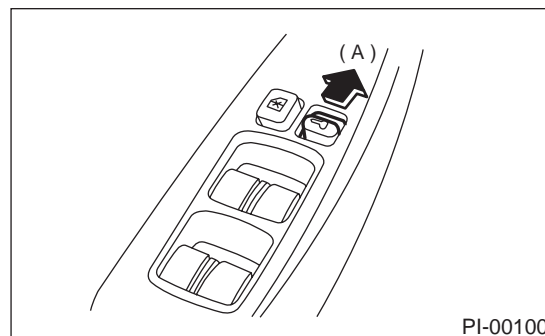

(A) Lock

- Passenger seat

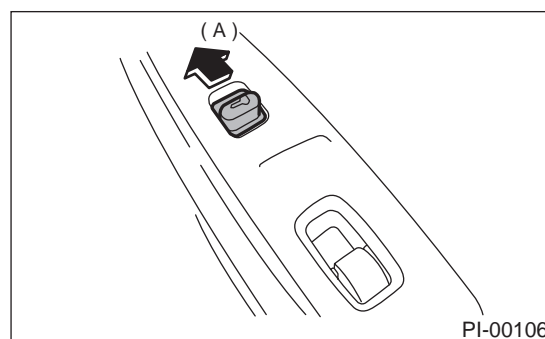

(A) Lock

- Unlock a door using the lock levers or the key and open the door while the security system is in the arming state. Check to ensure that the panicking condition occurs, i.e. the horn sounds continuously, the hazard lights flash and security indicator light flashes rapidly, and that it lasts for 30 seconds or until the "UNLOCK/DISARM" button on the transmitter is pressed. Also, check to ensure that

PRE-DELIVERY INSPECTION

PRE-DELIVERY INSPECTION

turning the ignition key to the "START" position in the arming state does not cause the starter motor to turn, thus the engine being prevented from starting.

- Apply a shock to the vehicle body with the security system in arming state, and check to ensure that the panicking condition occurs.
- Troubleshoot the security system if any one of the above-mentioned checks does not meet the requirements.

24. SEAT

Check that each seat provides full functionality in sliding and reclining. Check all available functions of the rear seat such as a trunk-through center arm rest.

25. SEAT BELT

Pull out the seat belt and then release it. Check that the belt webbing retracts smoothly.

26. WHEEL ALIGNMENT

Check the wheel alignments. <Ref. to FS-6, Wheel Alignment.> and <Ref. to RS-8, Wheel Alignment.>

27. TEST MODE CONNECTOR

Turn the ignition switch to ON and check that the check-engine light starts blinking. If the light blinks, return the ignition key to LOCK and disconnect the test mode connector. Then, turn the ignition key to ON again. If the check-engine light blinks at that time in spite of the disconnected test mode connector, carry out an engine diagnosis.

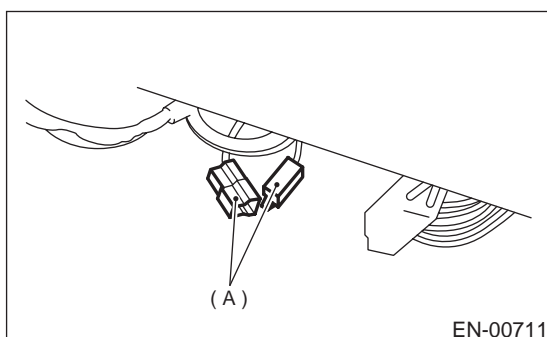

(A) Test mode connector (Green)

28. OPERATION CHECK OF SHIFT LOCK SYSTEM, KEY INTERLOCK, AND STARTER INTERLOCK

- For an MT vehicle, check the starter interlock system operations.
- For an AT vehicle, check the shift lock and key interlock system operations.

29. STARTING CONDITION

Start the engine and check that the engine starts smoothly. If any battery voltage problems are found, recharge or replace the battery. If any abnormal noises are observed, immediately stop the engine and check and repair the necessary components.

30. EXHAUST SYSTEM

Listen to the exhaust noise to see if no abnormal noises are observed.

31. INDICATOR LIGHT

Check that all the indicator lights are off.

32. CLOCK

Check the clock for normal operations and enough accuracy.

33. RADIO

Check the radio for full functionality and normal noise level. Also check the CD unit operations.

34. CIGARETTE LIGHTER

Check that the cigarette lighter operations.

35. LIGHTING SYSTEM

- Check the headlight operations.
- Check the brake light operations.
- Check the other lights for normal operations.

36. WINDOW WASHER

• Before inspection of the window washer system, connect the washer connector to the washer motor.

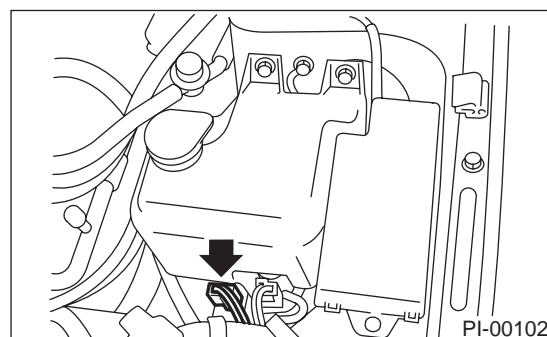

- Check that the window washer system injects washer fluid to the specified area of the windshield shown in the figure.

NOTE:

If the washer fluid does not cover the specified area, clean the nozzle.

PRE-DELIVERY INSPECTION

PRE-DELIVERY INSPECTION

Front

Injection position:

A: 300 mm (11.81 in)

B: 100 mm (3.94 in)

C: 200 mm (7.87 in)

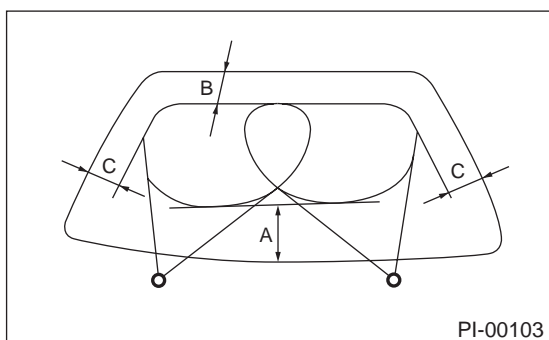

PI-00103

Rear

Injection position:

A: 60 mm (2.36 in)

B: 42°

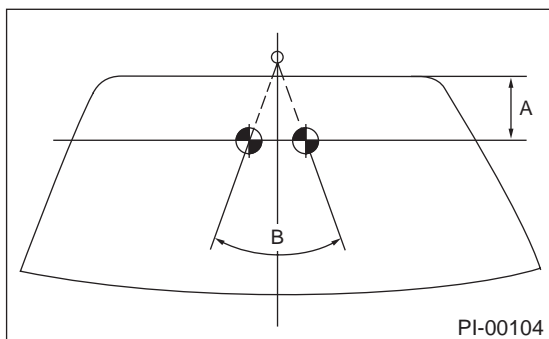

PI-00104

37.WIPER

Check the front and rear wipers for normal operations.

38.POWER WINDOW OPERATION CHECK

Manipulate the power window switches one by one to check that each of the power windows goes up and down with no abnormal noises.

39.BRAKE TEST

Check the foot brake for normal operations.

40.PARKING BRAKE

Check the parking brake for normal operations.

41.AT SHIFT CONTROL

Set the AT select lever to each gear position while checking that the demanded gear position is correctly attained.

- Except SPORT shift

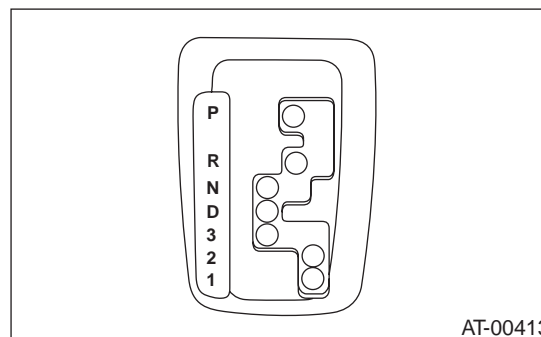

AT-00413

- SPORT shift

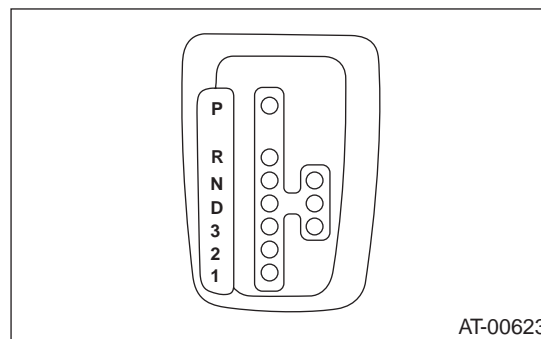

AT-00623

| Selector Position | Gear Position | | | |
|-------------------|---------------|-----|-----|-----|
| | 1st | 2nd | 3rd | 4th |
| D | Yes | Yes | Yes | Yes |
| 3 | Yes | Yes | Yes | |
| 2 | | Yes | | |
| 1 | Yes | | | |
| SPORT shift | Yes | Yes | Yes | Yes |

42.HEATER & VENTILATION

Operate the heater and ventilation system to check for normal airflow and heating capacity.

43.AIR CONDITIONER

Operate the air conditioner. Check that the A/C compressor operates normally and enough cooling is provided.

44.CRUISE CONTROL

Operate the cruise control system. Check that the system is activated and deactivated correctly.

PRE-DELIVERY INSPECTION

PRE-DELIVERY INSPECTION

45.ATF LEVEL

Check that the ATF level is normal. If insufficient, check that no leaks are found. Then add the necessary amount of the specified ATF.

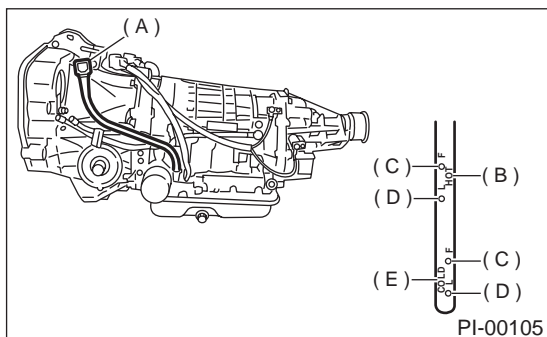

- (A) Level gauge
- (B) "HOT" side
- (C) Upper level
- (D) Lower level
- (E) "COLD" side

46.POWER STEERING FLUID LEVEL

Check that the power steering fluid level is normal. If insufficient, check that no leaks are found. Then add the necessary amount of the specified power steering fluid.

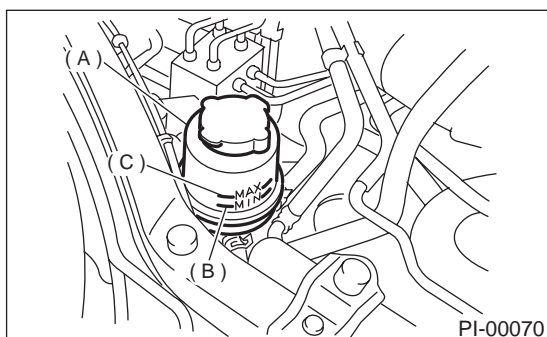

- (A) Reservoir tank
- (B) MIN level
- (C) MAX level

47.FLUID LEAK CHECK

Check the entire areas of the vehicle for any trace of coolant/oil/fluid leaks.

48.WATER LEAK TEST

Spray the vehicle with water and check that no water enters the passenger compartment.

- Before performing the water leakage test, remove anything that may obstruct the operation or which must be kept dry.
- Close all of the windows completely, and then close all of the doors tightly. Close the hood and trunk lid before starting the test.
- Connect a hose to a tap, and spray water on the vehicle. The rate of water discharge must be approx. 20 to 25 liters (5.3 to 6.6 US gal, 4.4 to 5.5 Imp gal) per minute.

When spraying water on areas adjacent to the floor and wheel house, increase the pressure. When directing water on areas other than the floor portion and wheel house, decrease the pressure. But the force of water must be made strong occasionally by pressing the end of the hose.

NOTE:

Be sure to keep the hose at least 10 cm (3.9 in) from the vehicle.

- Check the following areas:
 - Front window and body framework mating portion
 - Door mating portions
 - Glass mating portions
 - Rear quarter window mating portions
 - Rear window and body framework mating portion
 - Around roof drips
- If any dampness in the compartments is discovered after the water has been applied, carefully check all areas that may have possibly contributed to the leak.

49.APPEARANCE CHECK 2

1) When vehicle body is covered with protective film, peel it off.

NOTE:

- Use of steam eases peeling off the wrap guard.
- When performing on the vehicles left for a long time, or during low temperature period, sprinkle some water heated to 50 — 60 °C (122 — 140 °F) over the vehicle to raise its surface temperature before peeling off the wrap guard.

Do not use the water heated to over 60 °C (140 °F).

- If the adhesive remains on the coated surface, rub the portion with a flannel rag, etc. soaked with a coat of coating wax or a solvent, such as oil benzene and IPA, and then wipe it off.
- Avoid adhesion of the solvent to resin or rubber components. Do not use coating wax or a solvent while the component surface temperature is high due to hot weather, etc.

PRE-DELIVERY INSPECTION

PRE-DELIVERY INSPECTION

- If the coated surface is swollen out due to seams or moisture, expose the vehicle to the sun light for a few hours. Otherwise, heat the portion with seams or moisture using a dryer, etc.
 - Dispose of the peeled wrap guard as burnable industrial garbage.
- 2) Check the vehicle body paints, plated faces, glass, and lenses for any dirt or damage.

PRE-DELIVERY INSPECTION

PRE-DELIVERY INSPECTION

MEMO:

GENERAL DESCRIPTION

PERIODIC MAINTENANCE SERVICES

1. General Description

A: GENERAL

Be sure to perform periodic maintenance in order to maintain vehicle performance and find problems before they become serious.

SCHEDULE

PERIODIC MAINTENANCE SERVICES

2. Schedule

A: MAINTENANCE SCHEDULE 1

| | | MAINTENANCE INTERVAL | | | | | | | | | | | | | | | | | Remarks |
|---------------|----------------------------------|--|-----|----|------|-----|------|----|------|-----|------|-----|------|-----|------|-----|-------|--------------------|---------|
| | | [Number of months or km (miles), whichever occurs first] | | | | | | | | | | | | | | | | | |
| Months | | 3 | 7.5 | 15 | 22.5 | 30 | 37.5 | 45 | 52.5 | 60 | 67.5 | 75 | 82.5 | 90 | 97.5 | 105 | 112.5 | 120 | |
| × 1,000 km | | 4.8 | 12 | 24 | 36 | 48 | 60 | 72 | 81.4 | 96 | 108 | 120 | 132 | 144 | 156 | 168 | 180 | 192 | |
| × 1,000 miles | | 3 | 7.5 | 15 | 22.5 | 30 | 37.5 | 45 | 52.5 | 60 | 67.5 | 75 | 82.5 | 90 | 97.5 | 105 | 112.5 | 120 | |
| 1 | Engine oil | R | R | R | R | R | R | R | R | R | R | R | R | R | R | R | R | R | |
| 2 | Engine oil filter | R | R | R | R | R | R | R | R | R | R | R | R | R | R | R | R | R | |
| 3 | Spark plugs | | | | | R | | | | R | | | | R | | | | R | |
| | | | | | | | | | | R | | | | | | | | R | |
| 4 | Drive belt(s) | | | | | I | | | | I | | | | I | | R | | | |
| 5 | Camshaft Drive belt | | | | | I | | | | I | | | | I | | R | | For 2.5 L Note (1) | |
| 6 | Fuel line | | | | | (I) | | | | (I) | | | | (I) | | | | I | |
| 7 | Fuel filter | | | | | (R) | | | | (R) | | | | (R) | | | | R | |
| 8 | Air cleaner element | | | | | R | | | | R | | | | R | | | | R | |
| 9 | Cooling system | | | | | I | | | | I | | | | I | | | | I | |
| 10 | Coolant | | | | | R | | | | R | | | | R | | | | R | |
| 11 | Clutch system | | | I | | I | | I | | I | | I | | I | | I | | I | |
| 12 | Transmission oil | | | | | I | | | | I | | | | I | | | | I | |
| 13 | ATF | | | | | I | | | | I | | | | I | | | | I | |
| 14 | Front & rear differential oil | | | | | I | | | | I | | | | I | | | | I | |
| 15 | Brake line | | | I | | I | | I | | I | | I | | I | | I | | I | |
| 16 | Brake fluid | | | | | R | | | | R | | | | R | | | | R | |
| 17 | Disc brake pads & discs | | | | | I | | | | I | | | | I | | | | I | |
| 18 | Parking brake | | | I | | I | | I | | I | | I | | I | | I | | I | |
| 19 | Suspension | | | I | | I | | I | | I | | I | | I | | I | | I | |
| 20 | Wheel bearing | | | | | | | | | (I) | | | | | | | | (I) | |
| 21 | Axle boots & joints | | | I | | I | | I | | I | | I | | I | | I | | I | |
| 22 | Tire rotation | | I | I | I | I | I | I | I | I | I | I | I | I | I | I | I | I | |
| 23 | Steering system (Power steering) | | | I | | I | | I | | I | | I | | I | | I | | I | |
| 24 | Supplement restraint system | Inspect every 10 years. | | | | | | | | | | | | | | | | | |

SCHEDULE

PERIODIC MAINTENANCE SERVICES

Symbols used:

R: Replace

I: Inspection

(R) or (I): Recommended service for safe vehicle operation.

NOTE:

(1) Periodic inspection and replacement of the camshaft drive chains on the 3.0 liter models are not required.

(2) This inspection is not required to maintain emission warranty eligibility and it does not affect the manufacturer's obligations under EPA's in-use compliance program.

(3) When the vehicle is used in extremely dusty conditions, the air cleaner element should be replaced more often.

(4) ATF filter is maintenance free part. ATF filter needs replacement, when it has physically damaged or ATF leaked.

(5) A tire should be replaced when the tread wear indicator appears as a solid band across the tread. The indicators appear when the remaining tread has been worn to 1.6 mm (0.063 in) or less.

SCHEDULE

PERIODIC MAINTENANCE SERVICES

B: MAINTENANCE SCHEDULE 2

| Item | Every | Repeat short distance drive | Repeat rough/muddy road drive | Extremely cold weather area | Salt or other corrosive used or coastal area | High humidity or mountain area | Repeat towing trailer |
|----------------------------------|--------------|-----------------------------|-------------------------------|-----------------------------|--|--------------------------------|-----------------------|
| Engine oil | 3.75 months | R | | R | | | R |
| | 6,000 km | | | | | | |
| | 3,750 miles | | | | | | |
| Engine oil filter | 3.75 months | R | | R | | | R |
| | 6,000 km | | | | | | |
| | 3,750 miles | | | | | | |
| Fuel filter | 15 months | | | | I | | |
| | 24,000 km | | | | | | |
| | 15,000 miles | | | | | | |
| Fuel line | 15 months | | | | I | | |
| | 24,000 km | | | | | | |
| | 15,000 miles | | | | | | |
| Transmission oil | 15 months | | | | | | R |
| | 24,000 km | | | | | | |
| | 15,000 miles | | | | | | |
| ATF | 15 months | | | | | | R |
| | 24,000 km | | | | | | |
| | 15,000 miles | | | | | | |
| Front & rear differential oil | 15 months | | | | | | R |
| | 24,000 km | | | | | | |
| | 15,000 miles | | | | | | |
| Brake line | 15 months | I | I | | I | | I |
| | 24,000 km | | | | | | |
| | 15,000 miles | | | | | | |
| Brake fluid | 15 months | | | | | R | |
| | 24,000 km | | | | | | |
| | 15,000 miles | | | | | | |
| Disc brake pads & discs | 15 months | I | I | | I | | I |
| | 24,000 km | | | | | | |
| | 15,000 miles | | | | | | |
| Parking brake | 15 months | I | I | | I | | I |
| | 24,000 km | | | | | | |
| | 15,000 miles | | | | | | |
| Suspension | 7.5 months | | I | I | I | | I |
| | 12,000 km | | | | | | |
| | 7,500 miles | | | | | | |
| Axle boots & joints | 7.5 months | I | I | I | I | | I |
| | 12,000 km | | | | | | |
| | 7,500 miles | | | | | | |
| Steering system (Power steering) | 7.5 months | I | I | I | I | | I |
| | 12,000 km | | | | | | |
| | 7,500 miles | | | | | | |

ENGINE OIL

PERIODIC MAINTENANCE SERVICES

3. Engine Oil

A: REPLACEMENT

NOTE:

Replace engine oil and engine oil filter at the same time.

1) Drain engine oil by loosening engine oil drain plug.

2.5 L model

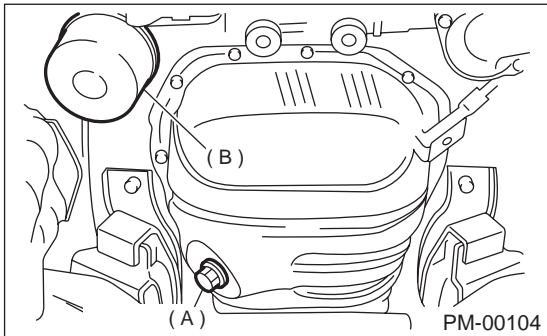

- (A) Drain plug
- (B) Oil filter

3.0 L model

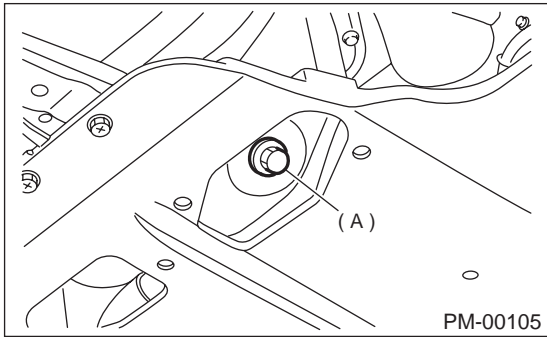

- (A) Drain plug

2) Open engine oil filler cap for quick draining of the engine oil.

2.5 L model

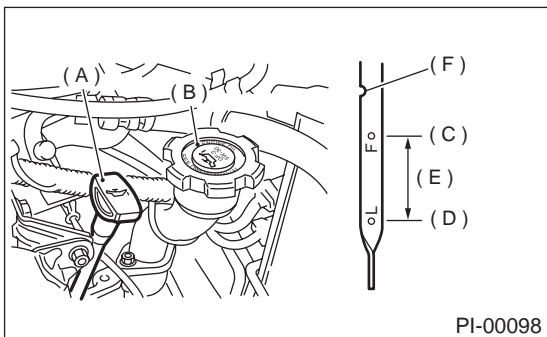

3.0 L model

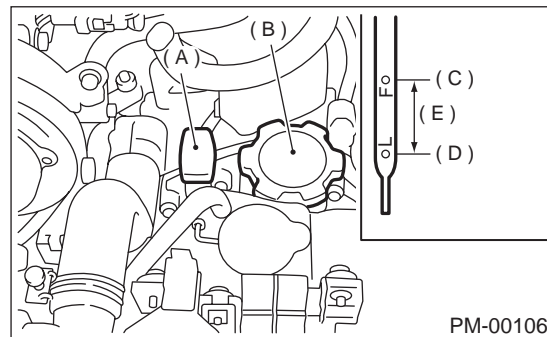

- (A) Oil level gauge
- (B) Engine oil filler cap
- (C) Upper level
- (D) Lower level
- (E) About 1.0 ℓ (1.1 US qt, 0.9 imp qt)
- (F) Notch

3) Replace drain plug gasket.

4) Tighten engine oil drain plug after draining engine oil.

Tightening torque:

44 N·m (4.5 kgf·m, 33 ft·lb)

5) Fill engine oil through filler pipe up to upper point on level gauge. Make sure that vehicle is placed level when checking oil level. Use engine oil of proper quality and viscosity, selected in accordance with the table in figure.

Engine oil amount for preparation:

2.5 L model

Approx. 4.0 ℓ (4.2 US qt, 3.5 Imp qt)

3.0 L model

Approx. 5.6 ℓ (5.9 US qt, 4.9 Imp qt)

| SAE Viscosity No. and Applicable Temperature | | | | | | | |
|--|-----------------|-----|-----|----|----|----|-----|
| (°C) | -30 | -20 | -15 | 0 | 15 | 30 | 40 |
| (°F) | -22 | -4 | 5 | 32 | 59 | 86 | 104 |
| | 10W-30, 10W-40 | | | | | | |
| | 5W-30 PREFERRED | | | | | | |

ENGINE OIL

PERIODIC MAINTENANCE SERVICES

The proper viscosity helps vehicle get good cold and hot starting by reducing viscous friction and thus increasing cranking speed.

NOTE:

- When replenishing oil, it does not matter if the oil to be added is a different brand from that in the engine; however, use oil having the ILSAC or API classification, and SAE viscosity No. designated by SUBARU.

- If vehicle is used in desert areas with very high temperatures or for other heavy duty applications, the following viscosity oils may be used:

API classification: SL

ILSAC classification: GF-3

SAE Viscosity No.: 30, 40, 10W-50, 20W-40, 20W-50

6) Close engine oil filler cap.

7) Start engine and warm it up for a time.

8) After engine stops, recheck the oil level.

If necessary, add engine oil up to upper level on level gauge.

2.5 L model

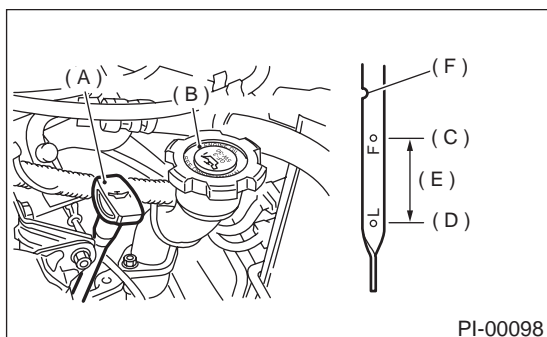

PI-00098

3.0 L model

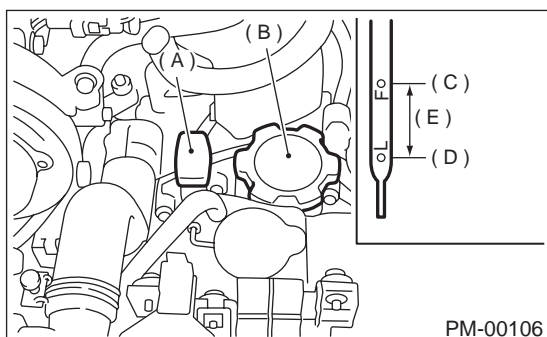

PM-00106

- (A) Oil level gauge
- (B) Engine oil filler cap
- (C) Upper level
- (D) Lower level
- (E) About 1.0 ℓ (1.1 US qt, 0.9 imp qt)
- (F) Notch mark

B: INSPECTION

- 1) Park vehicle on a level surface.
- 2) Remove oil level gauge and wipe it clean.
- 3) Reinsert the level gauge all the way. Be sure that the level gauge is correctly inserted and in the proper orientation.
- 4) Remove it again and note the reading. If the engine oil level is below the "L" line, add oil to bring the level up to the "F" line.
- 5) After turning off the engine, wait a few minutes for the oil to drain back into the oil pan before checking the level.
- 6) Just after driving or while the engine is warm, engine oil level may show in the range between the "F" line and the notch mark. This is caused by thermal expansion of the engine oil.
- 7) To prevent overfilling the engine oil, do not add oil above the "F" line when the engine is cold.

ENGINE OIL FILTER

PERIODIC MAINTENANCE SERVICES

4. Engine Oil Filter

A: REPLACEMENT

1. 2.5 L MODEL

- 1) Remove oil filter with ST.
ST 498547000 OIL FILTER WRENCH

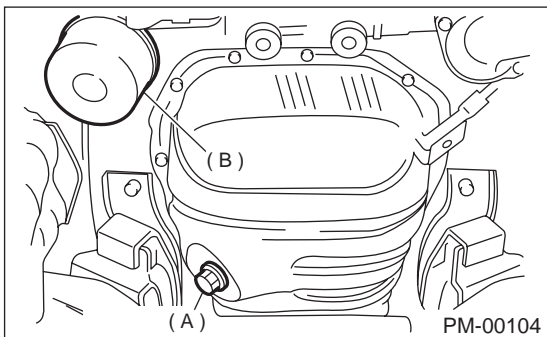

- (A) Drain plug
- (B) Oil filter

- 2) Get a new oil filter and apply a thin coat of engine oil to the seal rubber.
- 3) Install oil filter by turning it by hand, being careful not to damage seal rubber.
- 4) Tighten more (approximately 2/3 to 3/4 turn) after the seal rubber contacts the cylinder block. Do not tighten excessively, or oil may leak.
- 5) After installing oil filter, run engine and make sure that no oil is leaking around seal rubber.

NOTE:

The filter element and filter case are permanently joined; therefore, interior cleaning is not necessary.

- 6) Check the engine oil level. <Ref. to PM-6, Engine Oil.>

2. 3.0 L MODEL

- 1) Drain engine oil by loosening engine oil drain plug.

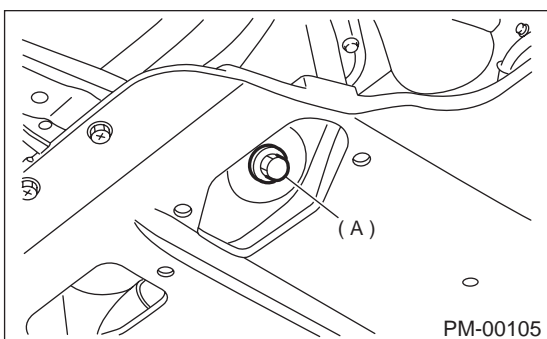

- (A) Drain plug

- 2) Remove access lid.

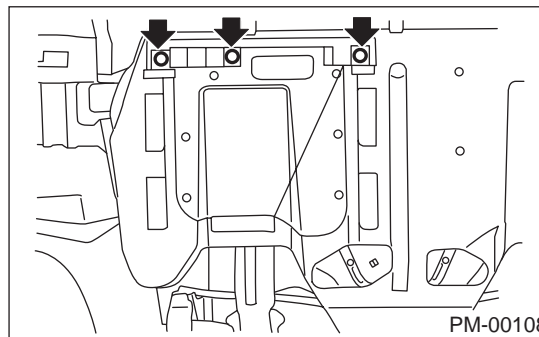

- 3) Remove oil filter with ST.
ST 498547000 OIL FILTER WRENCH

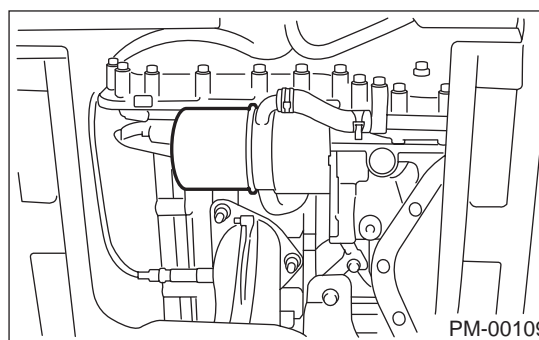

- 4) Get a new oil filter and apply a thin coat of engine oil to the rubber seal.
- 5) Install oil filter by turning it by hand, being careful not to damage rubber seal.
- 6) Tighten more (approximately 2/3 to 3/4 turn) after the rubber seal contacts the oil cooler. Do not tighten excessively, or oil may leak.
- 7) After installing oil filter, run engine and make sure that no oil is leaking around rubber seal.

NOTE:

The filter element and filter case are permanently joined; therefore, interior cleaning is not necessary.

- 8) Fill the engine oil. <Ref. to PM-6, Engine Oil.>

SPARK PLUGS

PERIODIC MAINTENANCE SERVICES

5. Spark Plugs

A: REPLACEMENT

1. 2.5 L MODEL

- 1) Disconnect battery ground cable.
- 2) Remove intake duct and intake chamber.
- 3) Remove washer tank and put it aside.
- 4) Disconnect spark plug cord.
- 5) Remove spark plug with a plug-wrench.

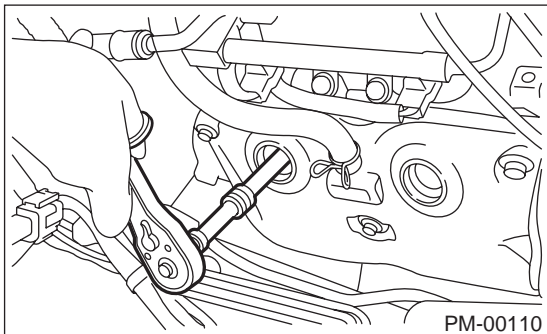

- 6) Set new spark plug.

Recommended spark plug:

CHAMPION RC10YC4

NGK BKR5E-11

NGK BKR6E-11

Spark plug gap

1.0 — 1.1 mm (0.039 — 0.043 in)

- 7) Tighten spark plug lightly with hand, and then secure with a plug-wrench to the specified torque.

Tightening torque:

21 N·m (2.1 kgf-m, 15 ft-lb)

NOTE:

- Be sure to place the gasket between the cylinder head and spark plug.
- If torque wrench is not available, tighten spark plug until gasket contacts cylinder head; then tighten further 1/4 to 1/2 turns.

2. 3.0 L MODEL

- 1) Disconnect battery cables and then remove battery and battery carrier.
- 2) Remove washer tank and put it aside.
- 3) Remove air cleaner lower case.
- 4) Disconnect connector from ignition coil.
- 5) Remove ignition coil.

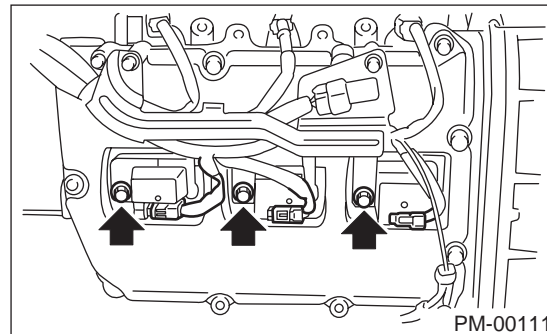

- 6) Remove spark plug with a spark plug socket.

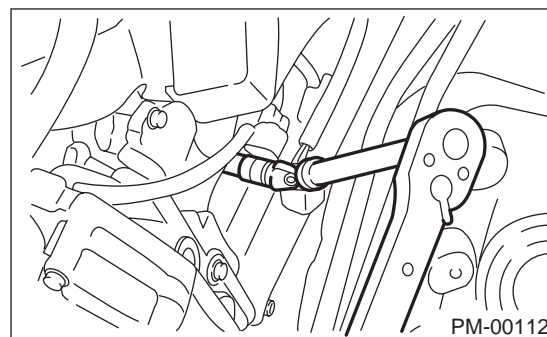

- 7) Set new spark plug.

Recommended spark plug:

NGK PLFR 6A-11

- 8) Tighten spark plug lightly with hand, and then secure with a plug-wrench to the specified torque.

Tightening torque:

21 N·m (2.1 kgf-m, 15 ft-lb)

- 9) Tighten ignition coil.

Tightening torque:

16 N·m (1.6 kgf-m, 11.7 ft-lb)

NOTE:

- Be sure to place the gasket between the cylinder head and spark plug.
- If torque wrench is not available, tighten spark plug until gasket contacts cylinder head; then tighten further 1/4 to 1/2 turn.

DRIVE BELT(S)

PERIODIC MAINTENANCE SERVICES

6. Drive Belt(s)

A: INSPECTION

1. 2.5 L MODEL

- 1) Replace belts, if cracks, fraying or wear is found.
- 2) Check drive belt tension and adjust it if necessary by changing generator installing position and/or idler pulley installing position.

Belt tension

(A)

replaced: 7.0 — 9.0 mm (0.276 — 0.354 in)

reused: 9.0 — 11.0 mm (0.354 — 0.433 in)

(B)*

replaced: 7.5 — 8.5 mm (0.295 — 0.335 in)

reused: 9.0 — 10.0 mm (0.354 — 0.394 in)

*: There is no belt (B) on models without an air conditioner.

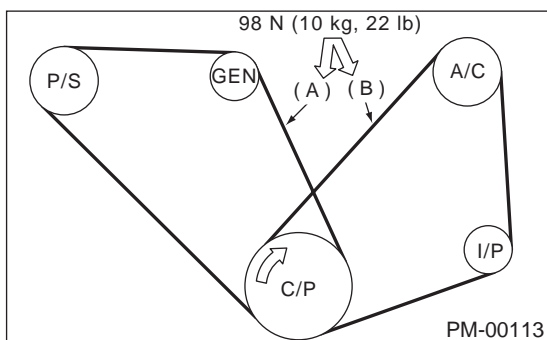

- C/P Crankshaft pulley
- GEN Generator
- P/S Power steering oil pump pulley
- A/C Air conditioning compressor pulley
- I/P Idler pulley

2. 3.0 L MODEL

- 1) Replace belts, if cracks, fraying or wear is found.
- 2) Check that the V-belt automatic tensioner indicator is within the range (D).

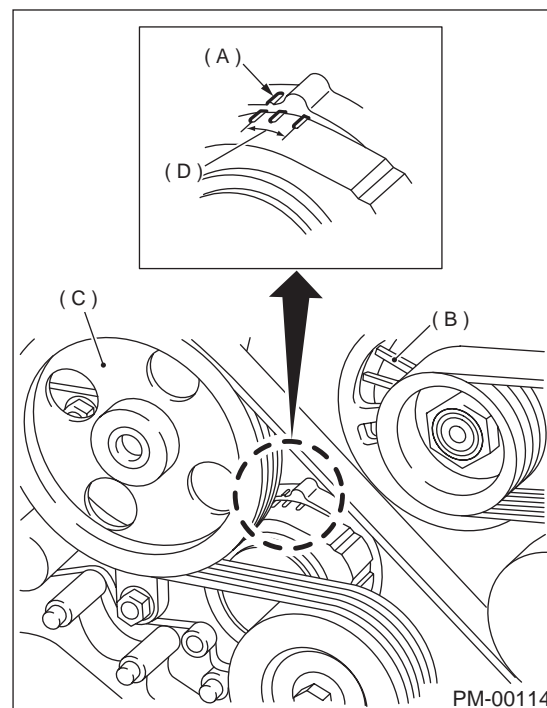

- (A) Indicator
- (B) Generator
- (C) Power steering oil pump
- (D) Service limit

DRIVE BELT(S)

PERIODIC MAINTENANCE SERVICES

B: REPLACEMENT

1. 2.5 L MODEL

- 1) Remove V-belt cover.

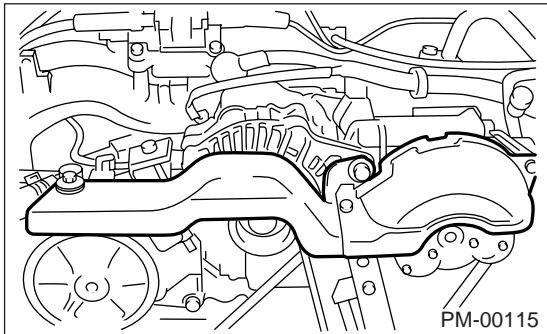

NOTE:

Wipe off any oil or water on the belt and pulley.

- 2) Loosen the lock bolt (A).
- 3) Loosen the slider bolt (B).
- 4) Remove the front side belt (C).

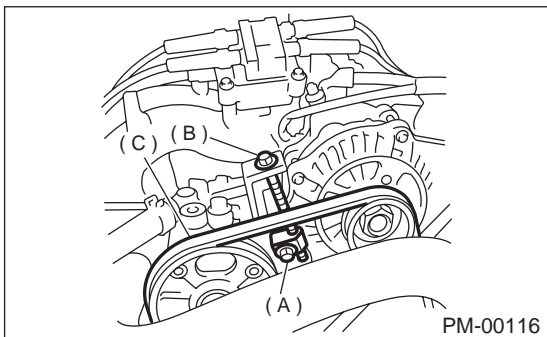

- 5) Loosen the lock nut (A).
- 6) Loosen the slider bolt (B).
- 7) Remove the rear side belt (C).

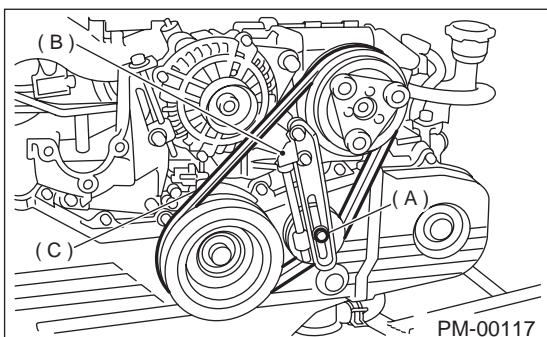

- 8) Install a new belt, and tighten the slider bolt so as to obtain the specified belt tension.
- 9) Tighten the slider bolt (B).

- 10) Tighten the lock nut (A).

Tightening torque:

22.6 N-m (2.3 kgf-m, 16.6 ft-lb)

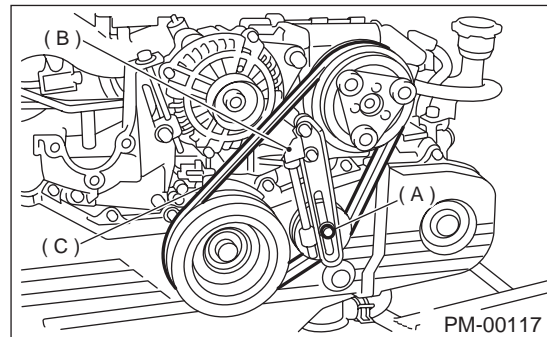

- 11) Install a new belt, and tighten the slider bolt so as to obtain the specified belt tension.

- 12) Tighten the lock bolt (A).
- 13) Tighten the slider bolt (B).

Tightening torque:

Lock bolt, through bolt:

25 N-m (2.5 kgf-m, 18 ft-lb)

Slider bolt:

8 N-m (0.8 kgf-m, 5.8 ft-lb)

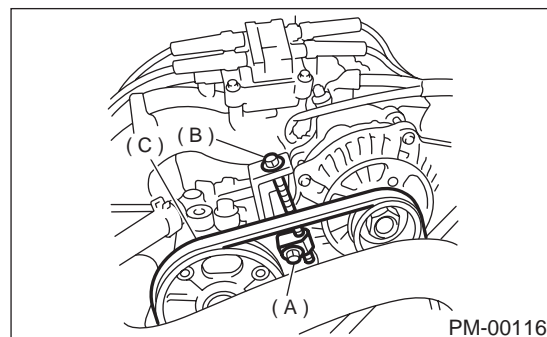

- 14) Install V-belt cover.

2. 3.0 L MODEL

- 1) Fit the tool to the belt tensioner mounting bolt.
- 2) Turn the tool clockwise, and loosen the V-belt to remove.

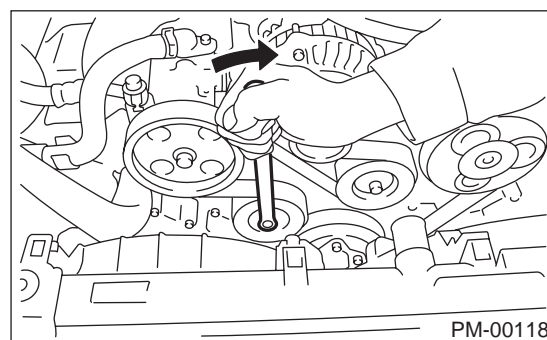

DRIVE BELT(S)

PERIODIC MAINTENANCE SERVICES

3) Install in the reverse order of removal.

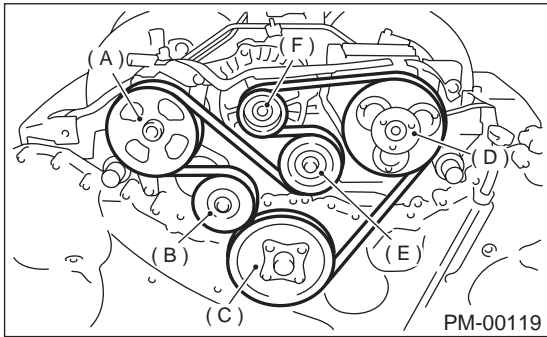

- (A) Power steering oil pump
- (B) Belt tension adjuster
- (C) Crankshaft pulley
- (D) A/C compressor
- (E) Belt idler
- (F) Generator

CAMSHAFT DRIVE BELT

PERIODIC MAINTENANCE SERVICES

7. Camshaft Drive Belt

A: REPLACEMENT

- 1) Remove radiator fan. <Ref. to CO(H4SO)-27, Radiator Main Fan and Fan Motor.> and <Ref. to CO(H4SO)-29, Radiator Sub Fan and Fan Motor.>
- 2) Remove V-belt cover.

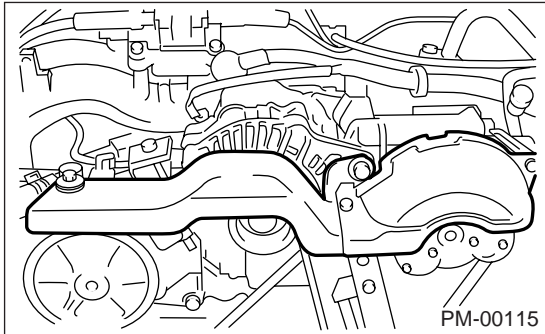

- 3) Remove V-belts. <Ref. to ME(H4SO)-42, V-belt.>
- 4) Remove air conditioning compressor drive belt tensioner.
- 5) Remove pulley bolt. To lock crankshaft use ST. ST 499977100 CRANKSHAFT PULLEY WRENCH

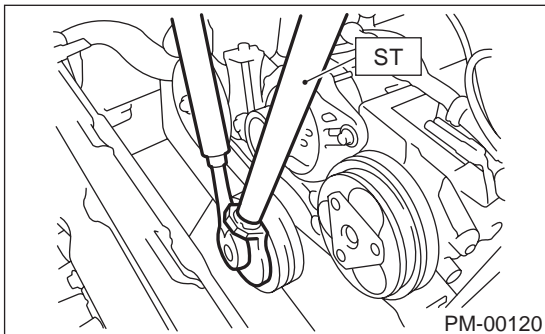

- 6) Remove crankshaft pulley.
- 7) Remove left side belt cover.
- 8) Remove front belt cover.

- 9) Turn crankshaft and align alignment marks on crankshaft, and left and right camshaft sprockets with notches of belt cover and cylinder block:
ST 499987500 CRANKSHAFT SOCKET

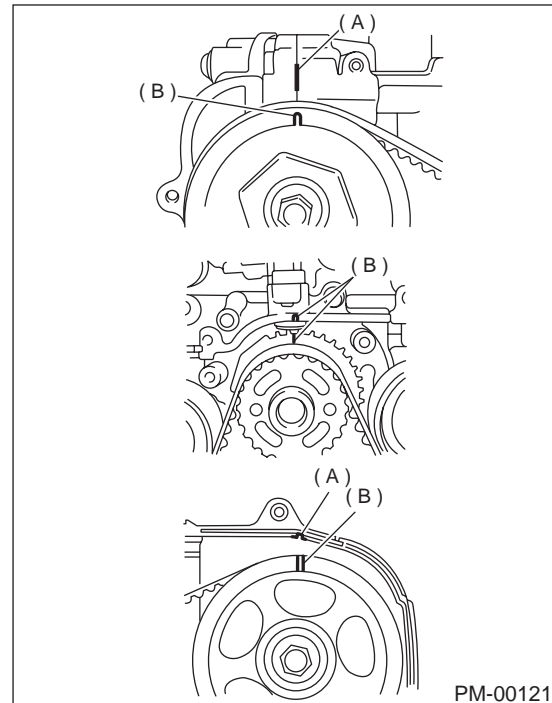

- (A) Notch
(B) Alignment mark

- 10) Remove belt idler.
- 11) Remove belt idler (No. 2).

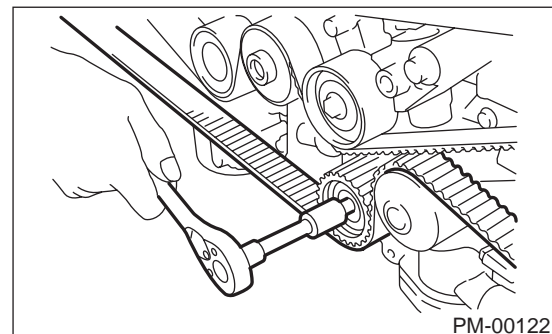

CAMSHAFT DRIVE BELT

PERIODIC MAINTENANCE SERVICES

- 12) Remove timing belt.
- 13) Remove automatic belt tension adjuster assembly.

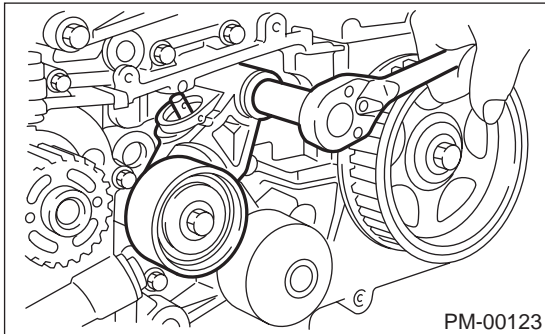

B: INSTALLATION

Install in the reverse order of removal.

NOTE:

When installing the timing belt, be sure to align all alignment marks on the belt with corresponding marks on the sprockets. If incorrectly installed, interference between pistons and valves may occur.

C: INSPECTION

- 1) Remove front timing belt cover and timing belt cover (LH).
- 2) While cranking engine at least four rotations, check timing belt back surface for cracks or damage. Replace faulty timing belt as needed.
- 3) Measure timing belt width W . If it is less than 27 mm (1.06 in), check idlers, tensioner, water pump pulley and cam sprocket to determine idler alignment (squareness). Replace worn timing belt.

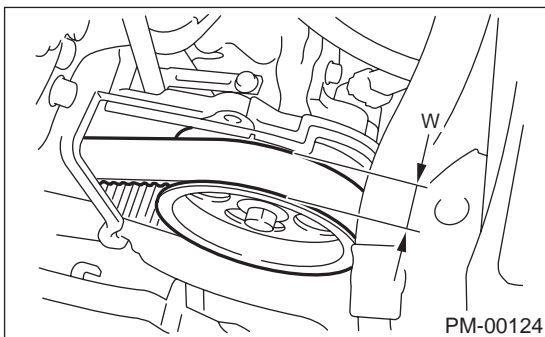

- 4) Install front timing belt cover and timing belt cover (LH).

8. Fuel Line**A: INSPECTION**

The fuel line is located mostly internally, so check pipes, areas near pipes, and engine compartment piping for rust, hose damage, loose bands, etc. If faulty parts are found, repair or replace them. <Ref. to FU(H4SO)-76, Fuel Delivery, Return and Evaporation Lines.> or <Ref. to FU(H6DO)-78, Fuel Delivery, Return and Evaporation Lines.>

FUEL FILTER

PERIODIC MAINTENANCE SERVICES

9. Fuel Filter

A: REPLACEMENT

WARNING:

- Place “No fire” signs near the working area.
- Disconnect ground cable from battery.

CAUTION:

Be careful not to spill fuel on the floor.

- 1) Before removing the hose, filter, pump, etc., be sure to release the fuel pressure, as follows:
 - Disconnect the fuel pump relay.
 - Crank the engine for more than five seconds. If the engine starts, let the engine run until it stops.
 - After turning ignition switch OFF, connect the fuel pump relay.
 - Disconnect ground cable from battery.
- 2) Loosen the screw of the hose clamp and pull off the hose from the filter.
- 3) Remove the filter from the holder.
- 4) Replace fuel filter with a new one.

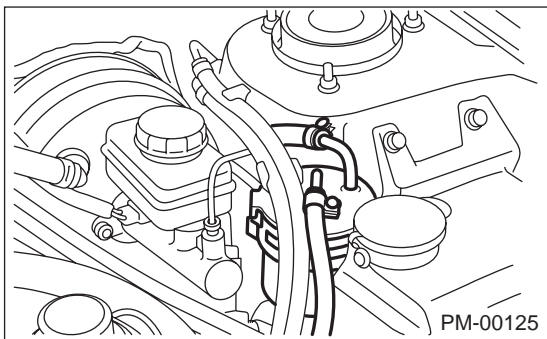

- 5) Install the hoses.
<Ref. to FU(H4SO)-76, Fuel Delivery, Return and Evaporation Lines.> or <Ref. to FU(H6DO)-78, Fuel Delivery, Return and Evaporation Lines.>

Tightening torque:

1.5 N·m (0.15 kgf-m, 1.1 ft-lb)

B: INSPECTION

- 1) If clogged or exceeds the service limit for replacement, replace the fuel filter.
- 2) If water remains, shake the fuel filter to drain.

AIR CLEANER ELEMENT

PERIODIC MAINTENANCE SERVICES

10. Air Cleaner Element

A: REPLACEMENT

1. 2.5 L MODEL

Do not attempt to clean the air cleaner element. The filter paper of the element is wetted with a special non-inflammable slow-evaporating viscous liquid. It is resistant to cold weather and has a long service life. Dirt adhering to this filter paper forms porous laminations with the viscous liquid, which function as a filtration layer to reduce dust penetration into the filter paper. If this filter paper is cleaned, the filtration layer thus formed will be lost along with the viscous liquid.

- 1) Remove the air intake duct from air cleaner case.
- 2) Remove the bolt (A) which installs air cleaner case to stays.
- 3) Remove the clip (B) above the air cleaner case.

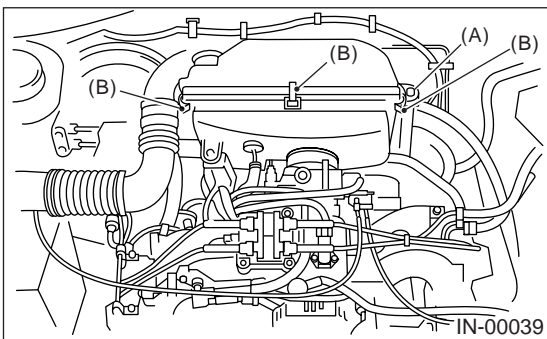

- 4) Remove the air cleaner element.

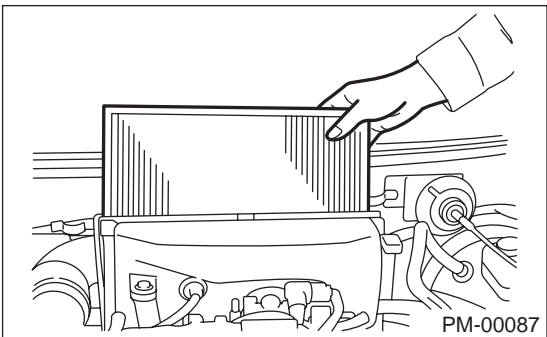

- 5) Install in the reverse order of removal.

CAUTION:

Fasten with a clip after inserting the lower tab of the case.

2. 3.0 L MODEL

Do not attempt to clean the air cleaner element. The filter paper of the element is wetted with a special non-flammable slow-evaporating viscous liquid. It is resistant to cold weather and has a long service life. Dirt adhering to this filter paper forms porous laminations with the viscous liquid, which function as a filtration layer to reduce dust penetration into the filter paper. If this filter paper is cleaned, the filtration layer thus formed will be lost along with the viscous liquid.

- 1) Loosen clamp (A), and separate air cleaner upper cover and air intake boot.
- 2) Remove the clip (B) above the air cleaner upper cover.

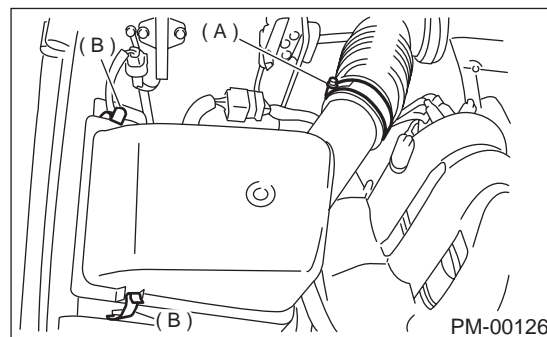

- 3) Remove air cleaner element.
- 4) Install in the reverse order of removal.

CAUTION:

Before installing air cleaner upper cover, align holes with protruding portions of air cleaner lower case, then secure upper cover to lower case.

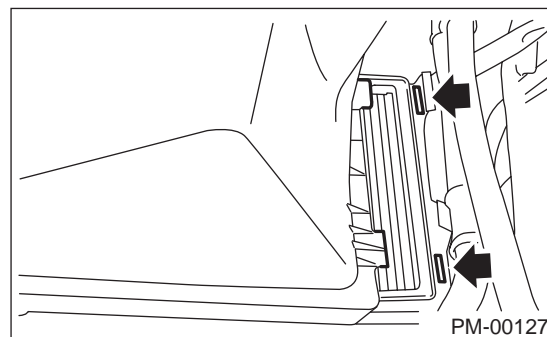

COOLING SYSTEM

PERIODIC MAINTENANCE SERVICES

11. Cooling System

A: INSPECTION

1) Check radiator for leakage, filling it with coolant and attach radiator cap tester (A) to the filler neck. Then apply a pressure of 157 kPa (1.6 kg/cm², 23 psi) and check the following points:

- Each portion of radiator for leakage
- Hose joints and other connections for leakage

NOTE:

• When attaching or detaching tester and when operating tester, use special care not to deform radiator filler neck.

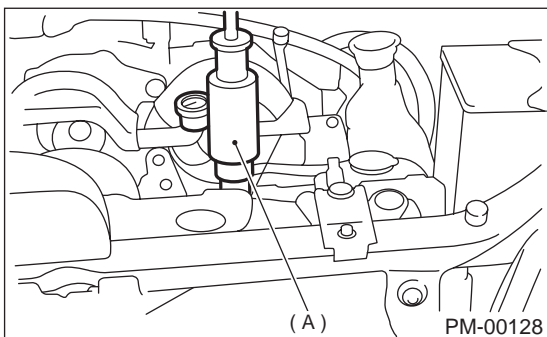

- When performing this check, be sure to keep the engine stationary and fill radiator with coolant.
- Wipe off check points before applying pressure.
- Use care not to spill coolant when detaching tester from radiator.

2) Check the radiator cap valve open pressure using radiator cap tester.

NOTE:

Rust or dirt on cap may prevent valve from functioning normally: be sure to clean cap before testing.

Raise the pressure until the needle of gauge stops and see if the pressure can be retained for five to six seconds. The radiator cap is normal if a pressure above the service limit value has been maintained for this period.

Radiator cap valve open pressure

Standard value:

93 — 123 kPa (0.95 — 1.25 kg/cm², 14 — 18 psi)

Service limit:

83 kPa (0.85 kg/cm², 12 psi)

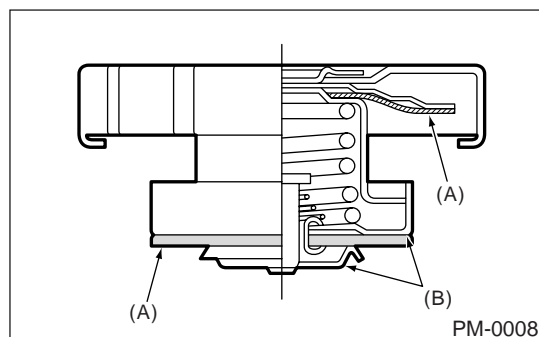
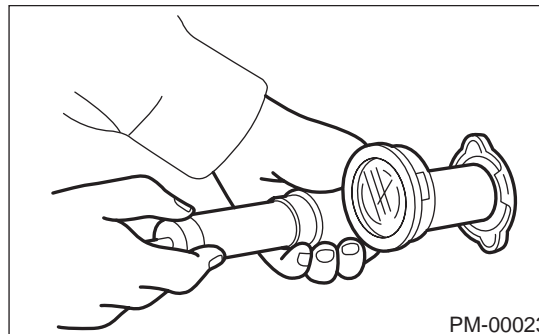

- (A) Check position for deformation
- (B) Check position for deformation, damage and rust.

3) If the coolant temperature exceeds 76.0 to 80.0°C (169 to 176°F) while radiator is not so hot, check thermostat. If thermostat does not open at 76.0 to 80.0°C (169 to 176°F), replace it with a new one.

4) If electric fan does not operate when coolant temperature exceeds 95°C (203°F), check the electric fan system.

COOLANT

PERIODIC MAINTENANCE SERVICES

12. Coolant

A: REPLACEMENT

1. REPLACEMENT OF COOLANT

WARNING:

The radiator is of the pressurized type. Do not attempt to open the radiator cap immediately after the engine has been stopped.

- 1) Lift up the vehicle.
- 2) Remove under cover.
- 3) Place a container under drain pipe.
- 4) Loosen and remove drain screw to drain engine coolant into container.

2.5 L model

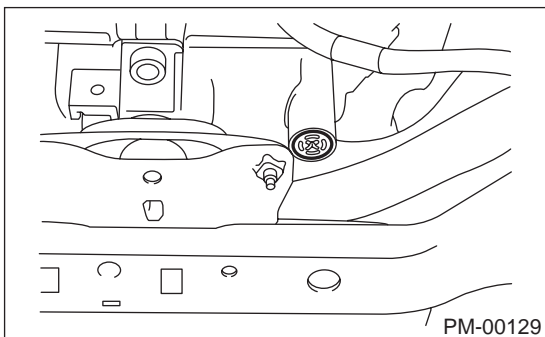

3.0 L model

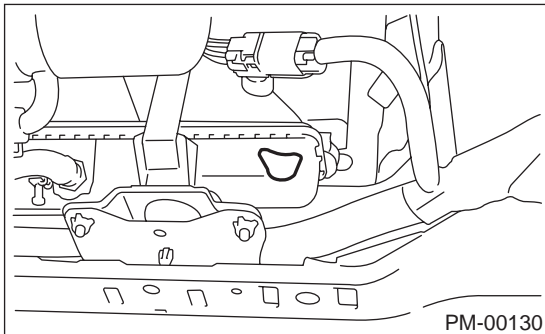

- 5) For quick draining, open radiator cap.

CAUTION:

Be careful not to spill coolant on the floor.

- 6) Drain coolant from reservoir tank.
- 7) Tighten radiator drain screw securely after draining coolant.

- 8) Slowly pour prepared coolant from radiator filler port to neck of filler, then pour into reservoir tank up to "FULL" level.

Coolant amount for preparation

2.5 L model

MT model:

Approx. 6.8 ℓ (7.2 US qt, 6.0 Imp qt)

AT model:

Approx. 6.7 ℓ (7.1 US qt, 5.9 Imp qt)

3.0 L model

Approx. 7.9 ℓ (8.4 US qt, 7.0 Imp qt)

NOTE:

The SUBARU Genuine Coolant containing anti-freeze and anti-rust agents is especially made for SUBARU engine, which has an aluminum crank-case. Always use SUBARU Genuine Coolant, since other coolant may cause corrosion.

- 9) Securely install radiator cap.

10) Run engine for more than five minutes at 2,000 to 3,000 rpm. (Run engine until radiator becomes hot in order to purge air trapped in cooling system.)

11) Stop engine and wait until coolant temperature lowers. Then open radiator cap to check coolant level and add coolant up to radiator filler neck. Next, add coolant into reservoir tank up to "FULL" level.

12) After adding coolant, securely install radiator and reservoir tank caps.

COOLANT

PERIODIC MAINTENANCE SERVICES

2. RELATIONSHIP OF SUBARU COOLANT CONCENTRATION AND FREEZING TEMPERATURE

The concentration and safe operating temperature of the SUBARU coolant is shown in the diagram. Measuring the temperature and specific gravity of the coolant will provide this information.

[Example]

If the coolant temperature is 25°C (77°F) and its specific gravity is 1.054, the concentration is 35% (point A), the safe operating temperature is -14°C (7°F) (point B), and the freezing temperature is -20°C (-4°F) (point C).

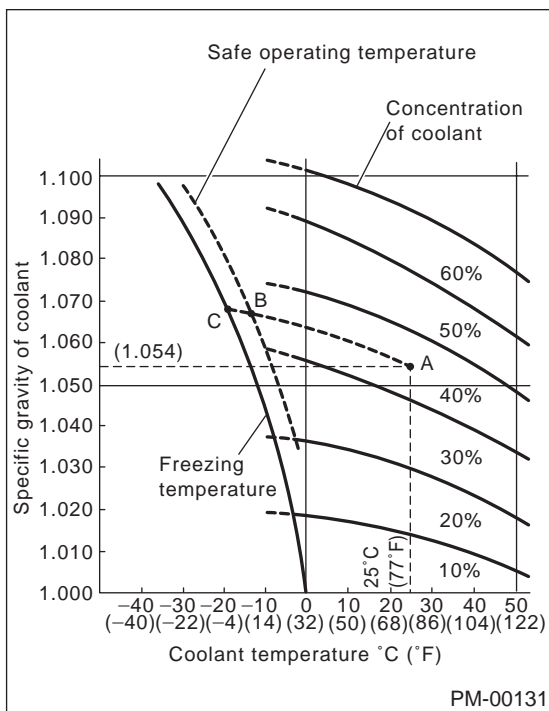

3. PROCEDURE TO ADJUST THE CONCENTRATION OF THE COOLANT

To adjust the concentration of the coolant according to temperature, find the proper fluid concentration in the above diagram and replace the necessary amount of coolant with an undiluted solution of SUBARU genuine coolant (concentration 50).

The amount of coolant that should be replaced can be determined using the diagram.

[Example]

Assume that the coolant concentration must be increased from 25% to 40%. Find point A, where the 25% line of coolant concentration intersects with the 40% curve of the necessary coolant concentration, and read the scale on the vertical axis of the graph at height A. The quantity of coolant to be drained is 2.1 liters (2.2 US qt, 1.8 Imp qt). Drain 2.1 liters (2.2 US qt, 1.8 Imp qt) of coolant from the cooling system and add 2.1 liters (2.2 US qt, 1.8 Imp qt) of the undiluted solution of SUBARU coolant.

If a coolant concentration of 50% is needed, drain all the coolant and refill with the undiluted solution only.

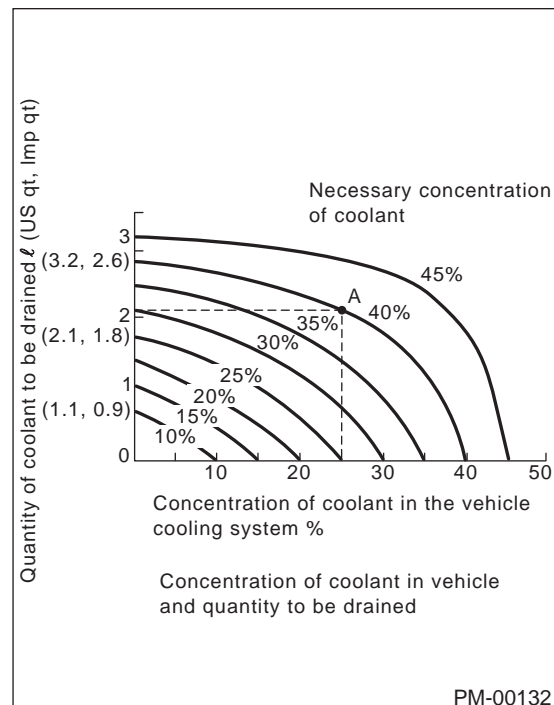

CLUTCH SYSTEM

PERIODIC MAINTENANCE SERVICES

13. Clutch System

A: INSPECTION AND ADJUSTMENT

1) Push the release lever to retract the push rod of the operating cylinder and check if the fluid level in the clutch reservoir tank rises or not.

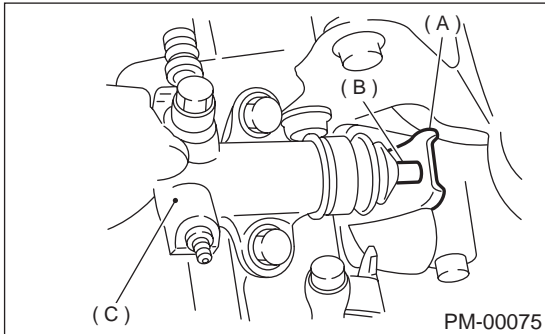

- (A) Release lever
- (B) Push rod
- (C) Operating cylinder

2) If the fluid level rises, pedal free play is correct.
3) If the fluid level does not rise, or the push rod cannot be retracted, adjust the clutch pedal. <Ref. to CL-21, Clutch Pedal.>
4) Inspect the underside of master cylinder, clutch damper and operating cylinder for clutch system, hoses, piping and their couplings for fluid leaks. If fluid leaks are found, correct them by retightening their fitting bolt and/or replacing their parts.

5) Check the fluid level using the scale on the outside of the clutch master cylinder tank (A). If the level is below "MIN" (B), add clutch fluid to bring it up to "MAX" (C).

Recommended clutch fluid:

FMVSS No. 116, fresh DOT3 or DOT4 brake fluid

NOTE:

- Avoid mixing different grades of brake fluid to prevent degradation of the fluid.
- Be careful not to allow dirt or dust to get into the reservoir tank.

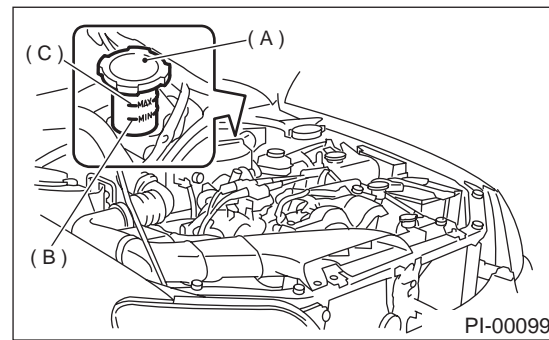

- (A) Reservoir tank
- (B) MIN. level
- (C) MAX. level

TRANSMISSION OIL

PERIODIC MAINTENANCE SERVICES

14. Transmission Oil

A: REPLACEMENT

1. MANUAL TRANSMISSION

1) Drain gear oil by removing drain plug after allowing the engine to cool for 3 to 4 hours.

NOTE:

- Before starting work, cool off the engine well.
- If transmission gear oil splashes on exhaust pipe, wipe it clean.

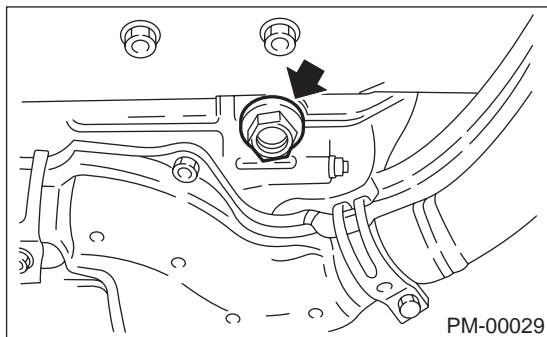

2) Reinstall drain plug after draining gear oil and tighten it to the specified torque.

Tightening torque:

44 N·m (4.5 kgf·m, 32.5 ft·lb)

NOTE:

- Replace the gasket with a new one.
- Each oil manufacturer has its base oil and additives. Thus, do not mix two or more brands.

3) Fill transmission gear oil through the oil level gauge hole up to the upper point of level gauge.

Gear oil capacity:

3.5 ℓ (3.7 US qt, 3.1 Imp qt)

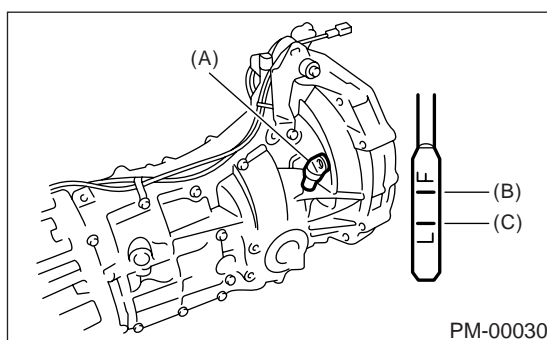

- (A) Oil level gauge
- (B) Upper level
- (C) Lower level

15.ATF

A: INSPECTION

1) Raise ATF temperature to 60 to 80°C (140 to 176°F) from 40 to 60°C (104 to 140°F) (when cold) by driving a distance of 5 to 10 km (3 to 6 miles).

NOTE:

The level of ATF varies with fluid temperature. Pay attention to the fluid temperature when checking oil level.

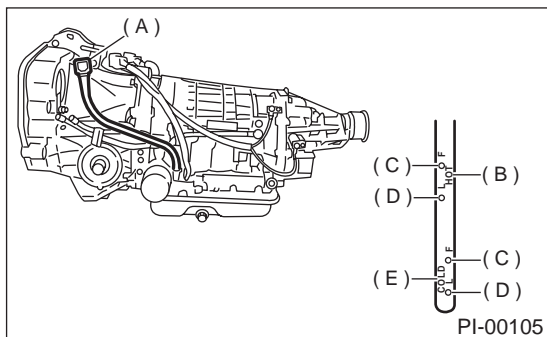

- (A) Level gauge
- (B) Check line, HOT condition
- (C) Upper level
- (D) Lower level
- (E) Check line, COLD condition

2) Make sure the vehicle is level. After selecting all positions (P, R, N, D, 3, 2, 1), set the select lever in "P" range. Measure fluid level with the engine idling.

NOTE:

After running, idle the engine for one or two minutes before measurement.

3) If the fluid level is below the center between upper and lower marks, add the recommended ATF until the fluid level is found within the specified range (above the center between upper and lower marks). When the transmission is hot, the level should be above the center of upper and lower marks, and when it is cold, the level should be found below the center of these two marks.

CAUTION:

- Use care not to exceed the upper limit level.
- ATF level varies with temperature. Remember that the addition of fluid to the upper limit mark when the transmission is cold will result in the overfilling of fluid.

4) Fluid temperature rising speed

- By idling the engine

Time for temperature rise to 60°C (140°F) with atmospheric temperature of 0°C (32°F): More than 25 minutes

<Reference>

Time for temperature rise to 30°C (86°F) with atmospheric temperature of 0°C (32°F): Approx. 8 minutes

- By running the vehicle

Time for temperature rise to 60°C (140°F) with atmospheric temperature of 0°C (32°F): More than 10 minutes

5) Method for checking fluid level upon delivery or at periodic inspection

Check fluid level after a warm-up run of approx. 10 minutes. During the warm-up period, the automatic transmission functions can also be checked.

ATF

PERIODIC MAINTENANCE SERVICES

B: REPLACEMENT

1. AUTOMATIC TRANSMISSION FLUID

1) Drain ATF (Automatic Transmission Fluid) by removing drain plug after allowing the engine to cool for 3 to 4 hours.

NOTE:

Before starting work, cool off the engine well.

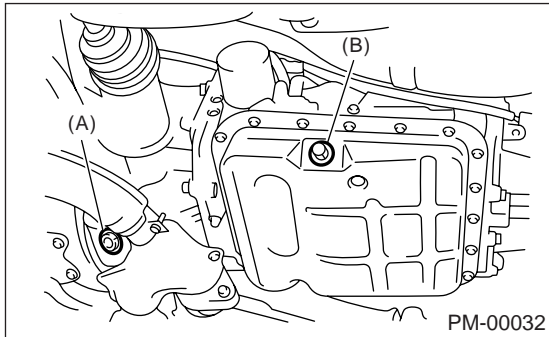

(A) Front differential drain plug

(B) ATF drain plug

2) Reinstall drain plug after draining ATF, and tighten it to the specified torque.

Tightening torque:

25 N·m (2.5 kgf-m, 18.1 ft-lb)

3) Pour ATF into the oil charge pipe.

Recommended fluid:

Dexron III type automatic transmission fluid

ATF amount:

Refill with the same amount of ATF that was drained.

4) Check the level of the ATF. Refer to "INSPECTION".

2. ATF FILTER

NOTE:

ATF filter is maintenance free part. ATF filter needs replacement, when it has physically damaged or ATF leaked.

For the replacement procedures of the ATF filter:
<Ref. to AT-73, ATF Filter.>

FRONT & REAR DIFFERENTIAL OIL

PERIODIC MAINTENANCE SERVICES

16. Front & Rear Differential Oil

A: REPLACEMENT

1. FRONT DIFFERENTIAL (MANUAL TRANSMISSION)

For M/T vehicle, manual transmission oil works as differential oil to lubricate differential. Refer to "Transmission Oil". <Ref. to PM-22, MANUAL TRANSMISSION, REPLACEMENT, Transmission Oil.>

2. FRONT DIFFERENTIAL (AUTOMATIC TRANSMISSION)

1) Drain differential gear oil by removing drain plug after allowing the engine to cool for 3 to 4 hours.

NOTE:

- Before starting work, cool off the engine well.
- If transmission gear oil splashes on exhaust pipe, wipe it clean.

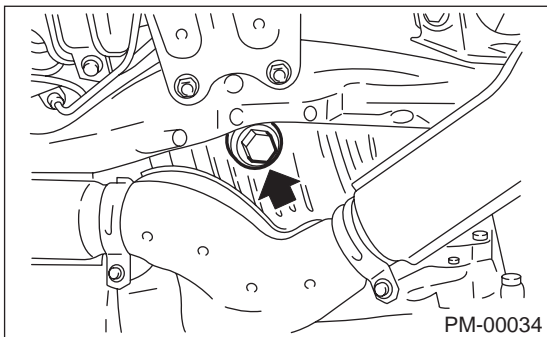

2) Reinstall drain plug after draining differential gear oil and tighten it to the specified torque.

Tightening torque:

44 N·m (4.5 kgf·m, 32.5 ft·lb)

NOTE:

- Be sure to place a gasket between the transmission case and drain plug.
 - Replace the gasket with a new one.
 - Each oil manufacturer has its base oil and additives. Thus, do not mix two or more brands.
- 3) Fill differential gear oil through the oil level gauge hole up to the upper point of level gauge.

Differential gear oil capacity:

1.1 — 1.3 ℓ (1.2 — 1.4 US qt, 1.0 — 1.1 Imp qt)

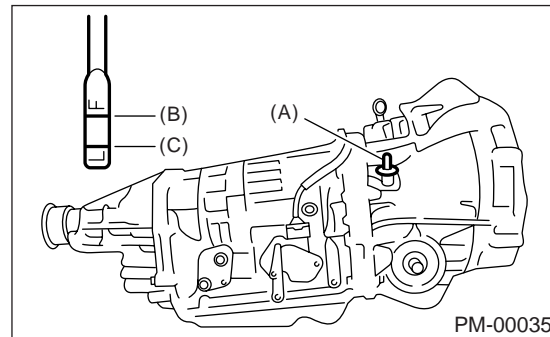

- (A) Oil level gauge
- (B) Upper level
- (C) Lower level

FRONT & REAR DIFFERENTIAL OIL

PERIODIC MAINTENANCE SERVICES

3. REAR DIFFERENTIAL

• L and BRIGHTON AT model

- 1) Drain oil by removing drain plug.
- 2) Remove filler plug for quicker draining.
- 3) Replace drain plug gasket with a new one.
- 4) Tighten drain plug to the specified torque.

Tightening torque:

34 N·m (3.5 kgf-m, 25.3 ft-lb)

- 5) After installing drain plug, fill oil fully up to the mouth of filler plug.

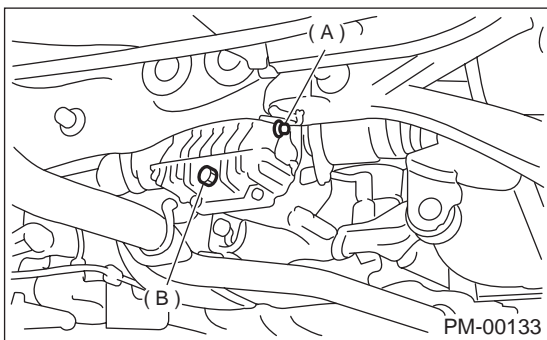

- (A) Filler plug
(B) Drain plug

Oil capacity:

0.9 ℓ (1.0 US qt, 0.8 Imp qt)

- 6) Replace filler plug gasket with a new one.
- 7) Install filler plug onto rear differential gear case.

Tightening torque:

34 N·m (3.5 kgf-m, 25.3 ft-lb)

• Except L and BRIGHTON AT model

- 1) Drain oil by removing drain plug.
- 2) Remove filler plug for quicker draining.
- 3) Tighten drain plug after draining oil.

NOTE:

Apply fluid packing to drain plug threads before installation.

Fluid packing:

Three Bond 1105 (Part No. 004403010)

Tightening torque:

49.0 N·m (5.0 kgf-m, 36.2 ft-lb)

- 4) After installing drain plug onto rear differential gear case firmly, fill oil up fully to the mouth of filler plug.

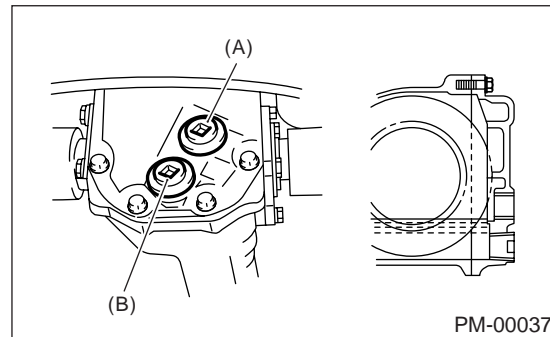

- (A) Filler plug
(B) Drain plug

Oil capacity:

0.8 ℓ (0.8 US qt, 0.7 Imp qt)

NOTE:

Each oil manufacturer has its base oil and additives. Thus, do not mix two or more brands.

- 5) Install filler plug onto rear differential gear case firmly.

NOTE:

Apply fluid packing to filler plug before installation.

Fluid packing:

Three Bond 1105 (Part No. 004403010)

Tightening torque:

49.0 N·m (5.0 kgf-m, 36.2 ft-lb)

BRAKE LINE

PERIODIC MAINTENANCE SERVICES

17.Brake Line

A: INSPECTION

1. BRAKE LINE

1) Check scratches, swelling, corrosion and/or traces of fluid leakage on brake hoses or pipe joints.

2) Check the possibility of adjacent parts interfering with brake pipes/hoses during driving, and loose connections/clamps.

3) Check any trace of fluid leakage, scratches, etc. on master cylinder, wheel cylinder and pressure control valve.

NOTE:

- When the brake fluid level in the reservoir tank is lower than the specified limit, the brake fluid warning light on the combination meter will come on.
- Visually check brake hose (using a mirror where it is difficult to see) for any damage.

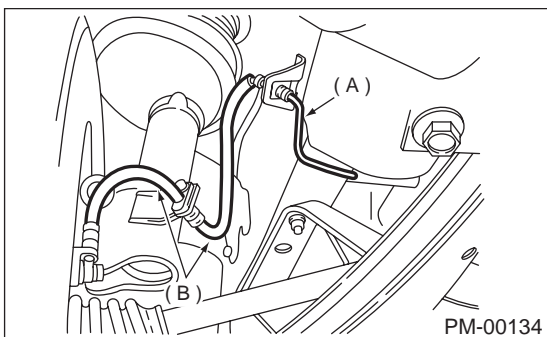

- (A) Front brake pipe
(B) Front brake hose

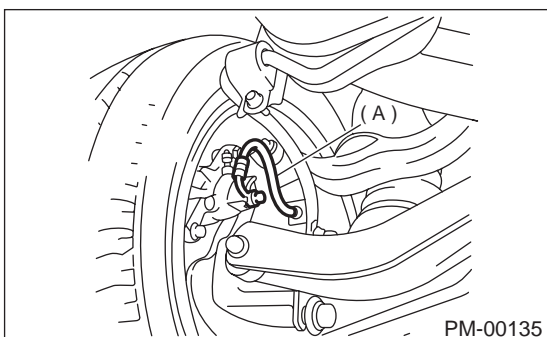

- (A) Rear brake hose

B: CHECKING

1. SERVICE BRAKE

1) Check the free play of brake pedal with a force of less than 10 N (1 kgf, 2 lb).

Brake pedal free play:

1 — 3 mm (0.04 — 0.12 in)

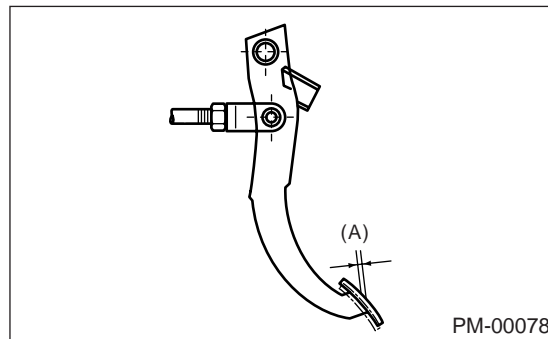

- (A) Pedal play

2) If the free play is out of specifications above, adjust the brake pedal as follows:

- (1) Be sure engine is off. (No vacuum is applied to brake booster.)
- (2) There should be play between brake booster clevis and pin at brake pedal installing portion.

[Depress brake pedal pad with a force of less than 10 N (1 kgf, 2 lb) to a stroke of 1 to 3 mm (0.04 to 0.12 in).]

- (3) Depress the surface of brake pad by hand.

BRAKE LINE

PERIODIC MAINTENANCE SERVICES

(4) If there is no free play between clevis pin and clevis, turn brake switch adjusting nut until the clearance between stopper and screw of brake switch becomes 0.3 mm (0.012 in).

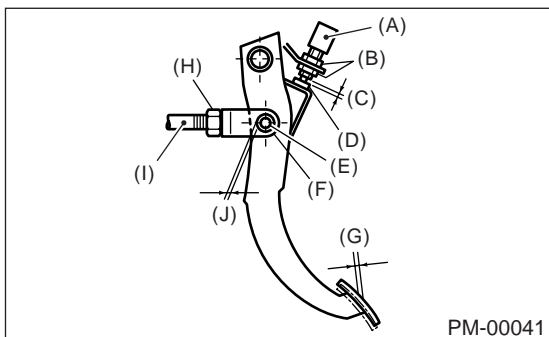

- (A) Brake switch
- (B) Adjusting nut
- (C) 0.3 mm (0.012 in)
- (D) Stopper
- (E) Clevis pin
- (F) Clevis
- (G) Pedal play
1 - 3 mm (0.04 - 0.12 in)
- (H) Lock nut
- (I) Brake booster operating nut
- (J) Play at pin

3) Check the pedal stroke.

While the engine is idling, depress the brake pedal with a 490 N (50 kgf, 110 lb) load and measure the distance between the brake pedal and steering wheel. With the brake pedal released, measure the distance between the pedal and steering wheel again. The difference between the two measurements must be less than 95 mm (3.74 in). If the distance is more than specified, there is a possibility air is in the inside of the hydraulic unit.

Brake pedal reserve distance: A
more than 95 mm (3.74 in)/ 490 N (50 kgf, 110 lb)

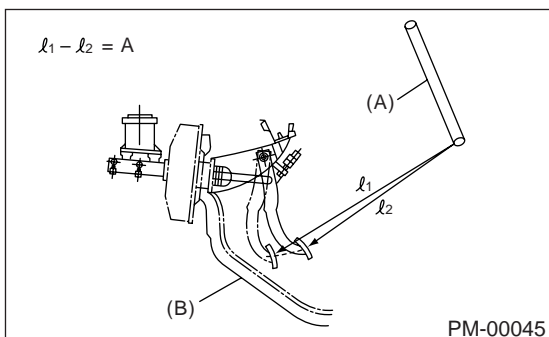

- (A) Steering wheel
- (B) Toe board

4) Check to see if air is in the hydraulic brake line by the feel of pedal operation. If air appears to exist in the line, bleed it from the system.

5) Check for even operation of all brakes, using a brake tester or by driving the vehicle for a short distance on a straight road.

2. BRAKE SERVO SYSTEM

1) With the engine off, depress the brake pedal several times applying the same pedal force: Make sure the travel distance should not change.

2) With the brake pedal depressed, start the engine: Make sure the pedal should move slightly toward the floor.

3) With the brake pedal depressed, stop the engine and keep the pedal depressed for 30 seconds: Make sure the pedal height should not change.

4) Check valve is built into vacuum hose. Disconnect vacuum hose to inspect function of check valve.

Blow air into vacuum hose from its brake booster side end: Air must flow out of engine side end of hose. Next blow air into hose from engine side: Air should not flow out of hose.

Replace both check valve and vacuum hose if check valve is faulty. Engine side of vacuum hose is indicated by marking "ENGINE" as shown.

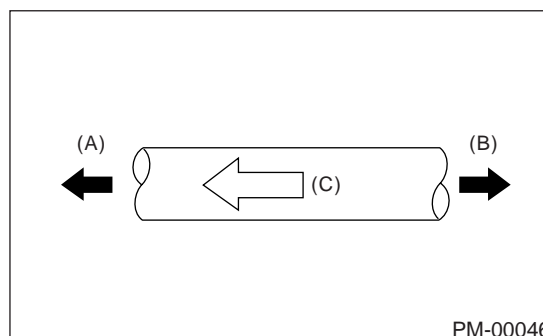

- (A) Engine side
- (B) Brake booster side
- (C) ENG

5) Check vacuum hose for cracks or other damage.

NOTE:

When installing the vacuum hose on the engine and brake booster, do not use soapy water or lubricating oil on their connections.

6) Check vacuum hose to make sure it is tight and secure.

18.Brake Fluid

A: REPLACEMENT

- 1) Either jack up vehicle and place a safety stand under it, or lift up vehicle.
- 2) Remove both front and rear wheels.
- 3) Draw out the brake fluid from master cylinder with syringe.
- 4) Refill reservoir tank with recommended brake fluid.

Recommended brake fluid:
FMVSS No. 116, fresh DOT3 or 4 brake fluid

NOTE:

- Avoid mixing different brands of brake fluid to prevent degrading the quality of the fluid.
- Be careful not to allow dirt or dust to get into the reservoir tank.

Bleeding sequence (1) → (2) → (3) → (4)

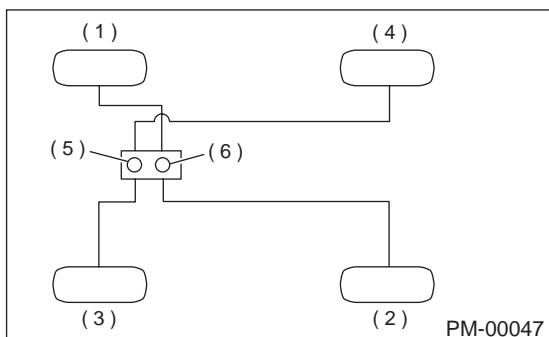

- (1) Front right
- (2) Rear left
- (3) Front left
- (4) Rear right
- (5) Secondary
- (6) Primary

5) Install one end of a vinyl tube onto the air bleeder and insert the other end of the tube into a container to collect the brake fluid.

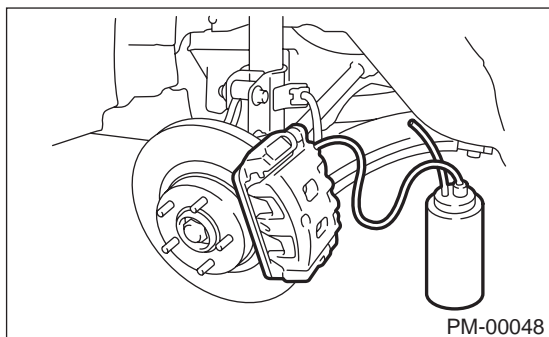

NOTE:

- Cover bleeder with waste cloth, when loosening it, to prevent brake fluid from being splashed over surrounding parts.
 - During bleeding operation, keep the brake reservoir tank filled with brake fluid to eliminate entry of air.
 - Brake pedal operation must be very slow.
 - For convenience and safety, it is advisable to have two men working.
 - The amount of brake fluid required is approximately 500 ml (16.9 US fl oz, 17.6 Imp fl oz) for total brake system.
- 6) Instruct your co-worker to depress the brake pedal slowly two or three times and then hold it depressed.
 - 7) Loosen bleeder screw approximately 1/4 turn until a small amount of brake fluid drains into container, and then quickly tighten screw.
 - 8) Repeat steps 6) and 7) above until there are no air bubbles in drained brake fluid and new fluid flows through vinyl tube.

NOTE:

- Add brake fluid as necessary while performing the air bleed operation, in order to prevent the tank from running short of brake fluid.
- 9) After completing the bleeding operation, hold brake pedal depressed and tighten screw and install bleeder cap.

Tightening torque:
8 N·m (0.8 kgf·m, 5.8 ft·lb)

- 10) Bleed air from each wheel cylinder by following the previous 5 steps.
- 11) Depress brake pedal with a force of approximately 294 N (30 kgf, 66 lb) and hold it there for approximately 20 seconds. At this time check pedal to see if it makes any unusual movement. Visually inspect bleeder screws and brake pipe joints to make sure that there is no fluid leakage.
- 12) Install wheels, and drive vehicle for a short distance between 2 to 3 km (1 to 2 miles) to make sure that brakes are operating properly.

DISC BRAKE PADS AND DISCS

PERIODIC MAINTENANCE SERVICES

19. Disc Brake Pads and Discs

A: INSPECTION

1. DISC BRAKE PAD AND DISC

- 1) Jack up vehicle and support with rigid racks. Then remove wheels.
- 2) Visually check pad thickness through inspection hole of disc brake assembly. Replace pad if necessary.

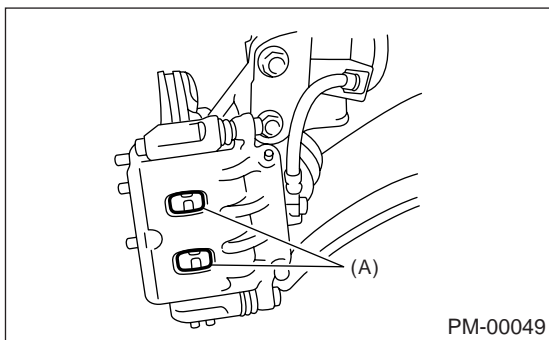

(A) Inspection hole

- 4) Measure the disc rotor runout at a point less than 10 mm (0.39 in) from the outer periphery of the rotor.

Disc rotor runout limit:

Front: 0.075 mm (0.0030 in)

Rear: 0.070 mm (0.0028 in)

NOTE:

When replacing a pad, always replace the pads for both the left and right wheels at the same time. Also replace pad clips if they are twisted or worn.

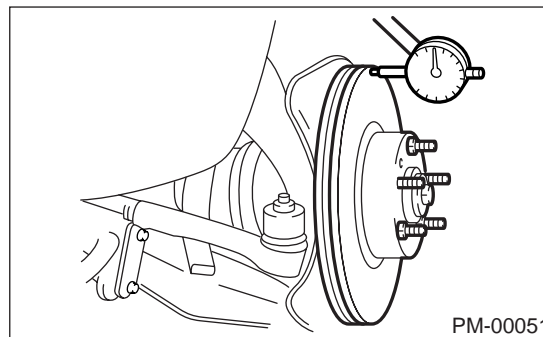

| Pad thickness mm (in) | | |
|-----------------------|-------------|-------------|
| | Front | Rear |
| Standard | 11 (0.43) | 9 (0.35) |
| Service limit | 1.5 (0.059) | 1.5 (0.059) |

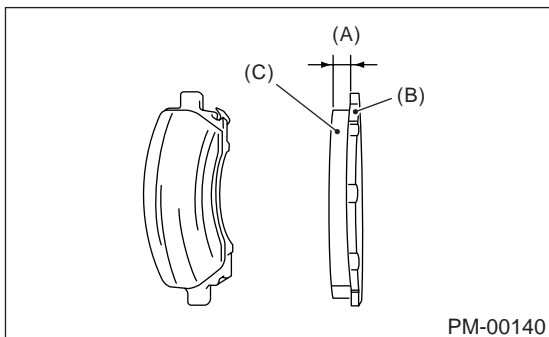

- (A) Thickness of pad
- (B) Back metal
- (C) Lining

- 3) Check the disc rotor, and correct or replace if it is damaged or worn.

| Brake disc thickness mm (in) | | |
|------------------------------|-----------|-------------|
| | Front | Rear |
| Standard | 24 (0.94) | 10 (0.39) |
| Wear limit | 22 (0.87) | 8.5 (0.335) |

20. Parking Brake

A: INSPECTION

Inspect brake linings and drums of both sides of the rear brake at the same time by removing brake drums.

1) Inspect brake shoes for damage or deformation and check brake linings for wear.

NOTE:

Always replace both primary and secondary brake shoes for the left and right wheels at the same time.

Brake lining thickness excluding back metal

Standard value: 3.2 mm (0.126 in)

Wear limit: 1.5 mm (0.059 in)

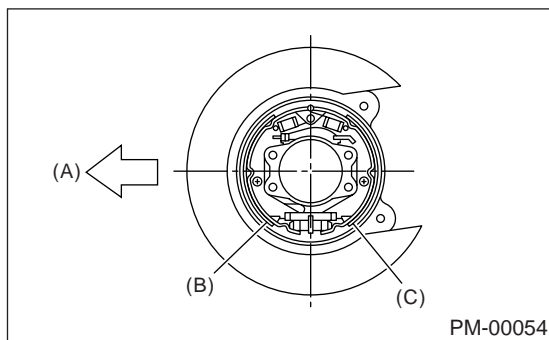

- (A) Front
- (B) Brake shoe (Primary)
- (C) Brake shoe (Secondary)

2) Check brake drum for wear, dents or other damage. If the inside surface of brake drum is streaked, correct the surface with emery cloth (#200 or more). If it is unevenly worn, tapered, or the outside surface of brake drum is damaged, correct or replace it.

Brake drum inside diameter

Standard value: 170 mm (6.69 in)

Wear limit: 171 mm (6.73 in)

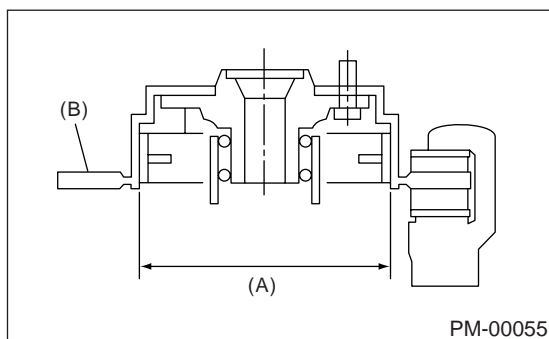

- (A) Measuring inside diameter
- (B) Disc

3) If the deformation or wear of back plate, shoe, etc. is noticeable, replace them.

4) When the shoe return spring tension is excessively weakened, replace it, taking care to identify upper and lower springs.

PARKING BRAKE

PERIODIC MAINTENANCE SERVICES

B: ADJUSTMENT

1. SHOE CLEARANCE

- 1) Remove adjusting hole cover from back plate.
- 2) Turn adjusting screw using a slot-type screwdriver until brake shoe is in close contact with disc rotor.

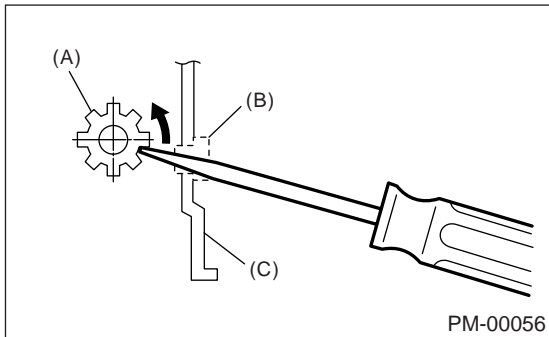

- (A) Adjusting screw
- (B) Cover (rubber)
- (C) Back plate

- 3) Turn back (downward) adjusting screw 3 or 4 notches.
- 4) Install adjusting hole cover to back plate.

2. LEVER STROKE

- 1) Remove console box lid.
- 2) Forcibly pull parking brake lever 3 to 5 times.
- 3) Adjust parking brake lever by turning adjuster until parking brake lever stroke is set at 6 notches with operating force of 196 N (20 kgf, 44 lb).

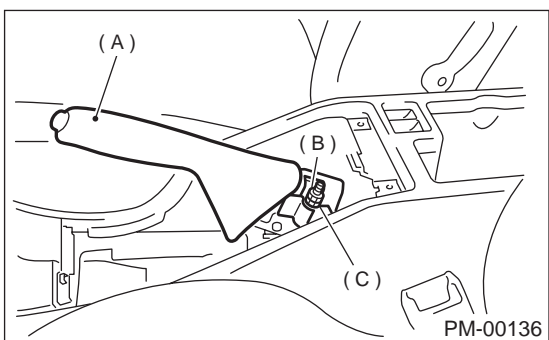

- (A) Parking brake lever
- (B) Lock nut
- (C) Adjusting nut

- 4) Tighten lock nut.
- 5) Install console box lid.

Lever stroke:

7 to 8 notches when pulled with a force of 196 N (20 kgf, 44 lb)

Tightening torque (Adjuster lock nut):

5.9 N·m (0.60 kgf·m, 4.3 ft-lb)

SUSPENSION

PERIODIC MAINTENANCE SERVICES

21. Suspension

A: INSPECTION

1. SUSPENSION BALL JOINT

- 1) Jack up vehicle until front wheels are off ground.
- 2) Next, grasp bottom of tire and move it in and out. If relative movement is observed between brake disc cover and end of transverse link, ball joint may be excessively worn.
- 3) Next, grasp end of transverse link and move it up and down. Relative movement between housing and transverse link boss indicates ball joint may be excessively worn.
- 4) If relative movement is observed in the immediately preceding two steps, remove and inspect ball joint. If free play exceeds standard, replace ball joint. <Ref. to FS-18, Front Ball Joint.>

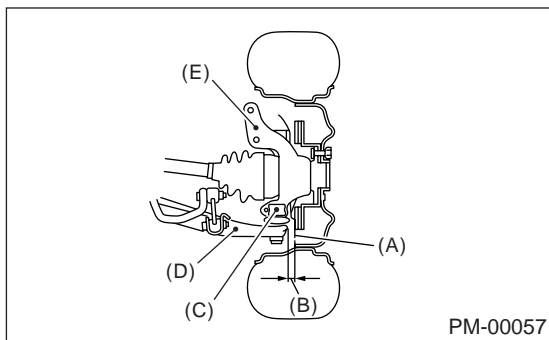

- (A) Disc cover
- (B) Relative movement
- (C) Ball joint
- (D) Transverse link
- (E) Housing

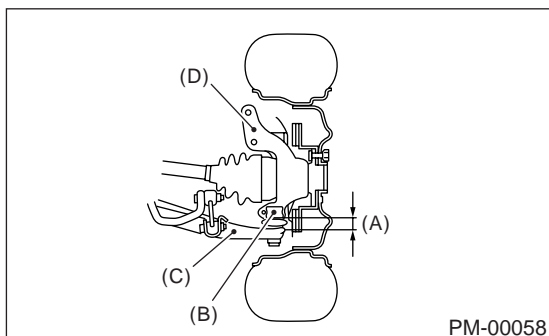

- (A) Relative movement
- (B) Ball joint
- (C) Transverse link
- (D) Housing

5) Damage of dust seal

Visually inspect ball joint dust seal. If it is damaged, remove transverse link. <Ref. to FS-15, Front Transverse Link.> And measure free play of ball joint. <Ref. to FS-18, Front Ball Joint.>

- (1) When looseness exceeds standard value, replace ball joint.
- (2) If the dust seal is damaged, replace with the new ball joint.

NOTE:

When transverse link ball joint has been removed or replaced, check toe-in of front wheel. If front wheel toe-in is not at specified value, adjust toe-in. <Ref. to FS-6, Wheel Alignment.>

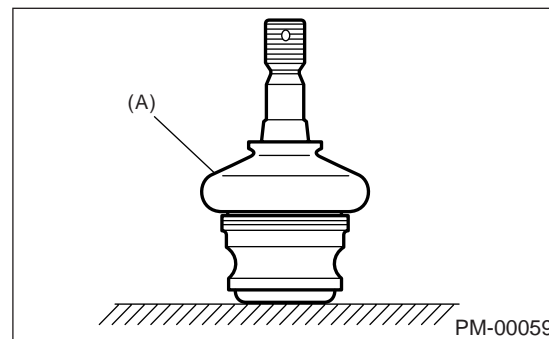

- (A) Dust seal

2. TRANSVERSE LINK'S REAR BUSHING

Check oil leaks at around liquid-filled bushing. If oil leaks, replace bushing.

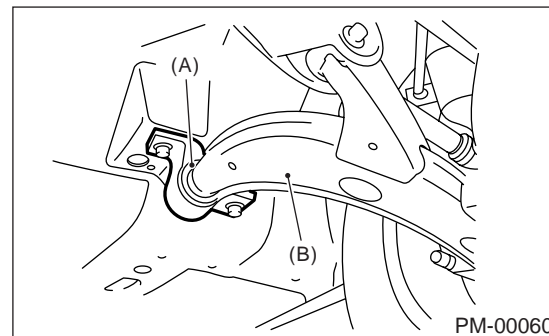

- (A) Rear bushing
- (B) Transverse link

SUSPENSION

PERIODIC MAINTENANCE SERVICES

3. WHEEL ARCH HEIGHT

- 1) Unload cargoes and set vehicle in curb weight (empty) condition.
- 2) Then, check wheel arch height of front and rear suspensions to ensure that they are within specified values.
- 3) When wheel arch height is out of standard, visually inspect following components and replace deformed parts.
 - Suspension components [Front strut assembly and rear shock absorber assembly]
 - Body parts to which suspensions are installed.
- 4) When no components are deformed, adjust wheel arch height by replacing coil spring in the suspension whose wheel arch height is out of standard. <Ref. to FS-6, Wheel Alignment.> <Ref. to RS-8, Wheel Alignment.>

4. WHEEL ALIGNMENT OF FRONT SUSPENSION

- 1) Check alignment of front suspension to ensure that following items conform to standard values.
 - Toe-in
 - Camber angle
 - Caster angle
 - Steering angle<Ref. to FS-6, Wheel Alignment.>
- 2) When caster angle does not conform to standard value, visually inspect following components and replace deformed parts.
 - Suspension components [Strut assembly, crossmember, transverse link, etc.]
 - Body parts to which suspensions are installed.
- 3) When toe-in and camber are out of standard value, adjust them so that they conform to respective service standard.
- 4) When right-and-left turning angles of tire are out of standard, adjust to standard value.

5. WHEEL ALIGNMENT OF REAR SUSPENSION

- 1) Check alignment of rear suspension to ensure that following items are within standard values.
 - Toe-in
 - Camber angle
 - Thrust angle<Ref. to RS-8, Wheel Alignment.>
- 2) When camber angle does not conform to standard value, visually inspect parts listed below. If deformation is observed, replace damaged parts.
 - Suspension components [Shock absorber, link F, link R, link UPR, arm R, sub frame, etc.]
 - Body parts to which suspensions are installed.
- 3) When toe-in and thrust angle are out of standard value, adjust them so that they conform to respective service standard.

6. OIL LEAKAGE OF STRUT AND SHOCK ABSORBER

Visually inspect front strut and rear shock absorber for oil leakage as instructed. Replace front strut and rear shock absorber if oil leaks excessively.

7. TIGHTNESS OF BOLTS AND NUTS

Check bolts and nuts shown in the figure for looseness. Retighten bolts and nuts to specified torque. If self-lock nuts and bolts are removed, replace them with new ones.

Front suspension: <Ref. to FS-3, COMPONENT, General Description.>

Rear suspension: <Ref. to RS-3, COMPONENT, General Description.>

8. DAMAGE TO SUSPENSION PARTS

- 1) Check the following parts and the fastening portion of the vehicle body for deformation or excessive rusting which impairs the suspension. If necessary, replace damaged parts with new ones. If minor rust formation, pitting, etc. are noted, remove rust and apply remedial anti-corrosion measures.
 - Front suspension
 - Transverse link
 - Crossmember
 - Strut
 - Rear suspension
 - Sub frame
 - Link F
 - Link R
 - Link UPR
 - Arm R
 - Shock absorber
 - In the district where salt is sprayed to melt snow on a road in winter, check suspension parts for damage caused by rust every 12 months after lapse of 60 months. Take rust prevention measure as required.

WHEEL BEARING

PERIODIC MAINTENANCE SERVICES

22. Wheel Bearing

A: INSPECTION

1. FRONT WHEEL BEARING

NOTE:

Inspect the condition of front wheel bearing grease.

- 1) Jack up the front of vehicle.
- 2) While holding front wheel by hand, swing it in and out to check bearing free play.
- 3) Loosen wheel nuts and remove front wheel.
- 4) If bearing free play exists in step 2) above, attach a dial gauge to hub and measure axial displacement in axial direction.

Service limit:

Straight-ahead position within 0.05 mm (0.0020 in)

- 5) Remove bolts and self-locking nuts, and extract transverse link from front crossmember.
 - 6) While lightly hammering spring pin which secures SFJ to transmission spindle, remove it.
 - 7) Extract SFJ from transmission spindle. <Ref. to DS-17, Front Axle.>
 - 8) While supporting front drive shaft horizontally with one hand, turn hub with the other to check for noise or binding.
- If hub is noisy or binds, disassemble front axle and check condition of oil seals, bearing, etc.

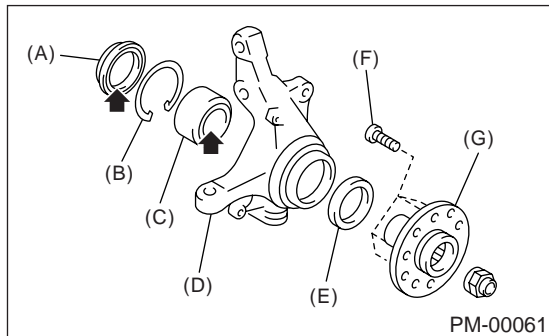

- (A) Inner oil seal
- (B) Snap ring
- (C) Bearing
- (D) Housing
- (E) Outer oil seal
- (F) Hub bolt
- (G) Hub

2. REAR WHEEL BEARING

- 1) Jack up the rear of vehicle.
- 2) While holding rear wheel by hand, swing it in and out to check bearing free play.
- 3) Loosen wheel nuts and remove rear wheel.
- 4) If bearing free play exists in step 2) above, attach a dial gauge to hub assembly and measure axial displacement in axial direction.

Service limit:

Straight-ahead position within 0.05 mm (0.0020 in)

- 5) Remove the DOJ of rear drive shaft from rear differential. <Ref. to DS-34, Rear Drive Shaft.>
- 6) While supporting rear drive shaft horizontally with one hand, turn hub assembly with the other to check for noise or binding.

If hub assembly is noisy or binds, disassemble rear axle and check condition of oil seals, bearings, etc.

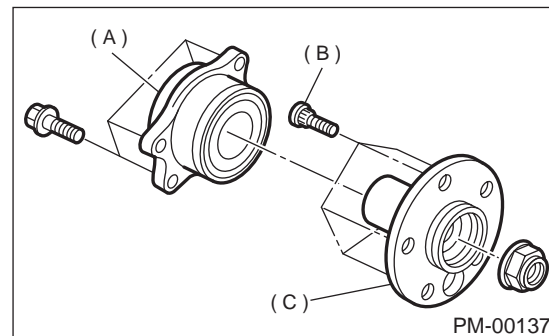

- (A) Hub unit
- (B) Hub bolt
- (C) Hub

AXLE BOOTS & JOINTS

PERIODIC MAINTENANCE SERVICES

23. Axle Boots & Joints

A: INSPECTION

1. FRONT AND REAR AXLE BOOTS

Inspect front axle boots (A) and rear axle boots (B) for deformation, damage or failure. If faulty, replace them with new ones. <Ref. to DS-28, Front Drive Shaft.> <Ref. to DS-34, Rear Drive Shaft.>

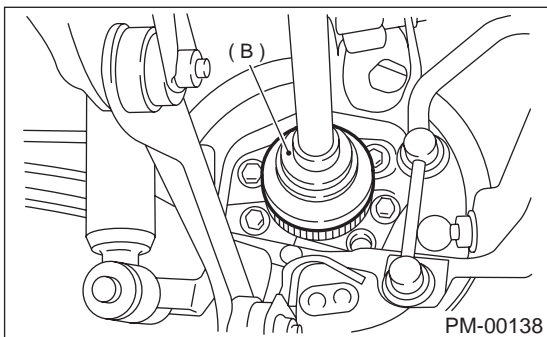
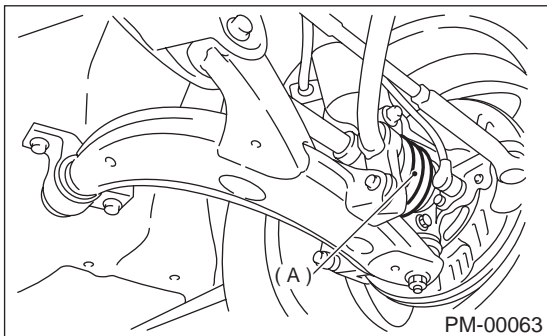

2. PROPELLER SHAFT

Inspect propeller shaft for damage or failure. If faulty, replace with a new one. <Ref. to DS-14, Propeller Shaft.>

24. Tire Rotation

A: INSPECTION

1) Replace the tire if the tread depth is less than 1.6 mm (0.063 in) or if wear indicators appear across the tire tread. (It is recommended that both right and left tires are replaced as a set.)

2) Adjust the wheel alignment if abnormally uneven tire wear is found.

3) Also, rotate the tires between the front and rear tires as illustrated, in order to ensure uniform tire wear.

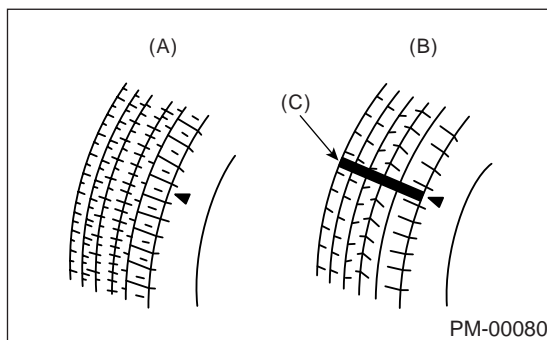
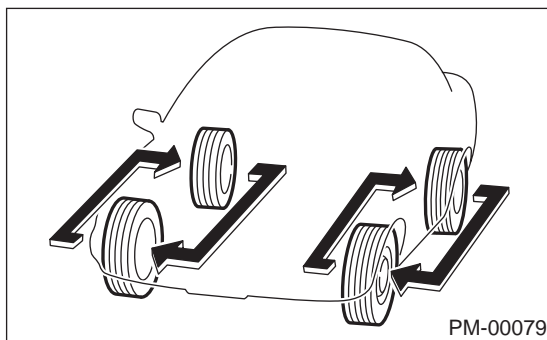

- (A) New tread
- (B) Worn tread
- (C) Tread wear indicator

STEERING SYSTEM (POWER STEERING)

PERIODIC MAINTENANCE SERVICES

25. Steering System (Power Steering)

A: INSPECTION

1. STEERING WHEEL

1) Set steering wheel in a straight-ahead position, and check wheel spokes to make sure they are correctly set in their specified positions.

2) Lightly turn steering wheel to the left and right to determine the point where front wheels start to move.

Measure the distance of the movement of steering wheel at the outer periphery of wheel.

Steering wheel free play:

0 — 17 mm (0 — 0.67 in)

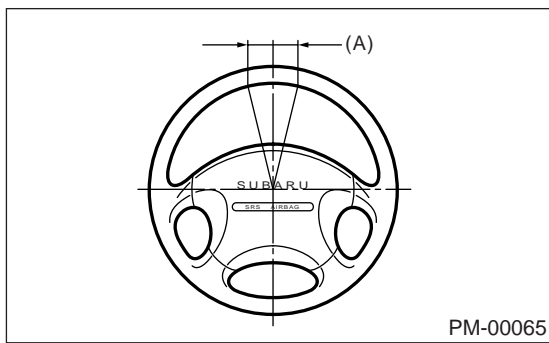

(A) Free play

Move steering wheel vertically toward the shaft to ascertain if there is play in the direction.

Maximum permissible play:

0.5 mm (0.020 in)

3) Drive vehicle and check the following items during operation.

(1) Steering force

The effort required for steering should be smooth and even at all points, and should not vary.

(2) Pull to one side

Steering wheel should not be pulled to either side while driving on a level surface.

(3) Wheel runout

Steering wheel should not show any sign of runout.

(4) Return factor

Steering wheel should return to its original position after it has been turned and then released.

2. STEERING SHAFT JOINT

1) When steering wheel free play is excessive, disconnect universal joint of steering shaft and check it for any play and yawing torque (at the point of the crossing direction). Also inspect for any damage to sealing or worn serrations. If the joint is loose, retighten the mounting bolts to the specified torque.

Tightening torque:

24 N·m (2.4 kgf-m, 17.4 ft-lb)

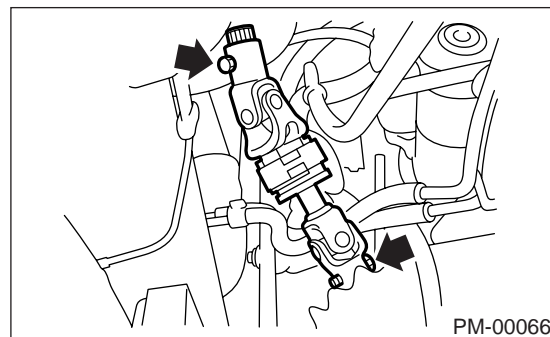

3. GEARBOX

1) With wheels placed on a level surface, turn steering wheel 90° in both the left and right directions.

While wheel is being rotated, reach under vehicle and check for looseness in gearbox.

Tightening torque:

59 N·m (6.0 kgf-m, 43.4 ft-lb)

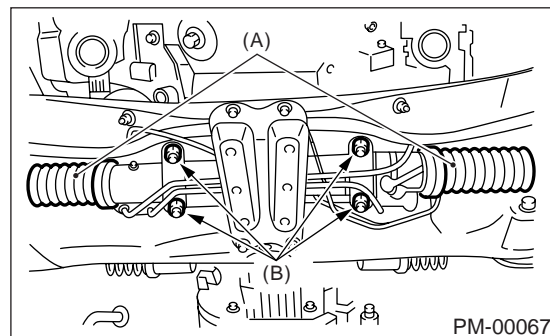

(A) Boot

(B) Gearbox mounting bolts

2) Check boot for damage, cracks or deterioration.
3) With vehicle on a level surface, quickly turn steering wheel to the left and right.

While steering wheel is being rotated, check the gear backlash. If any unusual noise is noticed, adjust the gear backlash in the following manner.

(1) Tighten adjusting screw to 7.4 N·m (0.75 kgf-m, 5.4 ft-lb) and then loosen. Repeat this operation twice.

(2) Retighten adjusting screw to 7.4 N·m (0.75 kgf-m, 5.4 ft-lb) and back off 25°.

STEERING SYSTEM (POWER STEERING)

PERIODIC MAINTENANCE SERVICES

- (3) Apply liquid packing to at least 1/3 of entire perimeter of adjusting screw thread.

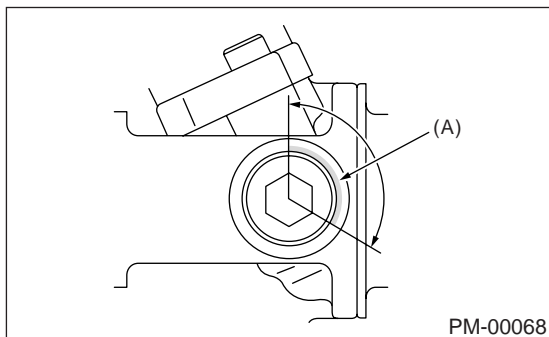

- (A) Apply liquid packing to at least 1/3 of entire perimeter.

- (4) Install lock nut. While holding adjusting screw with a wrench, tighten lock nut using ST 926230000 SPANNER

Tightening torque (Lock nut):
39 N·m (4.0 kgf·m, 29 ft·lb)

Hold the adjusting screw with a wrench to prevent it from turning while tightening the lock nut.

4. TIE-ROD

- 1) Check tie-rod and tie-rod ends for bends, scratches or other damage.

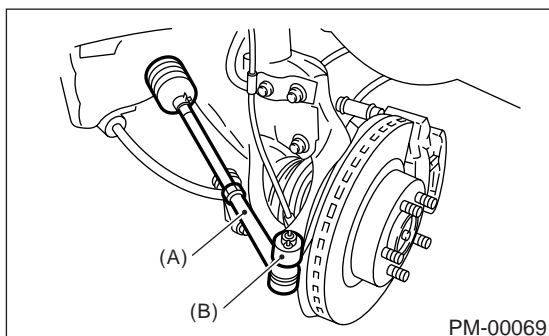

- (A) Tie-rod end
(B) Knuckle arm

- 2) Check connections of knuckle ball joints for play, inspect for damage on dust seals, and check free play of ball studs. If castle nut is loose, retighten it to the specified torque, then tighten further up to 60° until cotter pin hole is aligned.

Tightening torque:
27 N·m (2.75 kgf·m, 19.9 ft·lb)

- 3) Check lock nut on the tie-rod end for tightness. If it is loose, retighten it to the specified torque.

Tightening torque:
83 N·m (8.5 kgf·m, 61.5 ft·lb)

5. POWER STEERING FLUID LEVEL

NOTE:

The fluid level must be checked when the temperature of the reservoir tank surface is approximately 20°C (68°F).

- 1) Place vehicle with engine "off" on the flat and level surface.

- 2) Check the fluid level using the scale on the outside of the reservoir tank (A). If the level is below "MIN" (B), add fluid to bring it up to "MAX" (C).

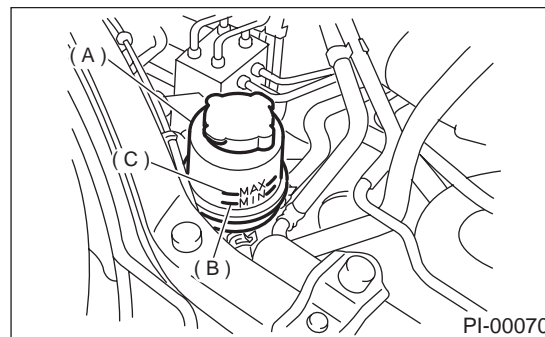

NOTE:

If fluid level is at MAX level or above, drain fluid to keep the level in the specified range of indicator by using a syringe or the like.

Recommended fluid:
Dexron III

Fluid capacity:
0.7 ℓ (0.7 US qt, 0.6 Imp qt)

6. POWER STEERING FLUID FOR LEAKS

Inspect the underside of oil pump and gearbox for power steering system, hoses, piping and their couplings for fluid leaks.

If fluid leaks are found, correct them by retightening their fitting bolts (or nuts) and/or replacing their parts.

NOTE:

- Wipe the leakage fluid off after correcting fluid leaks, or a wrong diagnosis is taken later.
- Also pay attention to clearances between hoses (or pipings) and other parts when inspecting fluid leaks.

STEERING SYSTEM (POWER STEERING)

PERIODIC MAINTENANCE SERVICES

7. HOSES OF OIL PUMP FOR DAMAGES

Check pressure hose and return hose of oil pump for crack, swell or damage. Replace hose with a new one if necessary.

NOTE:

Prevent hoses from revolving and/or turning when installing hoses.

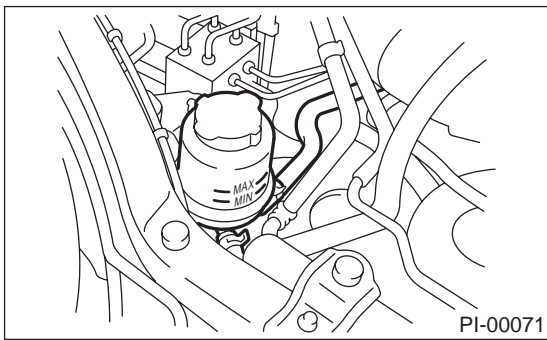

8. POWER STEERING PIPES FOR DAMAGE

Check power steering pipes for corrosion and damage.

Replace pipes with new ones if necessary.

9. GEARBOX BOOTS

Inspect both sides of gearbox boots as follows, and correct the defects if necessary.

- 1) (A) and (B) positions of gearbox boot are fitted correspondingly in (A) and (B) grooves of gearbox and the rod.
- 2) Clips are fitted outside of (A) and (B) positions of boot.
- 3) Boot does not have crack and hole.

NOTE:

Rotate (B) position of gearbox boot against twist of it produced by adjustment of toe-in, etc. Apply grease to the groove (C).

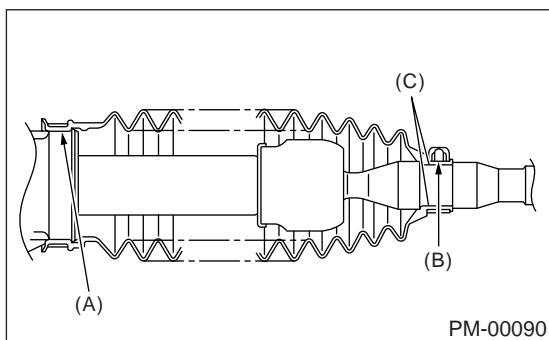

10. FITTING BOLTS AND NUTS

Inspect fitting bolts and nuts of oil pump and bracket for looseness, and retighten them if necessary. Inspect and/or retighten them when engine is cold.

SUPPLEMENTAL RESTRAINT SYSTEM

PERIODIC MAINTENANCE SERVICES

26. Supplemental Restraint System

A: INSPECTION

Check the airbag system in accordance with the result of the self-diagnosis. <Ref. to AB-2, Basic Diagnostic Procedure.>

1) Ensure that airbag connectors are connected. If not, properly connect. When the ignition switch is turned ON with the connector(s) disconnected, the airbag warning light blinks to identify the fault.

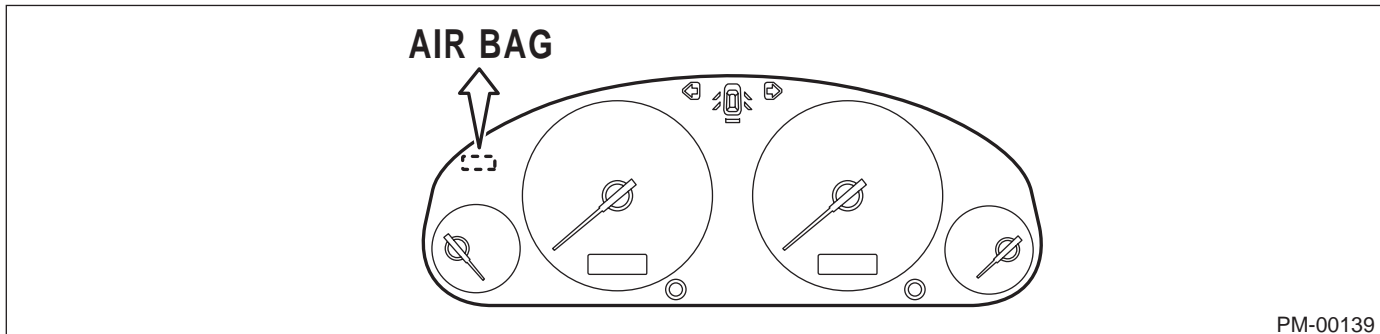

2) Turn the ignition switch ON, and connect the airbag diagnosis terminal of the service connector (located below lower cover) to the ground terminal.

3) The warning light blinks to indicate a trouble code (a fault is identified). When the airbag system is in good order (no trouble codes are stored in the memory), the warning light blinks on and off at 0.6 second intervals (as long as the diagnosis terminal is connected to the ground terminal).

4) When the warning light indicates a trouble code, check the airbag system in accordance with the troubleshooting procedure. <Ref. to AB-2, Basic Diagnostic Procedure.>

SUPPLEMENTAL RESTRAINT SYSTEM

PERIODIC MAINTENANCE SERVICES

MEMO:

PM-42