

# ENGINE OIL

## PERIODIC MAINTENANCE SERVICES

### 3. Engine Oil

#### A: REPLACEMENT

**NOTE:**

Replace engine oil and engine oil filter at the same time.

1) Drain engine oil by loosening engine oil drain plug.

#### 2.5 L model

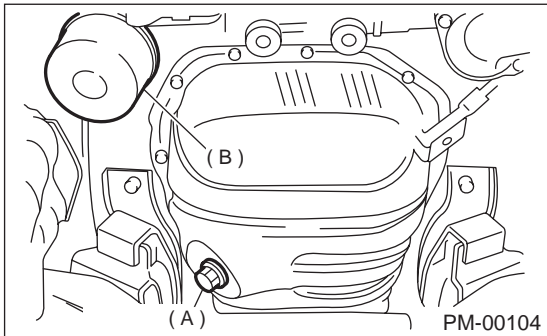

- (A) Drain plug
- (B) Oil filter

#### 3.0 L model

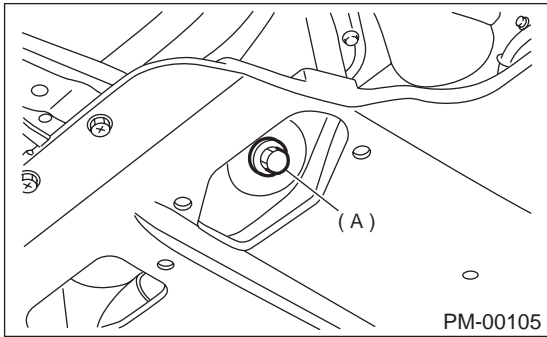

- (A) Drain plug

2) Open engine oil filler cap for quick draining of the engine oil.

#### 2.5 L model

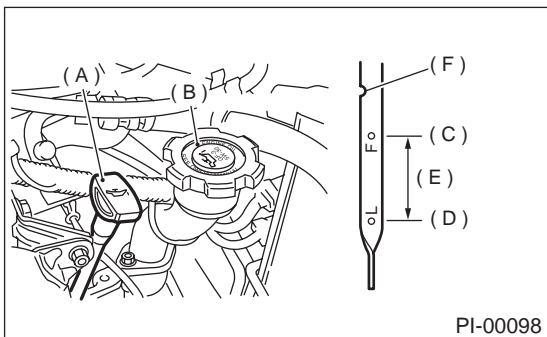

#### 3.0 L model

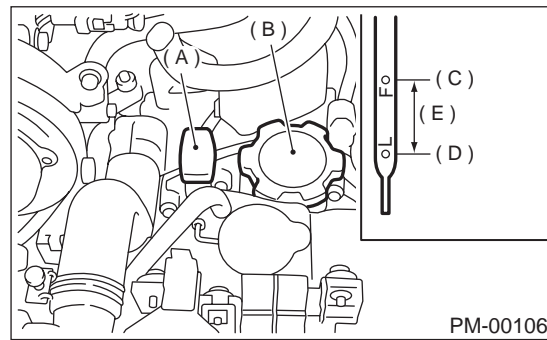

- (A) Oil level gauge
- (B) Engine oil filler cap
- (C) Upper level
- (D) Lower level
- (E) About 1.0 ℓ (1.1 US qt, 0.9 imp qt)
- (F) Notch

3) Replace drain plug gasket.

4) Tighten engine oil drain plug after draining engine oil.

**Tightening torque:**

**44 N·m (4.5 kgf·m, 33 ft·lb)**

5) Fill engine oil through filler pipe up to upper point on level gauge. Make sure that vehicle is placed level when checking oil level. Use engine oil of proper quality and viscosity, selected in accordance with the table in figure.

**Engine oil amount for preparation:**

**2.5 L model**

**Approx. 4.0 ℓ (4.2 US qt, 3.5 Imp qt)**

**3.0 L model**

**Approx. 5.6 ℓ (5.9 US qt, 4.9 Imp qt)**

SAE Viscosity No. and Applicable Temperature							
(°C)	-30	-20	-15	0	15	30	40
(°F)	-22	-4	5	32	59	86	104
	10W-30, 10W-40						
	5W-30 PREFERRED						

PM-00107

## ENGINE OIL

### PERIODIC MAINTENANCE SERVICES

The proper viscosity helps vehicle get good cold and hot starting by reducing viscous friction and thus increasing cranking speed.

#### NOTE:

- When replenishing oil, it does not matter if the oil to be added is a different brand from that in the engine; however, use oil having the ILSAC or API classification, and SAE viscosity No. designated by SUBARU.

- If vehicle is used in desert areas with very high temperatures or for other heavy duty applications, the following viscosity oils may be used:

API classification: SL

ILSAC classification: GF-3

SAE Viscosity No.: 30, 40, 10W-50, 20W-40, 20W-50

6) Close engine oil filler cap.

7) Start engine and warm it up for a time.

8) After engine stops, recheck the oil level.

If necessary, add engine oil up to upper level on level gauge.

#### 2.5 L model

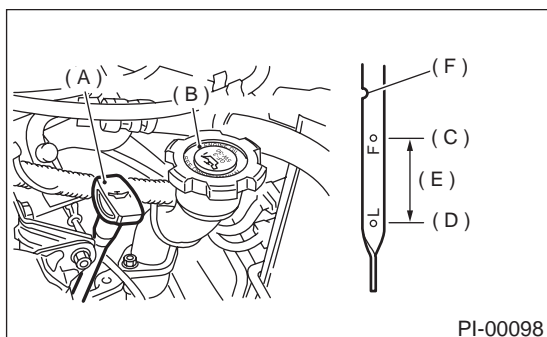

PI-00098

#### 3.0 L model

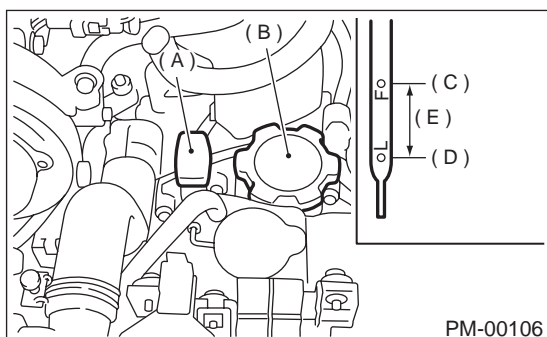

PM-00106

- (A) Oil level gauge
- (B) Engine oil filler cap
- (C) Upper level
- (D) Lower level
- (E) About 1.0 ℓ (1.1 US qt, 0.9 imp qt)
- (F) Notch mark

#### B: INSPECTION

- 1) Park vehicle on a level surface.
- 2) Remove oil level gauge and wipe it clean.
- 3) Reinsert the level gauge all the way. Be sure that the level gauge is correctly inserted and in the proper orientation.
- 4) Remove it again and note the reading. If the engine oil level is below the "L" line, add oil to bring the level up to the "F" line.
- 5) After turning off the engine, wait a few minutes for the oil to drain back into the oil pan before checking the level.
- 6) Just after driving or while the engine is warm, engine oil level may show in the range between the "F" line and the notch mark. This is caused by thermal expansion of the engine oil.
- 7) To prevent overfilling the engine oil, do not add oil above the "F" line when the engine is cold.