

BRAKE LINE

PERIODIC MAINTENANCE SERVICES

17.Brake Line

A: INSPECTION

1. BRAKE LINE

1) Check scratches, swelling, corrosion and/or traces of fluid leakage on brake hoses or pipe joints.

2) Check the possibility of adjacent parts interfering with brake pipes/hoses during driving, and loose connections/clamps.

3) Check any trace of fluid leakage, scratches, etc. on master cylinder, wheel cylinder and pressure control valve.

NOTE:

- When the brake fluid level in the reservoir tank is lower than the specified limit, the brake fluid warning light on the combination meter will come on.
- Visually check brake hose (using a mirror where it is difficult to see) for any damage.

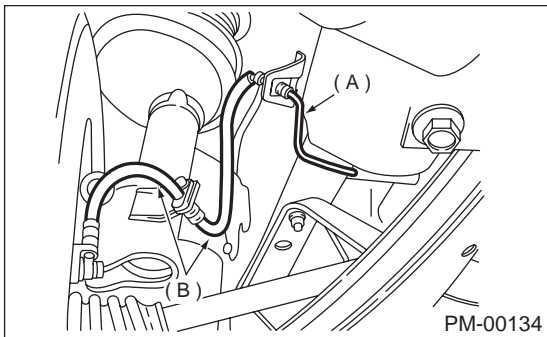

- (A) Front brake pipe
- (B) Front brake hose

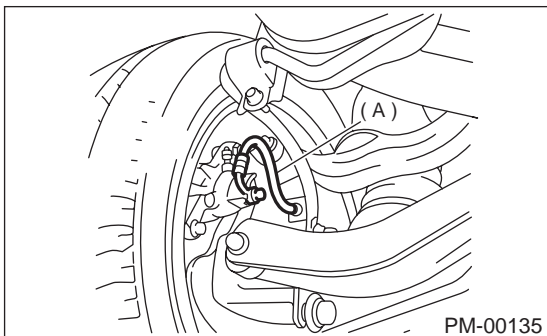

- (A) Rear brake hose

B: CHECKING

1. SERVICE BRAKE

1) Check the free play of brake pedal with a force of less than 10 N (1 kgf, 2 lb).

Brake pedal free play:

1 — 3 mm (0.04 — 0.12 in)

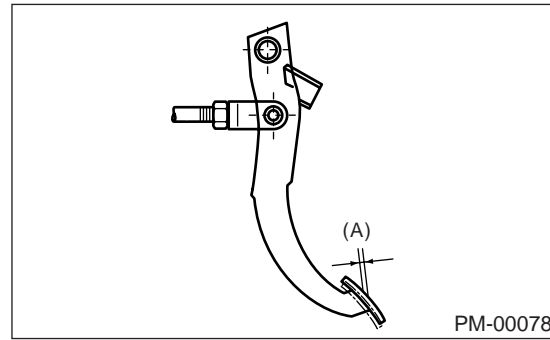

- (A) Pedal play

2) If the free play is out of specifications above, adjust the brake pedal as follows:

- (1) Be sure engine is off. (No vacuum is applied to brake booster.)
- (2) There should be play between brake booster clevis and pin at brake pedal installing portion.

[Depress brake pedal pad with a force of less than 10 N (1 kgf, 2 lb) to a stroke of 1 to 3 mm (0.04 to 0.12 in).]

- (3) Depress the surface of brake pad by hand.

BRAKE LINE

PERIODIC MAINTENANCE SERVICES

(4) If there is no free play between clevis pin and clevis, turn brake switch adjusting nut until the clearance between stopper and screw of brake switch becomes 0.3 mm (0.012 in).

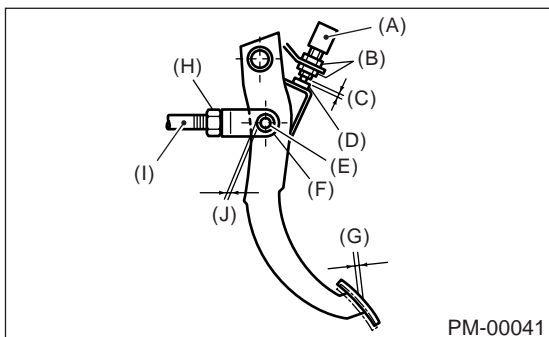

- (A) Brake switch
- (B) Adjusting nut
- (C) 0.3 mm (0.012 in)
- (D) Stopper
- (E) Clevis pin
- (F) Clevis
- (G) Pedal play
1 - 3 mm (0.04 - 0.12 in)
- (H) Lock nut
- (I) Brake booster operating nut
- (J) Play at pin

3) Check the pedal stroke.

While the engine is idling, depress the brake pedal with a 490 N (50 kgf, 110 lb) load and measure the distance between the brake pedal and steering wheel. With the brake pedal released, measure the distance between the pedal and steering wheel again. The difference between the two measurements must be less than 95 mm (3.74 in). If the distance is more than specified, there is a possibility air is in the inside of the hydraulic unit.

Brake pedal reserve distance: A
more than 95 mm (3.74 in)/ 490 N (50 kgf, 110 lb)

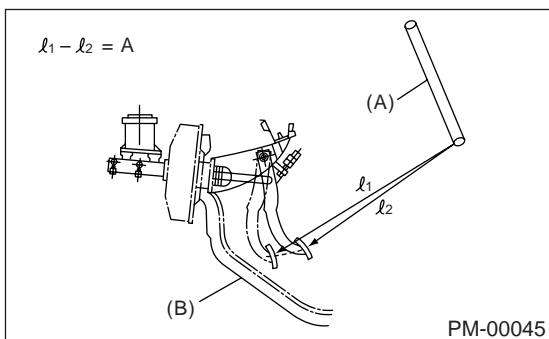

- (A) Steering wheel
- (B) Toe board

4) Check to see if air is in the hydraulic brake line by the feel of pedal operation. If air appears to exist in the line, bleed it from the system.

5) Check for even operation of all brakes, using a brake tester or by driving the vehicle for a short distance on a straight road.

2. BRAKE SERVO SYSTEM

1) With the engine off, depress the brake pedal several times applying the same pedal force: Make sure the travel distance should not change.

2) With the brake pedal depressed, start the engine: Make sure the pedal should move slightly toward the floor.

3) With the brake pedal depressed, stop the engine and keep the pedal depressed for 30 seconds: Make sure the pedal height should not change.

4) Check valve is built into vacuum hose. Disconnect vacuum hose to inspect function of check valve.

Blow air into vacuum hose from its brake booster side end: Air must flow out of engine side end of hose. Next blow air into hose from engine side: Air should not flow out of hose.

Replace both check valve and vacuum hose if check valve is faulty. Engine side of vacuum hose is indicated by marking "ENGINE" as shown.

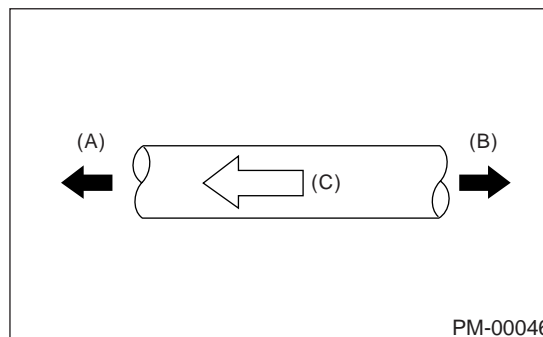

- (A) Engine side
- (B) Brake booster side
- (C) ENG

5) Check vacuum hose for cracks or other damage.

NOTE:

When installing the vacuum hose on the engine and brake booster, do not use soapy water or lubricating oil on their connections.

6) Check vacuum hose to make sure it is tight and secure.