

20. Parking Brake

A: INSPECTION

Inspect brake linings and drums of both sides of the rear brake at the same time by removing brake drums.

1) Inspect brake shoes for damage or deformation and check brake linings for wear.

NOTE:

Always replace both primary and secondary brake shoes for the left and right wheels at the same time.

Brake lining thickness excluding back metal

Standard value: 3.2 mm (0.126 in)

Wear limit: 1.5 mm (0.059 in)

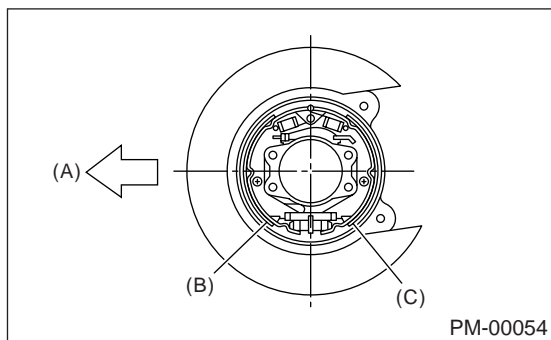

- (A) Front
- (B) Brake shoe (Primary)
- (C) Brake shoe (Secondary)

2) Check brake drum for wear, dents or other damage. If the inside surface of brake drum is streaked, correct the surface with emery cloth (#200 or more). If it is unevenly worn, tapered, or the outside surface of brake drum is damaged, correct or replace it.

Brake drum inside diameter

Standard value: 170 mm (6.69 in)

Wear limit: 171 mm (6.73 in)

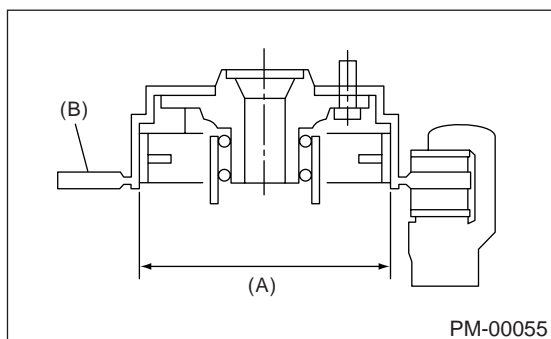

- (A) Measuring inside diameter
- (B) Disc

3) If the deformation or wear of back plate, shoe, etc. is noticeable, replace them.

4) When the shoe return spring tension is excessively weakened, replace it, taking care to identify upper and lower springs.

PARKING BRAKE

PERIODIC MAINTENANCE SERVICES

B: ADJUSTMENT

1. SHOE CLEARANCE

- 1) Remove adjusting hole cover from back plate.
- 2) Turn adjusting screw using a slot-type screwdriver until brake shoe is in close contact with disc rotor.

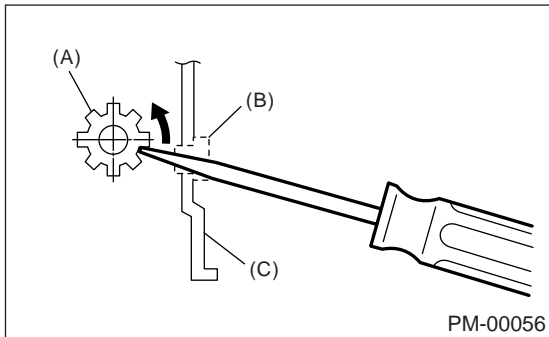

- (A) Adjusting screw
- (B) Cover (rubber)
- (C) Back plate

- 3) Turn back (downward) adjusting screw 3 or 4 notches.
- 4) Install adjusting hole cover to back plate.

2. LEVER STROKE

- 1) Remove console box lid.
- 2) Forcibly pull parking brake lever 3 to 5 times.
- 3) Adjust parking brake lever by turning adjuster until parking brake lever stroke is set at 6 notches with operating force of 196 N (20 kgf, 44 lb).

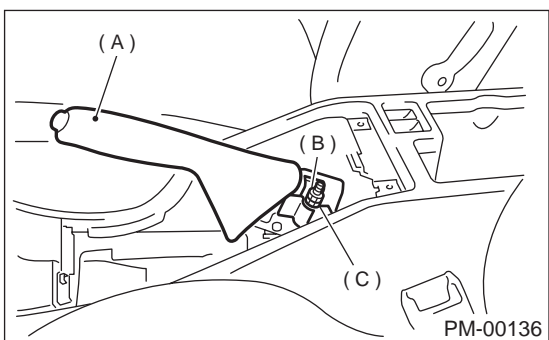

- (A) Parking brake lever
- (B) Lock nut
- (C) Adjusting nut

- 4) Tighten lock nut.
- 5) Install console box lid.

Lever stroke:

7 to 8 notches when pulled with a force of 196 N (20 kgf, 44 lb)

Tightening torque (Adjuster lock nut):

5.9 N·m (0.60 kgf·m, 4.3 ft-lb)